

K-SERIES

944K WHEEL LOADER



JOHN DEERE



**A HYBRID OF EPIC
INNOVATIONS**

PRODUCTION-C BULLY

MOVE MORE WITH THE 944K.



CLASS



RELIABLE



PRODUCTIVE



***WE DIDN'T BECOME ONE OF
THE LEADING MANUFACTURERS
OF PRODUCTION-CLASS LOADERS
BY FOLLOWING THE PACK.***

Backed by over 45 years of experience producing wheel loaders. Inspired by invaluable input from the brightest minds in the industry, our Customer Advocate Group. Our largest wheel loader, the new 944K offers an alternative for quarry and aggregate applications that redefines your expectations about a loader in this class. Featuring a hybrid-electric drive system designed to increase engine life and reduce fuel consumption, it combines the exceptional productivity you've come to expect from Deere production-class loaders with unprecedented reliability and efficiency. **Let the revolution begin.**

KING OF THE LOAD.

SERIOUS PRODUCTIVITY, MAXIMUM EFFICIENCY

Handling shot rock just got a shot in the arm at your quarry. The hybrid-electric 944K helps maximize productivity and efficiency at a lower daily operating cost.

Long-term reliability

Hybrid-electric drive system is designed to be more dependable. Brushless A/C generators and motors, water-cooled brake resistors, and solid-state power electronics deliver reliable, long-term performance. Reduced engine-speed range increases wear life over conventional drives.

Fuel-efficient IT4 engine

PowerTech™ EPA Interim Tier 4 (IT4)/EU Stage IIIB engine coupled with a hybrid-electric drive delivers up to 40-percent fuel savings compared to the conventional drivetrains on competitors' models.*

Improved hydraulic and oil plumbing

Hoses in the articulation area are routed using a unique ribbon system designed to eliminate rubbing and wear in difficult-to-reach areas.

Highly efficient Quad-Cool™

Quad-Cool design places coolers in a boxed configuration that's isolated from engine heat, for increased efficiency and durability. No other cooling system can come close to Quad-Cool's resistance to plugging and ease of cleaning.



BURNS 40% LESS FUEL
THAN CONVENTIONAL DRIVETRAINS*



**Actual fuel consumption rates and savings will vary with machine application, utilization, operator, and model of competitive unit.*

STANDOUT FEATURE

*A PERFECT HYBRID OF
EFFICIENCY AND PRODUCTIVITY.*

HYBRID- ELECTRIC DRIVE SYSTEM

POWER AND CONTROL.

MASS PRODUCTION

Everyone knows hybrid-electric drives burn less fuel. But they're highly productive, too, delivering quick, smooth, and responsive hydraulics; fast ramp-climbing capability; and strong pushing power. Plus control of automatic traction and rimpull helps eliminate wheel spin and tire wear, further reducing daily operating costs.

Traction control

Standard traction control automatically limits torque to any wheel when slippage occurs, increasing machine traction in poor underfoot conditions. Eliminating runaway wheel spin increases tire life, while reducing operating costs.

Rimpull control

Rimpull control limits torque on the wheels in slick working conditions, preventing tire spin and slicing. Four settings can be incrementally selected through the sealed-switch module to optimize traction when crowding against a load.

Fuel efficient

Hybrid-electric drive recaptures energy while slowing the loader when the operator lets off the accelerator. This lessens the load on the engine, further reducing fuel consumption.

Three operator-selected rpms

Engine runs at a choice of three constant operator-selected rpms, so boom and bucket functions are powerful, responsive, and quick, while optimum fuel efficiency is maintained. Reduces overall machine noise and operator fatigue.

Coast control reduces service-brake wear

Coast-control feature functions like dynamic braking in a hydrostatic transmission, slowing the loader without touching a pedal and helping reduce service-brake component wear.

Low noise

At only 108 dBA, noise is much less noticeable to bystanders than with other loaders, making this loader a good neighbor. For the operator, cab noise is only 72 dBA.

Powerful and quick

Strong pushing power and quick ramp-climbing ability make the 944K Hybrid an excellent choice for maintaining stockpiles and heaping hoppers in quarry operations and other production facilities.



**OPTIMIZED
TRACTION**
WITH RIMPULL CONTROL

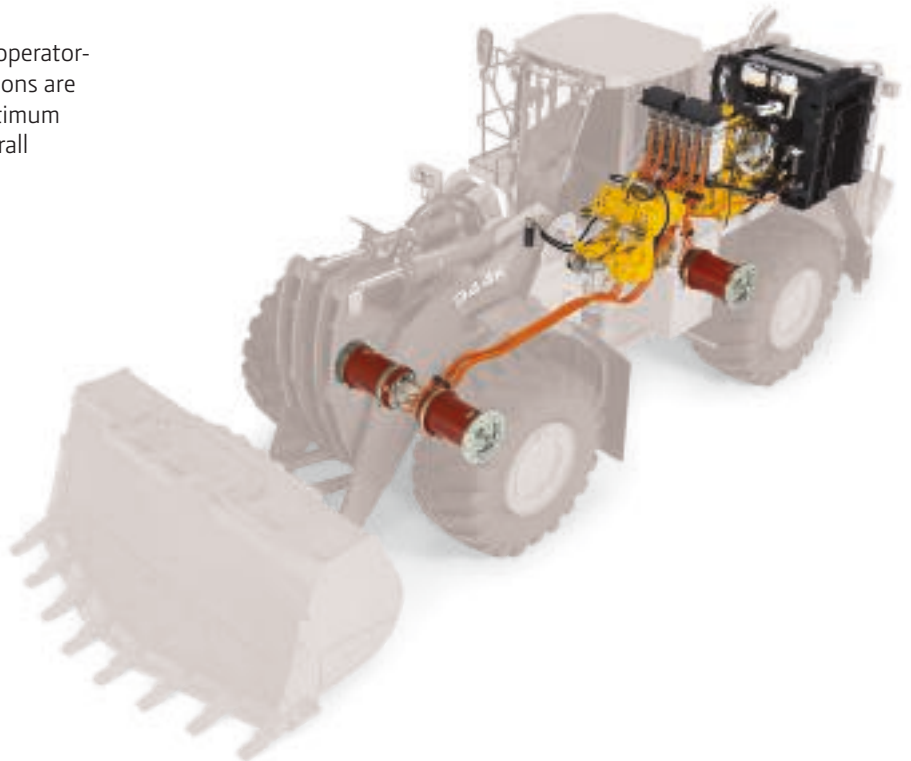



LOAD WARRIOR

***GET MORE DONE FROM THE
COMFORT OF YOUR CAB.***

Our largest loader boasts the biggest cab, quickest boom-raise time, and fastest cycle times in its class. Outstanding visibility with LED lighting options combined with smooth, responsive hydraulics help you work harder with less effort.



**10-IN.-WIDER CAB
THAN THE 844K-II**



Large, spacious cab

Quieter, more spacious cab is 10-in. wider than the 844K-II, making it the largest in its class. Cooler compartment and beverage holder ensure plenty of room to stow your stuff. Floor-to-ceiling front glass provides a commanding view to the bucket and tires.

Smooth, responsive hydraulics

Flow-sharing hydraulic system boasts the fastest cycle times and the quickest boom-raise time in the 944K's size class, speeding short-pattern truck loading. Each boom and bucket function has its own hydraulic pump for quick, smooth operation, and faster truck loading.

Front fenders improve tire visibility

Front fender has been cut back to enable greater visibility to the front tire, so the operator can see when slippage occurs. Fender extensions are available.

Standard joystick steering

Joystick steering adapts to ground speed to deliver smooth, low-effort control for fatigue-beating comfort. F-N-R switch with up- and downshift buttons ensures fast, smooth shifting and directional changes. Having no steering wheel maximizes visibility to the front.

Light for life

Courtesy lighting illuminates entrance/exit in dark environments. Plus the premium LED lighting package enhances visibility in low- or no-light conditions. LED lights are extremely bright, for superior illumination, plus they rarely need to be changed, extending wear life.

Electrohydraulic boom and bucket controls

Electrohydraulic control of boom and bucket ensures smooth operation with less fatigue. Quick-shift button on the bucket joystick allows the operator to temporarily shift down or up at the touch of button. Backlit touchpad sealed-switch module allows setting of boom-height kickout, return to carry, and return to dig from the seat.

Dual-slab boom and cylinders provide a clear view

944K features traditional Z-Bar linkage with dual-slab boom and cylinders, providing unmatched visibility to the center of the spade-nose bucket when dumping rock into quarry trucks. Optional long boom adds 18 in. of pin height and an additional 8.5 in. of reach for loading 70-ton haul trucks.

SERVICE MADE SIMPLE

ELIMINATE DOWNTIME.

TK-Series Bucket Teeth

Available TK-Series Bucket Teeth are engineered to deliver maximum strength and impact absorption, for longer life. Hammerless changing ensures safer installation.

Ground-level fueling and daily service

All daily service points including fueling are grouped for quick and convenient ground-level access.

Accessible filter changes and drivetrain access

Filter bank and right-side service center are easily accessible, easing periodic maintenance and repairs.

Easy greasing

Greasing is less messy thanks to centralized lube banks that are grouped for quick and convenient access to zerks. Optional auto-lube system is hydraulically driven and integrated with machine diagnostics. The machine even honks when the reservoir is filled.

Simplified DPF service

Ash-service intervals for the diesel particulate filter (DPF) are condition based, so changing it may not be necessary until the first engine overhaul. Intervals can be extended further depending on application, regular maintenance practices, and the use of recommended fluids and lubricants.



Reduce operating costs with
ULTIMATE UPTIME

Ultimate Uptime, featuring John Deere WorkSight™, is a customizable support solution available exclusively from your Deere dealer. This flexible offering maximizes equipment availability with standard John Deere WorkSight capabilities that can help prevent future downtime and speed repairs when needed. In addition to the base John Deere WorkSight features, our dealers work with you to build an uptime package that meets the specific needs of your machine, fleet, project, and business, including customized maintenance and repair agreements, onsite parts availability, extended warranties, fluid sampling, response-time guarantees, and more.

Get valuable insight with
JOHN DEERE WORKSIGHT

John Deere WorkSight is an exclusive suite of telematic solutions that increases uptime while lowering operating costs. At its heart, JDLink™ Ultimate machine monitoring provides real-time utilization data and alerts to help you maximize productivity and efficiency while minimizing downtime. Remote diagnostics enable your dealer to read codes, record performance data, and even update software without a trip to the jobsite.





944K SPECIFICATIONS

Engine		944K STANDARD BOOM / LONG BOOM	
Manufacturer and Model	John Deere PowerTech™ PSX 6135		
Non-Road Emission Standard	EPA Interim Tier 4/EU Stage IIIB		
Cylinders	6		
Valves per Cylinder	4		
Displacement	13.5 L (824 cu. in.)		
Net Peak Power (ISO 9249)	400 kW (536 hp) at 1,600 rpm		
Net Peak Torque (ISO 9249)	2530 Nm (1,866 lb.-ft.) at 1,400 rpm		
Net Torque Rise	23%		
Fuel System (electronically controlled)	Mechanically actuated electronic unit injectors		
Lubrication	Full-flow spin-on filter and integral cooler		
Aspiration	Series turbocharged, charge air cooled		
Air Cleaner	Under-hood dual-element dry type; restriction indicator in cab monitor for service		
Cooling			
Fan Drive	Hydraulically driven, proportionally controlled, fan aft of coolers		
Electrical			
Electrical System	24 volt with 150-amp alternator		
Batteries (2 – 12 volt)	1,400 CCA (each) and optional cold-weather-battery option (12-volt, 1,400-CCA batteries [4 total])		
Reserve Capacity	440 min. (880 min. with cold-weather-battery option)		
Alternator Rating	150 amp		
Lights			
Halogen Package	Drive lights (2) with guard; brake and taillights; work lights: front cab (4), rear cab (2), rear machine (2), platform (2), engine compartment light (1), and LED turn signals and hazards		
LED Package	Same as halogen package except platform and engine compartment lights are halogen (all other lights are LED)		
Deluxe LED Package	Includes extra LED worklights (2) next to drive lights and extra front cab LED work lights (2)		
Standard	Turn signals and hazards		
Drive System			
Type	Hybrid-electric direct drive		
Generators (2)	Brushless A/C		
Motor Type	Brushless A/C wheel motors (4 – one for each wheel)		
Inverters	Solid-state power		
Operator Interface	Joystick-mounted F-N-R; quick-shift button on hydraulic boom-control lever		
Shift Modes	Auto mode (1st–D or 2nd–D); quick-shift button with 2 selectable modes; kick-down or kick-up/down		
Maximum Travel Speeds (with 35/65R33 tires)	<i>Forward</i>	<i>Reverse</i>	
Range 1	7.0 km/h (4.4 mph)	7.0 km/h (4.4 mph)	
Range 2	12.0 km/h (7.5 mph)	12.0 km/h (7.5 mph)	
Range 3	24.0 km/h (14.9 mph)	24.0 km/h (14.9 mph)	
Range 4	39.0 km/h (24.2 mph)	39.0 km/h (24.2 mph)	
Axles/Brakes			
Final Drives	Heavy-duty outboard-mounted double reduction		
Rear Axle Oscillation, Stop to Stop (with 35/65R33 tires)	24 deg. (12 deg. each direction)		
Brakes (conform to ISO 3450)			
Service	Hydraulically actuated, oil cooled, self-adjusting, multi disc		
Parking	Automatic spring applied, hydraulically released, final-drive integrated, oil cooled, multi disc		
Tires/Wheels (see page 15 for complete tire adjustments)			
	<i>Tread Width</i>	<i>Width Over Tires</i>	
Michelin 35/65R33 XTXL L4 3 Star	2720 mm (107 in.)	3729 mm (146.8 in.)	
Serviceability			
Refill Capacities			
Fuel Tank with Lockable Cap	761 L (201 gal.)		
Cooling System			
Engine	128 L (135 qt.)		
Power Electronics	17 L (18 qt.)		
Engine Oil with Vertical Spin-On Filter	44 L (46 qt.)		
Gearbox Reservoir with Vertical Filter	34 L (36 qt.)		
Wheel Motor and Final Drive Oil (each corner)	53 L (56 qt.)		
Generator/Pump Drive	34 L (36 qt.)		
Hydraulic Reservoir and Filter	378 L (100 gal.)		
Hydraulic System			
Pumps	Dual, variable-displacement, axial-piston pump; electronic displacement control with pressure cutoff		
Maximum Rated Flow at 6895 kPa (1,000 psi) and 1,800 rpm	379 L/m (100 gpm) each		
System Relief Pressure	35 000 kPa (5,000 psi)		
Loader Controls	Electrohydraulic (EH) 2-function valve; fingertip controls		

944K SPECIFICATIONS



Steering System		944K STANDARD BOOM / LONG BOOM
Pump	Variable-displacement, axial-piston pump; load sensing with pressure cutoff	
Maximum Rated Flow at 6895 kPa (1,000 psi) and 1,800 rpm	280 L/m (74 gpm)	
Steering (conforms to ISO 5010)		
Type	Power, fully hydraulic, pilot joystick steering	
Articulation Angle	80-deg. arc (40 deg. each direction)	
Turning Radius (measured to centerline of outside tire)	7.95 m (26 ft. 1 in.)	
Hydraulic Cycle Time		
Raise	7.0 sec.	
Dump	3.0 sec.	
Lower (float down)	3.5 sec.	
Total	13.5 sec.	

Dimensions and Specifications with Pin-On Bucket

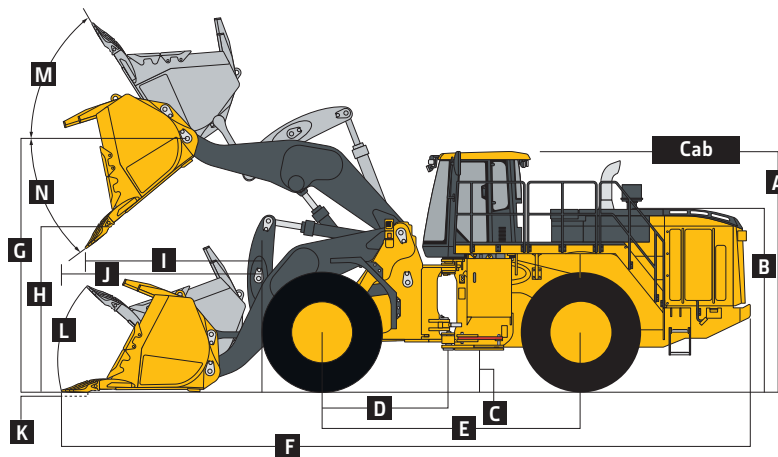

944K Z-BAR AND HIGH-LIFT LOADERS WITH PIN-ON BUCKET

Dimensions with Bucket	7.65-m ³ (10 cu. yd.) general-purpose pin-on bucket w/ bolt-on cutting (BOC) edge		6.88-m ³ (9.0 cu. yd.) spade-nose rock bucket w/ TK550 adapters and TK550LD penetration teeth kit		6.5-m ³ (8.5 cu. yd.) heavy-duty granite spade-nose rock bucket w/ TK550 adapters, wear liners, top cutting-edge protection, and TK550LDH abrasion teeth kit w/ Max Wear Protection	
	Standard Boom	Long Boom	Standard Boom	Long Boom	Standard Boom	Long Boom
A Height to Top of Cab	4.15 m (13 ft. 4 in.)	4.15 m (13 ft. 4 in.)	4.15 m (13 ft. 4 in.)	4.15 m (13 ft. 4 in.)	4.15 m (13 ft. 4 in.)	4.15 m (13 ft. 4 in.)
B Hood Height	3.13 m (10 ft. 3.4 in.)	3.13 m (10 ft. 3.4 in.)	3.13 m (10 ft. 3.4 in.)	3.13 m (10 ft. 3.4 in.)	3.13 m (10 ft. 3.4 in.)	3.13 m (10 ft. 3.4 in.)
C Ground Clearance	582 mm (22.9 in.)	582 mm (22.9 in.)	582 mm (22.9 in.)	582 mm (22.9 in.)	582 mm (22.9 in.)	582 mm (22.9 in.)
D Length from Centerline to Front Axle	2.25 m (7 ft. 4.6 in.)	2.25 m (7 ft. 4.6 in.)	2.25 m (7 ft. 4.6 in.)	2.25 m (7 ft. 4.6 in.)	2.25 m (7 ft. 4.6 in.)	2.25 m (7 ft. 4.6 in.)
E Wheelbase	4.5 m (14 ft. 9.2 in.)	4.5 m (14 ft. 9.2 in.)	4.5 m (14 ft. 9.2 in.)	4.5 m (14 ft. 9.2 in.)	4.5 m (14 ft. 9.2 in.)	4.5 m (14 ft. 9.2 in.)
F Overall Length, Bucket on Ground	11.69 m (38 ft. 4.2 in.)	11.91 m (39 ft. 0.9 in.)	12.16 m (39 ft. 10.7 in.)	12.38 m (40 ft. 7.4 in.)	12.17 m (39 ft. 11 in.)	12.39 m (40 ft. 7.8 in.)
G Height to Hinge Pin, Fully Raised	5.35 m (17 ft. 6.6 in.)	5.81 m (19 ft. 0.7 in.)	5.35 m (17 ft. 6.6 in.)	5.81 m (19 ft. 0.7 in.)	5.35 m (17 ft. 6.6 in.)	5.81 m (19 ft. 0.7 in.)
H Dump Clearance, 45 deg., Full Height	3.77 m (12 ft. 4.4 in.)	4.22 m (13 ft. 10.1 in.)	3.43 m (11 ft. 3.0 in.)	3.89 m (12 ft. 9.1 in.)	3.42 m (11 ft. 2.6 in.)	3.88 m (12 ft. 8.8 in.)
I Reach, 45-deg. Dump, Full Height	1.80 m (5 ft. 10.7 in.)	1.69 m (5 ft. 6.5 in.)	2.12 m (6 ft. 11.5 in.)	2.01 m (6 ft. 7.1 in.)	2.12 m (6 ft. 11.5 in.)	2.02 m (6 ft. 7.5 in.)
J Reach, 45-deg. Dump, 2.13-m (7 ft.) Clearance	2.87 m (9 ft. 5.0 in.)	3.09 m (10 ft. 1.7 in.)	2.93 m (9 ft. 7.4 in.)	3.17 m (10 ft. 4.8 in.)	2.93 m (9 ft. 7.4 in.)	3.17 m (10 ft. 4.8 in.)
K Maximum Digging Depth	0.26 m (10.2 in.)	0.25 m (9.8 in.)	0.26 m (10.2 in.)	0.25 m (9.8 in.)	0.27 m (10.6 in.)	0.25 m (9.8 in.)
L Maximum Rollback at Ground Level	43 deg.	43 deg.	48 deg.	48 deg.	48 deg.	48 deg.
M Maximum Rollback, Boom Fully Raised	64 deg.	64 deg.	69 deg.	69 deg.	69 deg.	69 deg.
N Maximum Bucket Dump Angle, Fully Raised	50 deg.	50 deg.	45 deg.	45 deg.	45 deg.	45 deg.
Loader Clearance Circle, Bucket Carry Position	17.78 m (58 ft. 4.1 in.)	17.97 m (58 ft. 11.7 in.)	17.85 m (58 ft. 5.7 in.)	18.02 m (59 ft. 1.6 in.)	17.86 m (58 ft. 6.0 in.)	18.04 m (59 ft. 2.2 in.)

**Dimensions and Specifications
with Pin-On Bucket (continued)**

944K STANDARD BOOM / LONG BOOM

Specifications with Bucket	<i>7.65-m³ (10 cu. yd.) general-purpose pin-on bucket w/ bolt-on cutting (BOC) edge</i>		<i>6.88-m³ (9.0 cu. yd) spade-nose rock bucket w/ TK550 adapters and TK550LD penetration teeth kit</i>		<i>6.5-m³ (8.5 cu. yd) heavy-duty granite spade-nose rock bucket w/ TK550 adapters, wear liners, top cutting-edge protection, and TK550LDH abrasion teeth kit w/ Max Wear Protection</i>	
	<i>Standard Boom</i>	<i>Long Boom</i>	<i>Standard Boom</i>	<i>Long Boom</i>	<i>Standard Boom</i>	<i>Long Boom</i>
Capacity, Heaped	7.65 m ³ (10.0 cu. yd.)	7.65 m ³ (10.0 cu. yd.)	6.88 m ³ (9.0 cu. yd)	6.88 m ³ (9.0 cu. yd)	6.50 m ³ (8.5 cu. yd.)	6.50 m ³ (8.5 cu. yd.)
Capacity, Struck	6.60 m ³ (8.60 cu. yd.)	6.60 m ³ (8.60 cu. yd.)	6.25 m ³ (8.15 cu. yd.)	6.25 m ³ (8.15 cu. yd.)	5.80 m ³ (7.60 cu. yd.)	5.80 m ³ (7.60 cu. yd.)
Bucket Weight with Bolt-On Cutting Edge	5529 kg (12,190 lb.)	5529 kg (12,190 lb.)	5760 kg (12,698 lb.)	5760 kg (12,698 lb.)	7375 kg (16,259 lb.)	7375 kg (16,259 lb.)
Bucket Width						
Without Side Kickers	3.92 m (12 ft. 10.5 in.)	3.92 m (12 ft. 10.5 in.)	4.06 m (13 ft. 4.0 in.)	4.06 m (13 ft. 4.0 in.)	4.06 m (13 ft. 4.0 in.)	4.06 m (13 ft. 4.0 in.)
With Side Kickers	4.45 m (14 ft. 7.0 in.)	4.45 m (14 ft. 7.0 in.)	4.45 m (14 ft. 7.0 in.)	4.45 m (14 ft. 7.0 in.)	4.45 m (14 ft. 7.0 in.)	4.45 m (14 ft. 7.0 in.)
Breakout Force	46,896 kg (103,388 lb.)	47 753 kg (105,277 lb.)	37 103 kg (81,798 lb.)	37 784 kg (83,299 lb.)	36 227 kg (79,867 lb.)	36 908 kg (81,368 lb.)
Tipping Load, Straight						
No Tire Deflection	38 059 kg (83,906 lb.)	35 295 kg (77,812 lb.)	38 789 kg (85,515 lb.)	35 871 kg (79,082 lb.)	36 600 kg (80,689 lb.)	33 708 kg (74,313 lb.)
With Tire Deflection	36 444 kg (80,345 lb.)	33 786 kg (74,485 lb.)	37 113 kg (81,820 lb.)	34 314 kg (75,649 lb.)	34 974 kg (77,104 lb.)	32 196 kg (70,980 lb.)
Tipping Load, 37-deg. Partial Turn, No Tire Deflection	33 659 kg (74,205 lb.)	31 116 kg (68,599 lb.)	34 278 kg (75,570 lb.)	31 597 kg (69,659 lb.)	32 124 kg (70,821 lb.)	29 467 kg (64,964 lb.)
Tipping Load, 40-deg. Full Turn						
No Tire Deflection	32 947 kg (72,636 lb.)	30 440 kg (67,108 lb.)	33 548 kg (73,960 lb.)	30 906 kg (68,136 lb.)	31 400 kg (69,225 lb.)	28 781 kg (63,451 lb.)
With Tire Deflection	30 954 kg (68,241 lb.)	28 563 kg (62,971 lb.)	31 488 kg (69,419 lb.)	28 977 kg (63,883 lb.)	29 394 kg (64,802 lb.)	26 904 kg (59,313 lb.)
Rated Operating Capacity, 50% Full-Turn Tipping Load, with Tire Deflection (conforms to ISO 14397-1)*	15 477 kg (34,121 lb.)	14 282 kg (31,485 lb.)	15 744 kg (34,710 lb.)	14 489 kg (31,943 lb.)	14 697 kg (32,401 lb.)	13 452 kg (29,657 lb.)
Operating Weight	53 500 kg (117,947 lb.)	54 294 kg (119,698 lb.)	53 730 kg (118,454 lb.)	54 524 kg (120,205 lb.)	55 345 kg (122,014 lb.)	56 139 kg (123,765 lb.)

Loader operating information is based on machine with identified linkage and standard equipment, PowerTech PSX 6135 (EPA Interim Tier 4/EU Stage IIIB) engine, ROPS cab, rear cast bumper/counterweight, transmission side-frame guards, bottom guards, standard tires, full fuel tank, and 79-kg (175 lb.) operator. This information is affected by changes in tires, ballast, and different attachments.

**Rated operating capacity based on Deere attachments only.*

Adjustments to Operating Weights and Tipping Loads with Buckets

944K STANDARD BOOM / LONG BOOM

Adjustments to operating weights, tipping loads, and tires are based on Z-Bar machine with pin-on 6.88-m³ (9.0 cu. yd.) spade-nose rock bucket with bolt-on cutting edge, ROPS cab, rear cast bumper/counterweight, transmission side-frame guards, bottom guards, standard tires, full fuel tank, and 79-kg (175 lb.) operator*

Add (+) or deduct (-) kg (lb.) as indicated for loaders with 3-piece rims	Operating Weight	Tipping Load, Straight	Tipping Load, 37-deg. Partial Turn	Tipping Load, 40-deg. Full Turn	Tread Width	Width Over Tires	Vertical Height	Rated Operating Capacity
Michelin 35/65R33 XTXL L4 3 Star	0 kg (0 lb.)	0 kg (0 lb.)	0 kg (0 lb.)	0 kg (0 lb.)	0 mm (0 in.)	0 mm (0 in.)	0 mm (0 in.)	0 kg (0 lb.)
Bridgestone 35/65R33 VSNT L4 2 Star	+707 kg (+1,557 lb.)	+521 kg (+1,149 lb.)	+469 kg (+1,034 lb.)	+461 kg (+1,016 lb.)	0 mm (0 in.)	0 mm (0 in.)	+23 mm (+0.9 in.)	+231 kg (+508 lb.)
Michelin 35/65R33 XLDD2 L5 2 Star	+491 kg (+1,082 lb.)	+607 kg (+1,338 lb.)	+548 kg (+1,208 lb.)	+539 kg (+1,188 lb.)	0 mm (0 in.)	0 mm (0 in.)	+62 mm (+2.4 in.)	+270 kg (+595 lb.)
Michelin 35/65R33 XMINED2 L5 2 Star	+1007 kg (+2,220 lb.)	+876 kg (+1,931 lb.)	+789 kg (+1,739 lb.)	+775 kg (+1,709 lb.)	0 mm (0 in.)	+14 mm (+0.6 in.)	+19 mm (+0.7 in.)	+388 kg (+855 lb.)
Bridgestone 35/65R33 VSDL L5 2 Star	+1307 kg (+2,881 lb.)	+1363 kg (+3,005 lb.)	+1229 kg (+2,709 lb.)	+1208 kg (+2,663 lb.)	0 mm (0 in.)	-27 mm (-1.06 in.)	+19 mm (+0.7 in.)	+604 kg (+1,332 lb.)
Bridgestone 35/65-33 DL L5 42Ply	+1747 kg (+3,851 lb.)	+1630 kg (+3,594 lb.)	+1469 kg (+3,239 lb.)	+1443 kg (+3,181 lb.)	0 mm (0 in.)	-11 mm (-0.4 in.)	+53 mm (+2.1 in.)	-2425 kg (-5,346 lb.)

*May change based on vehicle configuration, weight, or tire-pressure adjustments.

Bucket Selection Guide

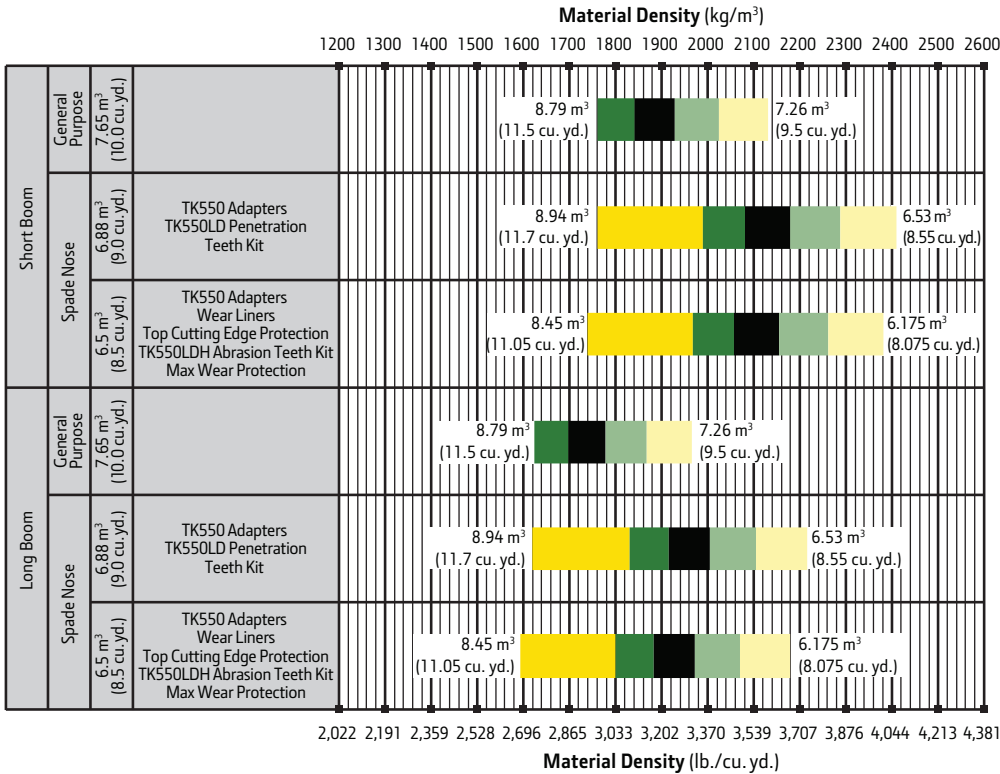

LOOSE MATERIALS	kg/m ³	lb./cu. yd.
Chips, pulpwood	288	486
Cinders (coal, ashes, clinkers)	673	1,134
Clay and gravel, dry	1602	2,700
Clay, compact, solid	1746	2,943
Clay, dry in lump loose	1009	1,701
Clay, excavated in water	1282	2,160
Coal, anthracite, broken, loose	865	1,458
Coal, bituminous, moderately wet	801	1,350
Earth, common loam, dry	1218	2,052
Earth, mud, packed	1843	3,105
Granite, broken	1538	2,592
Gypsum	2275	3,834
Limestone, coarse, sized	1570	2,646
Limestone, mixed sizes	1682	2,835
Limestone, pulverized or crushed	1362	2,295
Sand, damp	2083	3,510
Sand, dry	1762	2,970
Sand, voids, full of water	2083	3,510
Sandstone, quarried	1314	2,214
Shale, broken crushed	1362	2,295
Slag, furnace granulated	1955	3,294
Stone or gravel, 37.5 to 87.5-mm (1.5 to 3.5") size	1442	2,430
Stone or gravel, 18.75-mm (3/4") size	1602	2,700

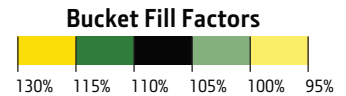

Additional equipment

Key: ● Standard ▲ Optional or special

See your John Deere dealer for further information.

944K Engine

- Wet-sleeve cylinder liners
- Programmable auto-idle and auto shutdown
- Selected idle adjustment from 900–1,250 rpm
- Starter protection
- Automatic derating for exceeded system temperatures
- Serpentine drive belt for automatic tensioner
- Electrical fuel-priming pump
- Dual-stage fuel filter and water separator
- 500-hour vertical spin-on oil filter
- Engine-compartment light
- ▲ Chrome exhaust stack
- ▲ Automatic ether starting aid (recommended for cold starts below –12 deg. C [10 deg. F])
- ▲ Engine-block heater (recommended for cold starts below –23 deg. C [–10 deg. F])
- Centrifugal engine air pre-cleaner

Powertrain

- Hybrid-electric drivetrain
- Brushless A/C electric motor at each wheel
- Brushless A/C electric generators (2)
- Solid-state power electronics
- Programmable maximum high-speed range
- Drivetrain diagnostic ports
- Automatic traction control
- Rimpull control
- Coast control
- Self-adjusting wet-disc brakes
- Spring-applied, hydraulically released, wet multi-disc park brake

Quad-Cool™ Cooling System

- Heavy-duty, dust-resistant radiator and high-ambient cooling package
- 2-side access to all coolers
- Isolated from engine compartment
- Integral engine oil cooler
- Hydraulic oil cooler (oil to air)
- Charge air cooler (air to air)
- Engine radiator
- Generator and pump-drive gearbox cooler (oil to air)
- Power electronics cooler (antifreeze to air)
- Wheel motor, service brake, and final-drive oil coolers (oil to air)
- Coolant recovery tank
- Antifreeze, –37 deg. C (–34 deg. F)
- Cool-on-demand, hydraulically driven, swing-out fan
- Enclosed fan safety guard
- ▲ Automatic reversing fan drive

Hydraulics

- Electronically controlled load-sensing hydraulic system
- Electrohydraulic (EH) controls
- 2 function — 2-lever fingertip controls
- In-cab adjustable automatic return-to-dig bucket positioner
- In-cab adjustable automatic boom-height kickout/return to carry
- Reservoir with sight gauge and fill strainer
- Hydraulic diagnostic ports
- 4,000-hour in-tank filters
- ▲ Ride control, automatic with monitor-adjustable speed settings

944K Hydraulics (continued)

- ▲ Hydrau™ XR cold-temperature hydraulic fluid recommended below –25 deg. C. (–13 deg. F)

Steering Systems

- Joystick steering with range shift, F-N-R, and horn
- 40-deg. steering articulation to each side with rubber-cushion stops on frame and hydraulic-relief valves
- ▲ Secondary steering

Electrical

- 150-amp alternator
- Batteries (2), 1,400 CCA each
- ▲ Batteries (4), 1,400 CCA each
- Solid-state electrical power-distribution system
- Lockable master electrical-disconnect switch
- Starter and engine lockout in bumper
- By-pass start safety cover at starter
- Pre-wired for beacon/strobe light
- Halogen driving and work lights: Front loader mast (2), front cab (4), rear cab (2), rear grille (2), rear platform, LED front marker/turn lights, and LED stop- and taillights
- ▲ Premium LED driving and work lights: Front loader mast (2), front cab (4), rear cab (2), rear grille (2), rear platform halogen (2), LED front marker/turn lights, and LED stop- and taillights
- ▲ Deluxe LED driving and work lights: Front loader mast (4), front cab (6), rear cab (2), rear grille (2), rear platform halogen (2), LED front marker/turn lights, and LED stop- and taillights

- Programmable courtesy lights
- Stairway lighting with ground-level and in-cab switches
- Horn, electric
- Reverse warning alarm

- Multifunction/multi-language LCD color monitor includes: Digital instruments — Analog display (hydraulic oil temperature, engine coolant temperature, drive system oil temperature, and engine oil pressure) / Digital display (engine rpm, drive system range/direction indicator, hour meter, fuel level, speedometer, odometer, average fuel consumption, and outside temperature)

- Integrated cycle counter with 5 categories
- Indicator lights: Standard and selected options / Amber caution and red stop
- Operator-warning messages
- Built-in diagnostics: Diagnostic-code details / Sensor values / Calibrations / Individual circuit tester

- ▲ Electrical corrosion-prevention package
- ▲ AM/FM/Weather Band (WB) radio with remote auxiliary port
- ▲ Premium AM/FM/WB/XM Satellite Radio™ ready radio with Bluetooth®, remote auxiliary port, and remote USB port

- 24- to 12-volt, 8-amp converter
- ▲ 24- to 12-volt, 15- or 30-amp converter

Operator's Station

- Quiet Cab with air conditioning/heater (ROPS/FOPS Level 1, isolation mounted)
- Keyless start with multiple security modes
- Sealed-switch module with function indicators
- Premium seat with high-wide back and headrest extension, heated, leather/fabric cover, and adjustable air suspension

944K Operator's Station (continued)

- Hydraulic controls integrated to seat
- High-visibility, bright-orange seat belt, 76 mm (3 in.), with retractor
- Cup holder
- Lunch-box/cooler holder
- Dome and reading light
- 12-volt power ports (2)
- Rubber floor mat
- Operator's manual storage compartment
- Outside (2) and inside (1) rearview mirrors
- ▲ Large heated outside mirrors
- Left-side operator-station access
- Sun visor
- Radio ready
- Front and rear intermittent windshield wiper and washers
- Powered cab air pre-cleaner
- ▲ Beacon bracket
- ▲ Rear camera and radar object-detection system
- ▲ Fire extinguisher
- Certified tie-off points on cab roof

Loader Linkage

- Z-Bar standard-length boom loader linkage
- ▲ Z-Bar long boom loader linkage

Overall Vehicle

- JDLink™ Ultimate wireless communication system (available in specific countries; see your dealer for details)
- Bushed pin joints (including static joints on bucket and steering cylinders)
- ▲ Hydraulically driven Lincoln Centro-Matic® automatic lubrication system
- Front, mid, and rear tie-downs
- Rear cast bumper with rear hitch and locking pin
- Articulation locking bar
- Vandal protection with lockable engine enclosures, right counterweight storage, battery box, and filler access for radiator/fuel/hydraulic transmission
- Right and left handrails, platforms with toe kicks, and steps
- Slip-resistant steps and ergonomic handholds
- Right-side ground-level service center
- Storage compartment
- Ground-level fuel fill with strainer
- ▲ Fast-fuel system
- Heavy-duty fuel-tank guard
- Same-side daily servicing
- Environmental drains for engine, drive system, hydraulic oils, and engine coolant
- Fluid-sampling ports for engine, drive system, hydraulic and final-drive oils, and coolants
- 35/65-33 or 35/65R33 tires on 5-piece rims
- ▲ Tire-pressure monitoring system
- Level 1 sound package
- Level 2 sound package
- Transmission side-frame and crankcase guards
- Front-frame bottom guard
- ▲ Quick fluid service (engine, transmission, hydraulic oils, and engine coolant)
- Fenders, front and rear
- ▲ Roading fenders, full-coverage, front and rear

Net engine power is with standard equipment including air cleaner, exhaust system, alternator, and cooling fan at test conditions per ISO 9249.

No derating is required up to 3050-m (10,000 ft.) altitude. Specifications and design subject to change without notice. Specifications with the exception of bucket capacity are in accordance with all applicable ISO standards. Except where otherwise noted, these specifications are based on a unit with applicable linkage and standard equipment, ROPS cab, rear cast bumper/counterweight, transmission side-frame and crankcase guards, front-frame bottom guard, standard tires, full fuel tank, and 79-kg (175 lb.) operator.

