

904 P

Wheel Loader



JOHN DEERE





9.8- & 9.3-CU.-YD. BUCKETS
CAN LOAD STANDARD
OVER-THE-ROAD TRUCKS
IN JUST 2 PASSES

PRIMED FOR PRODUCTIVITY

SEE IT LIKE NEVER BEFORE

New Advanced Vision System includes two digital cameras mounted on the rearview-mirror platforms that integrate with the rearview camera for a single display on a dedicated in-cab monitor. Overlaid within the monitor's rear-camera view, dynamic reversal projected-path lines help operators visualize the loader's anticipated reversal path based on its articulation, for sight lines to people or objects directly within the path.



LARGE AND IN CHARGE

READY TO DO THE HEAVY LIFTING

Combining serious performance with fuel efficiency, customer-inspired components, and intuitive controls, our 904 P-Tier provides the muscle operators need to work productively and comfortably. Enhancements include increased horsepower and hydraulic pressure, reimagined cab amenities, and simplified service points. With its rugged EPA Final Tier 4/EU Stage V-compliant John Deere PowerTech™ diesel, hefty material-handling buckets, and a wealth of proven options, this large-scale wheel loader is built rock solid for the long haul.

Power things up

Power into the aggregate pile with greater engine torque and 28 additional horsepower compared to earlier models, plus 12 more horsepower than the 844 P-Tier.

Get a handle on it

Rugged 9.8- and 9.3-cubic-yard material-handling buckets with integrated spill guards and curved side cutters are designed to heap heavier loads of processed aggregates in fewer passes and maximize load retention while providing clear visibility to the jobsite ahead.

Payload plan

Larger rear cast bumper/counterweight enables the 904 P-Tier to handle an 11-percent greater payload than earlier models.

Cycle through

Tilt cylinders that are 12-percent larger deliver more breakout force than previous designs. Increased hydraulic pressure helps make repetitive bucket loading, unloading, and reloading seem like no big deal.

Material matters

SmartWeigh option features dynamic weighing technology that allows operators to weigh without interrupting workflow and removes the need to lower and reraise the boom after tipoff. Shared through the onboard monitor, SmartWeigh is easy to calibrate and effortlessly integrates with JDLink™ so you can track and visualize payload data from almost anywhere. Available as a factory-installed or field-kit option, you can also try SmartWeigh at a low cost for 250 machine hours.

Precision Construction

From grade management and obstacle detection to product automation features and jobsite intelligence, this suite of construction technology delivers productivity solutions to help you get more done, more efficiently.

John Deere construction equipment comes with in-base connectivity — free from subscriptions or annual renewals. Analyze critical machine data, track utilization, review diagnostic alerts, and more from **the John Deere Operations Center™**. The Operations Center also enables **John Deere Connected Support™**, which uses data from thousands of connected machines to proactively address issues before they arise. Your dealer can also remotely monitor machine health, diagnose problems, and even update machine software without a trip to the jobsite.*

*Availability varies by region and product. Options not available in every country.



SMARTWEIGH™
PAYLOAD-WEIGHING SOLUTION
IS DEERE DESIGNED & SUPPORTED



904 P

WHEEL LOADER



**OPTIONAL AUTO-LUBE SYSTEM
SAVES TIME & HASSLE**



YOU THOUGHT OF EVERYTHING IT'S IN THE DETAILS.

Your best ideas have helped our large wheel loaders stand out on the jobsite and in the industry. These are just some of the purpose-built details that add up to push our 904 P-Tier – and your operation – to the next level.



Make the shift

Smooth-shifting standard transmission with lockup torque converter delivers impressive acceleration and cycle times. Design optimizes power and fuel efficiency during transport, roading, and ramp climbing.

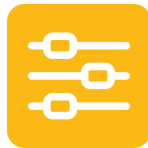

It's easy to take control

Easier and more intuitive to operate than the controls on previous models, seat-mounted right-hand hydraulic controls feature two programmable multifunction buttons with electrohydraulic (EH) controls.



Outsized comfort

Cab boasts three more inches of legroom than previous models. Standard premium heated/ventilated seat, updated HVAC system with automatic temperature control, and redesigned sealed-switch module are placed for ergonomic comfort and convenience. A 79-percent-wider door than on L-Series models makes getting in and out easier.



Heavy-duty durability

Large, high-capacity, heavy-duty axles with standard axle cooling and filtration increase durability in demanding conditions compared to previous models.



Move things forward

Low-profile tire options improve traction, flotation, and stability over standard tires.



On the winning side

All daily service points including fuel are conveniently grouped on the left side of the machine for easy access.



While general information, pictures, and descriptions are provided, some illustrations and text may include product options and accessories NOT AVAILABLE in all regions, and in some countries products and accessories may require modifications or additions to ensure compliance with the local regulations of those countries.

Engine		904 P-TIER	
Manufacturer and Model	John Deere PowerTech™ PSS 6135	Fuel System	Mechanically actuated electronic unit injectors
Non-Road Emission Standard	EPA Final Tier 4/EU Stage V	Lubrication	Full-flow spin-on filter and integral cooler
Cylinders	6	Aspiration	Series turbocharged, charge air cooled
Valves per Cylinder	4	Air Cleaner	Dual-element dry type, restriction indicator in cab monitor for service; additional centrifugal engine pre-cleaner
Displacement	13.5 L (824 cu. in.)		
Net Peak Power (ISO 9249)	320 kW (429 hp) at 1,400 rpm		
Net Peak Torque (ISO 9249)	2184 Nm (1,611 lb.-ft.) at 1,400 rpm		
Net Torque Rise	44%		
Cooling			
Fan Drive	Hydraulically driven, proportionally controlled, fan aft of coolers; automatic reversing fan drive		
Electrical			
Electrical System	24 volt with 150-amp alternator		
Batteries (2 – 12 volt)	1,400 CCA (each)		
Transmission System			
Type	Countershaft-type PowerShift™ with lockup torque converter		
Torque Converter	Single stage, dual phase with freewheeling stator with lockup clutch		
Shift Control	Electronically modulated, adaptive, load and speed dependent		
Operator Interface	Steering-column or joystick-mounted F-N-R and gear-select lever; Quick-Shift button on hydraulic lever		
Shift Modes	Manual/auto (1st–5th or 2nd–5th); Quick-Shift button with 2 selectable modes: kick-down or kick-up/down; and 4 settings for clutch cutoff		
Maximum Travel Speeds (with 875/65R29 L3 tires)	<i>Standard 5-Speed With Lockup Torque Converter</i>		
	<i>Forward</i>	<i>Reverse</i>	
Range 1	6.4 km/h (4.0 mph)	6.4 km/h (4.0 mph)	
Range 2	11.5 km/h (7.1 mph)	11.6 km/h (7.1 mph)	
Range 3	17.4 km/h (10.8 mph)	24.7 km/h (15.3 mph)	
Range 4	24.6 km/h (15.3 mph)	N/A	
Range 5	40.0 km/h (24.9 mph)	N/A	
Axles/Brakes			
Final Drives	Heavy-duty mid-board planetary		
Differentials	Conventional front and rear axles		
Rear Axle Oscillation, Stop to Stop, With 875/65R29 L3 Tires	16 deg. (8 deg. each direction)		
Brakes (conform to ISO 3450)			
Service	Outboard, forced oil cooled, multi disc		
Parking	Automatic spring applied, hydraulically released, sealed wet multi disc		
Tires/Wheels			
<i>(see page 9 for complete tire adjustments)</i>			
	<i>Tread Width</i>	<i>Width Over Tires</i>	
Michelin 875/65R29, 1 Star L-3	2440 mm (96.1 in.)	3408 mm (134.2 in.)	
Serviceability			
Refill Capacities		Refill Capacities (continued)	
Fuel Tank (with ground-level fueling)	534 L (141 gal.)	Transmission Reservoir With Vertical Filter	28 L (29.5 qt.)
Diesel Exhaust Fluid (DEF)	26.3 L (6.9 gal.)	Axle Oil (front and rear, each)	68 L (72 qt.)
Cooling System	78.75 L (83.2 qt.)	Hydraulic Reservoir and Filter	181.7 L (48 gal.)
Engine Oil With Vertical Spin-On Filter	40 L (42.3 qt.)	Park Brake Oil (wet disc)	0.7 L (24 oz.)
Hydraulic System/Steering			
Loader Pumps	2 variable-displacement, load-sensing axial-piston pumps; closed-center system		
Maximum Rated Flow at 6895 kPa (1,000 psi) at 2,000 rpm	570 L/m (150.5 gpm)		
System Relief Pressure	27 600 kPa (4,000 psi)		
Steering Pump	1 variable-displacement, load-sensing axial-piston pump; closed-center system		
Maximum Rated Flow at 6895 kPa (1,000 psi) at 2,000 rpm	199.5 L/m (52.7 gpm)		
System Relief Pressure	24 900 kPa (3,611 psi)		

904 P-TIER WHEEL LOADER SPECIFICATIONS

904

P

While general information, pictures, and descriptions are provided, some illustrations and text may include product options and accessories NOT AVAILABLE in all regions, and in some countries products and accessories may require modifications or additions to ensure compliance with the local regulations of those countries.

Hydraulic System/Steering (continued) 904 P-TIER

Loader Controls	2-function valve; single- or dual-lever controls; control lever lockout feature
Steering (conforms to ISO 5010)	
Type	Power, fully hydraulic; single-lever control and adjustable wristrest with conventional steering wheel override
Articulation Angle	80-deg. arc (40 deg. each direction)
Turning Radius (measured to centerline of outside tire)	6.30 m (20 ft. 8 in.)
Hydraulic Cycle Times <i>Standard Lift</i>	
Raise	5.9 sec.
Dump	2.3 sec.
Lower (float down)	3.6 sec.
Total	11.8 sec.

Dimensions and Specifications With Pin-On Bucket

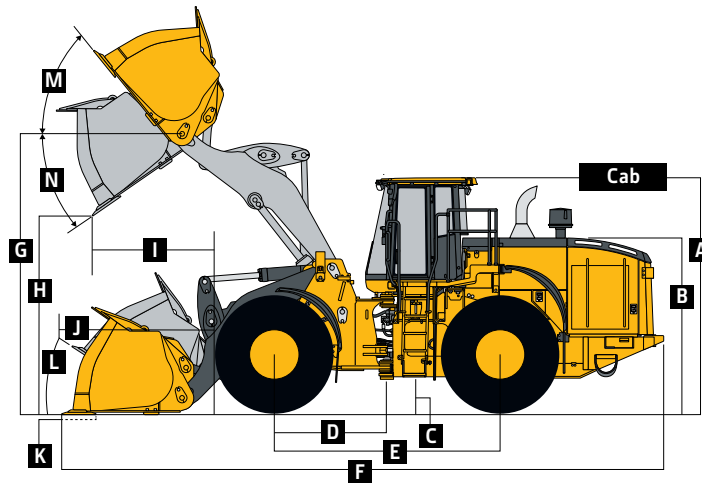

904 P-TIER WHEEL LOADER WITH PIN-ON BUCKET

Dimensions With Bucket	71-m ³ (9.3 cu. yd.) material-handling enhanced performance with bolt-on edge	75-m ³ (9.8 cu. yd.) material-handling enhanced performance with bolt-on edge	75-m ³ (9.8 cu. yd.) narrow material-handling enhanced performance with bolt-on edge
A Height to Top of Cab	3.73 m (12 ft. 3 in.)	3.73 m (12 ft. 3 in.)	3.73 m (12 ft. 3 in.)
B Hood Height	2.74 m (9 ft. 0 in.)	2.74 m (9 ft. 0 in.)	2.74 m (9 ft. 0 in.)
C Ground Clearance	463 mm (18.2 in.)	463 mm (18.2 in.)	463 mm (18.2 in.)
D Length From Centerline to Front Axle	1.85 m (6 ft. 1 in.)	1.85 m (6 ft. 1 in.)	1.85 m (6 ft. 1 in.)
E Wheelbase	3.70 m (12 ft. 2 in.)	3.70 m (12 ft. 2 in.)	3.70 m (12 ft. 2 in.)
F Overall Length, Bucket on Ground	10.00 m (32 ft. 10 in.)	10.07 m (33 ft. 0 in.)	10.35 m (33 ft. 11 in.)
G Height to Hinge Pin, Fully Raised	4.60 m (15 ft. 1 in.)	4.60 m (15 ft. 1 in.)	4.60 m (15 ft. 0 in.)
H Dump Clearance, 45 deg., Full Height	3.12 m (10 ft. 3 in.)	3.08 m (10 ft. 1 in.)	2.90 m (9 ft. 6 in.)
I Reach, 45-deg. Dump, Full Height	1.71 m (5 ft. 7 in.)	1.76 m (5 ft. 9 in.)	1.97 m (6 ft. 6 in.)
J Reach, 45-deg. Dump, 213-mm (7 ft. 0 in.) Clearance	2.41 m (7 ft. 11 in.)	2.44 m (8 ft. 0 in.)	2.56 m (8 ft. 5 in.)
K Maximum Digging Depth	110 mm (4.4 in.)	116 mm (4.6 in.)	117 mm (4.6 in.)
L Maximum Rollback at Ground Level	45.2 deg.	40.2 deg.	40.2 deg.
M Maximum Rollback, Boom Fully Raised	59.8 deg.	59.8 deg.	59.8 deg.
N Maximum Bucket Dump Angle, Fully Raised	46.2 deg.	46.2 deg.	46.2 deg.
Loader Clearance Circle, Bucket Carry Position	15.35 m (50 ft. 4 in.)	15.39 m (50 ft. 6 in.)	14.98 m (49 ft. 2 in.)

904 P-TIER

While general information, pictures, and descriptions are provided, some illustrations and text may include product options and accessories NOT AVAILABLE in all regions, and in some countries products and accessories may require modifications or additions to ensure compliance with the local regulations of those countries.

Dimensions and Specifications			
With Pin-On Bucket <i>(continued)</i>	904 P-TIER		
	<i>7.1-m³ (9.3 cu. yd.) material-handling enhanced performance with bolt-on edge</i>	<i>7.5-m³ (9.8 cu. yd.) material-handling enhanced performance with bolt-on edge</i>	<i>7.5-m³ (9.8 cu. yd.) narrow material-handling enhanced performance with bolt-on edge</i>
Specifications With Bucket			
Capacity, Heaped	7.1 m ³ (9.3 cu. yd.)	7.5 m ³ (9.8 cu. yd.)	7.5 m ³ (9.8 cu. yd.)
Capacity, Heaped at 110% Fill Factor	7.8 m ³ (10.23 cu. yd.)	8.25 m ³ (10.78 cu. yd.)	8.25 m ³ (10.78 cu. yd.)
Capacity, Struck	5.9 m ³ (7.7 cu. yd.)	6.2 m ³ (8.1 cu. yd.)	6.6 m ³ (8.6 cu. yd.)
Bucket Weight With Bolt-On Cutting Edge	4096 kg (9,030 lb.)	4218 kg (9,300 lb.)	4074 kg (8,981 lb.)
Bucket Width	3.65 m (12 ft. 0 in.)	3.65 m (12 ft. 0 in.)	3.00 m (9 ft. 10 in.)
Breakout Force	25 308 kg (55,795 lb.)	24 311 kg (53,596 lb.)	21 080 kg (46,473 lb.)
Tipping Load, Straight, No Tire Deflection	27 287 kg (60,157 lb.)	27 144 kg (59,842 lb.)	26 774 kg (59,026 lb.)
Tipping Load, Straight, With Tire Deflection	25 671 kg (56,595 lb.)	25 527 kg (56,277 lb.)	25 125 kg (55,391 lb.)
Tipping Load, 37-deg. Partial Turn	23 970 kg (52,845 lb.)	23 827 kg (52,530 lb.)	23 501 kg (51,811 lb.)
Tipping Load, 40-deg. Full Turn, No Tire Deflection	23 433 kg (51,661 lb.)	23 290 kg (51,347 lb.)	22 971 kg (50,642 lb.)
Tipping Load, 40-deg. Full Turn, With Tire Deflection	21 396 kg (47,170 lb.)	21 252 kg (46,853 lb.)	20 892 kg (46,059 lb.)
Rated Operating Load, 50% Full-Turn Tipping Load, With Tire Deflection (conforms to ISO 14397-1)*	10 698 kg (23,585 lb.)	10 626 kg (23,426 lb.)	10 446 kg (23,029 lb.)
Operating Weight	36 310 kg (80,050 lb.)	36 432 kg (80,318 lb.)	36 393 kg (80,233 lb.)
<i>Loader operating information is based on machine with identified linkage and standard equipment, PowerTech PSS 6135 (EPA Final Tier 4/EU Stage V) engine, ROPS cab, rear cast bumper/counterweight, transmission side-frame guards, bottom guards, standard tires, full fuel tank, and 79-kg (175 lb.) operator. This information is affected by changes in tires, ballast, and different attachments.</i>			
<i>*Rated operating capacity based on Deere attachments only.</i>			

While general information, pictures, and descriptions are provided, some illustrations and text may include product options and accessories NOT AVAILABLE in all regions, and in some countries products and accessories may require modifications or additions to ensure compliance with the local regulations of those countries.

Adjustments to Operating Weights and Tipping Loads With Buckets

904 P-TIER

Adjustments to operating weights, tipping loads, and tires are based on machine with pin-on 7.1-m³ (9.3 cu. yd.) material-handling bucket with bolt-on cutting edge, ROPS cab, rear cast bumper/counterweight, transmission side-frame guards, bottom guards, standard tires, full fuel tank, and 79-kg (175 lb.) operator*

Add (+) or deduct (-) kg (lb.) as indicated for loaders with 3-piece rims	Operating Weight	Tipping Load, Straight	Tipping Load,		Tread Width	Width Over Tires	Vertical Height
			37-deg. Partial Turn	40-deg. Full Turn			
Michelin 875/65R29, 1 Star L-3 [§]	0 kg (0 lb.)	0 kg (0 lb.)	0 kg (0 lb.)	0 kg (0 lb.)	0 mm (0 in.)	0 mm (0 in.)	0 mm (0 in.)
Bridgestone 875/65R29, 1 Star L-3 [§]	+388 kg (+855 lb.)	+285 kg (+628 lb.)	+256 kg (+564 lb.)	+251 kg (+553 lb.)	0 mm (0 in.)	+12 mm (+0.47 in.)	+16 mm (+0.62 in.)

*May change based on vehicle configuration, weight, or tire-pressure adjustments.

[§]Requires 8-deg. rear axle stops.

Bucket Selection Guides

LOOSE MATERIALS	kg/m ³	lb./cu. yd.	LOOSE MATERIALS	kg/m ³	lb./cu. yd.
Chips, pulpwood	288	486	Limestone, coarse, sized	1570	2,646
Cinders (coal, ashes, clinkers)	673	1,134	Limestone, mixed sizes	1682	2,835
Clay and gravel, dry	1602	2,700	Limestone, pulverized or crushed	1362	2,295
Clay, compact, solid	1746	2,943	Sand, damp	2083	3,510
Clay, dry in lump loose	1009	1,701	Sand, dry	1762	2,970
Clay, excavated in water	1282	2,160	Sand, voids, full of water	2083	3,510
Coal, anthracite, broken, loose	865	1,458	Sandstone, quarried	1314	2,214
Coal, bituminous, moderately wet	801	1,350	Shale, broken crushed	1362	2,295
Earth, common loam, dry	1218	2,052	Slag, furnace granulated	1955	3,294
Earth, mud, packed	1843	3,105	Stone or gravel, 37.5 to 87.5-mm (1.5 to 3.5 in.) size	1442	2,430
Granite, broken	1538	2,592	Stone or gravel, 18.75-mm (0.75 in.) size	1602	2,700
Gypsum	2275	3,834			

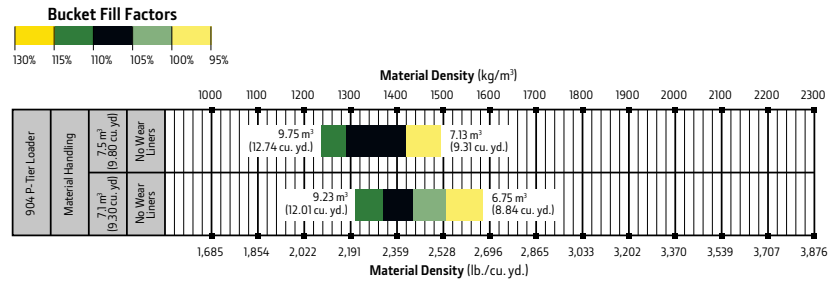

Additional equipment

Key: ● Standard ▲ Optional or special

See your John Deere dealer for further information.

904 P Engine

- Wet-sleeve cylinder liners
- Programmable auto-idle and auto shutdown
- Selected idle adjustment from 900–1,250 rpm
- Starter excessive-cranking protection
- Automatic engine cool-down timer
- Automatic derating for exceeded system temperatures
- Serpentine drive belt for automatic tensioner
- Electrical fuel-priming pump
- Dual-stage fuel filter and water separator
- 500-hour vertical spin-on oil filter
- Engine-compartment light
- ▲ Chrome exhaust stack
- ▲ Automatic ether starting aid and engine block heater (recommended for cold starts below –12 deg. C [10 deg. F])
- Centrifugal engine air pre-cleaner
- ▲ Throttle lock

Powertrain

- Clutch cutoff with 4 operator settings: Automatic, level ground, small slope, or steep slope
- Programmable maximum high gear
- Clutch calibration engaged from monitor
- 2,000-hour vertical spin-on transmission filter
- Transmission fill tube with sight gauge
- Transmission diagnostic ports
- 5-speed transmission with lockup torque converter
- Brake adjusters and retractors
- Axle oil temperature sensing
- Wheel-spin control

904 P Quad-Cool™ Cooling System

- Heavy-duty, trash-resistant radiator and high-ambient cooling package
- 2-side access to all coolers
- Isolated from engine compartment
- Engine radiator
- Integral engine oil cooler
- Hydraulic oil cooler (oil to air)
- Transmission oil cooler (oil to air)
- Charge air cooler (air to air)
- Fuel cooler
- Coolant recovery tank with under-hood lighting
- Coolant-loss sensor
- Antifreeze, –37 deg. C (–34 deg. F)
- Cool-on-demand swing-out fan
- Enclosed fan safety guard
- Automatic reversing fan drive
- Axle and service-brake coolers

Hydraulics

- Electrohydraulic control with soft stops and adjustable settings
- In-cab adjustable automatic return-to-dig bucket positioner
- In-cab adjustable automatic boom-height kickout/return to carry
- Reservoir with sight gauge and fill strainer
- Hydraulic diagnostic ports
- 4,000-hour in-tank filter
- 2 function — 2-lever fingertip controls
- ▲ 2 function — joystick
- ▲ 2 function — joystick with F-N-R (steering wheel only)
- 2 programmable multifunction buttons
- Ride control, automatic with monitor-adjustable speed settings
- ▲ Hydra™ XR cold-temperature hydraulic fluid recommended below –25 deg. C (–13 deg. F)

904 P Steering Systems

- Joystick steering with gearshift, F-N-R, and horn
- ▲ Conventional steering wheel with spinner knob
- ▲ Secondary steering

Electrical

- Solid-state electrical power-distribution system
- Lockable master electrical-disconnect switch
- Battery-terminal safety covers
- By-pass start safety cover at starter
- Remote jump-start access in battery box
- Pre-wired for beacon/strobe light
- ▲ Beacon bracket (single or dual available)
- ▲ LED strobe beacon
- Lights: Halogen driving lights with guards (2) / Front (4), rear cab (2), and rear grille (2) work lights / LEF front turn signals and flashers / LED stop- and taillights
- ▲ Premium LED work, drive, and marker lights
- Programmable courtesy lights
- Horn, electric
- Reverse warning alarm
- Multifunction/multi-language 178-mm (7 in.) LCD color monitor includes: Digital instruments — Analog display (hydraulic oil temperature, engine coolant temperature, transmission oil temperature, and engine oil pressure) / Digital display (engine rpm, transmission gear/direction indicator, hour meter, fuel level, diesel exhaust fluid [DEF] level, speedometer, odometer, and average fuel consumption)
- Integrated cycle counter with 5 categories
- Indicator lights: Standard and selected options / Amber caution and red stop
- Operator-warning messages

While general information, pictures, and descriptions are provided, some illustrations and text may include product options and accessories NOT AVAILABLE in all regions, and in some countries products and accessories may require modifications or additions to ensure compliance with the local regulations of those countries.

Net engine power is with standard equipment including air cleaner, exhaust system, alternator, and cooling fan at test conditions per ISO 9249. No derating is required up to 3050-m (10,000 ft.) altitude. Specifications and design subject to change without notice. Specifications with the exception of bucket capacity are in accordance with all applicable ISO standards. Except where otherwise noted, these specifications are based on a unit with applicable linkage and standard equipment, ROPS cab, rear cast bumper/counterweight, transmission side-frame guards, bottom guards, standard tires, full fuel tank, and 79-kg (175 lb.) operator.

Additional equipment *(continued)*

Key: ● Standard ▲ Optional or special

See your John Deere dealer for further information.

904 P Electrical *(continued)*

- Built-in diagnostics: Diagnostic-code details / Sensor values / Calibrations / Individual circuit tester
- ▲ Electrical corrosion-prevention package
- Premium AM/FM/Weather Band (WB) radio with Bluetooth®, remote auxiliary port, and remote USB port
- ▲ 24- to 12-volt, 30-amp converter with 3 in-cab power ports

Operator's Station

- Quiet Cab with air conditioning/heater (ROPS/FOPS Level 2, isolation mounted)
- Automatic temperature control
- Rear window defrost vent
- Keyless start with multiple security modes
- Sealed-switch module with function indicators
- Premium seat with high-wide back and headrest extension, heated and ventilated, leather/fabric cover, pan tilt/extend, damper adjustments, and adjustable heavy-duty air suspension
- Hydraulic controls and joystick steering integrated to seat
- High-visibility, bright-orange seat belt, 76 mm (3 in.), with retractor
- Seat-belt minder monitoring with JDLink™
- ▲ Seat-belt indicator beacon light
- Cup holder and cup/thermos holder with retaining strap
- Lunch-box/cooler holder with tie-down brackets
- LED dome and reading light
- Coat hook
- Rubber floor mat
- ▲ Dual-tilt steering column (steering wheel only)

904 P Operator's Station *(continued)*

- Operator's manual storage compartment
- Outside (2) and inside (2) rearview mirrors
- ▲ In-cab adjustable heated outside mirrors with convex lens
- Left-side operator-station access
- Front window-washing platforms with fall-arrest system anchor points tested to 2268 kg (5,000 lb.)
- Slip-resistant steps and ergonomic handholds
- Pull-down front sun visor
- ▲ Pull-down rear sun visor
- CB radio ready with 12-volt power, bracket, and antennae included
- Front and rear intermittent windshield wiper and washers
- ▲ Powered cab air pre-cleaner
- Rearview camera
- ▲ Advanced rear object-detection system
- ▲ Advanced vision system
- Payload scale ready
- ▲ SmartWeigh™ ready + trial
- ▲ SmartWeigh
- ▲ Fire extinguisher

Loader Linkage

- Z-Bar loader linkage

Buckets and Attachments

- ▲ Full line of Deere pin-on buckets
- Bushed pin joints (including static joints) on optional Enhanced-Performance buckets

Overall Vehicle

- JDLink wireless communication system (available in specific countries; see your dealer for details)
- ▲ Auto-lube system with empty reservoir sensor and diagnostics integrated into machine diagnostics and JDLink alerts
- Front, mid, and rear tie-downs

904 P Overall Vehicle *(continued)*

- Rear cast bumper with rear hitch and locking pin
- Articulation locking bar
- 40-deg. steering articulation to each side with rubber-cushion stops on frame
- Vandal protection with lockable engine enclosures, right counterweight storage, battery box, and filler access for radiator/fuel/hydraulic transmission
- Right and left handrails, platforms, and steps
- Service steps and handholds
- Storage compartment
- Fuel-tank fill strainer
- Heavy-duty fuel-tank guard
- Ground-level fueling and DEF
- Same-side ground-level daily servicing
- Environmental drains for engine, transmission, hydraulic oils, and engine coolant
- Fluid-sampling ports for engine, transmission, hydraulic and axle oils, and engine coolant
- 875/65R29 tires on 5-piece rims
- ▲ Tire-pressure monitoring system
- Level 1 sound package
- Level 2 sound package
- Transmission side-frame and bottom guards
- ▲ Fast-fuel system
- ▲ Quick fluid service (engine, transmission, hydraulic oils, and engine coolant)
- Fenders, full-coverage, front
- ▲ Fenders, full-coverage, front and rear
- ▲ Fenders, roading, full-coverage, front and rear
- Lift eyes
- ▲ Wheel-chock-mounting brackets
- ▲ License-plate bracket and light

While general information, pictures, and descriptions are provided, some illustrations and text may include product options and accessories NOT AVAILABLE in all regions, and in some countries products and accessories may require modifications or additions to ensure compliance with the local regulations of those countries.

Net engine power is with standard equipment including air cleaner, exhaust system, alternator, and cooling fan at test conditions per ISO 9249. No derating is required up to 3050-m (10,000 ft.) altitude. Specifications and design subject to change without notice. Specifications with the exception of bucket capacity are in accordance with all applicable ISO standards. Except where otherwise noted, these specifications are based on a unit with applicable linkage and standard equipment, ROPS cab, rear cast bumper/counterweight, transmission side-frame guards, bottom guards, standard tires, full fuel tank, and 79-kg (175 lb.) operator.



MW904PAU (23-03)



JOHN DEERE