

824 P

Wheel Loader



JOHN DEERE





PRIMED FOR PRODUCTIVITY



SEE IT LIKE NEVER BEFORE

New Advanced Vision System includes two digital cameras mounted on the rearview-mirror platforms that integrate with the rearview camera for a single display on a dedicated in-cab monitor. Overlaid within the monitor's rear-camera view, dynamic reversal projected-path lines help operators visualize the loader's anticipated reversal path based on its articulation, for sight lines to people or objects directly within the path.

LARGE AND IN CHARGE

READY TO DO THE HEAVY LIFTING.

Combining serious performance with fuel efficiency, customer-inspired components, and intuitive controls, our 824 P-Tier provides the muscle operators need to work productively and comfortably. Enhancements include increased horsepower, an ergonomically reimagined cab, and simplified service points. With its rugged EPA Final Tier 4/EU Stage V-compliant JD9 diesel, high-capacity heavy-duty axles, and a wealth of proven options, this large-scale wheel loader is built rock solid for the long haul.

Step up your game

With standard advantages such as an updated JD9 engine and after-treatment, a fuel-efficient lockup torque converter, and a dedicated steering pump, the 824 P-Tier can heap heavier and haul more.

Outsized comfort

Cab boasts three more inches of legroom than previous models. Standard premium heated/ventilated seat, updated HVAC system with automatic temperature control, and redesigned sealed-switch module are placed for ergonomic comfort and convenience. A 79-percent-wider door than on previous series models makes getting in and out easier.

It's easy to take control

Easier and more intuitive to operate than the controls on previous models, seat-mounted right-hand hydraulic controls feature two programmable multifunction buttons with electro-hydraulic (EH) controls.

Material matters

SmartWeigh option features dynamic weighing technology that allows operators to weigh without interrupting workflow and removes the need to lower and reraise the boom after tipoff. Shared through the onboard monitor, SmartWeigh is easy to calibrate and effortlessly integrates with JDLink™ so you can track and visualize payload data from almost anywhere. Available as a factory-installed or field-kit option, you can also try SmartWeigh at a low cost for 250 machine hours.

Precision Construction

From grade management and obstacle detection to product automation features and jobsite intelligence, this suite of construction technology delivers productivity solutions to help you get more done, more efficiently.

John Deere construction equipment comes with in-base connectivity — free from subscriptions or annual renewals. Analyze critical machine data, track utilization, review diagnostic alerts, and more from **the John Deere Operations Center™**. The Operations Center also enables **John Deere Connected Support™**, which uses data from thousands of connected machines to proactively address issues before they arise. Your dealer can also remotely monitor machine health, diagnose problems, and even update machine software without a trip to the jobsite.*

*Availability varies by region and product. Options not available in every country.



SMARTWEIGH™
PAYLOAD-WEIGHING SOLUTION
IS DEERE DESIGNED & SUPPORTED





***OPTIONAL AUTO-LUBE SYSTEM
SAVES TIME & HASSLE***



824 P

WHEEL LOADER

YOU THOUGHT OF EVERYTHING IT'S IN THE DETAILS.

Your best ideas have helped our large wheel loaders stand out on the jobsite and in the industry. These are just some of the purpose-built details that add up to push our 824 P-Tier – and your operation – to the next level.



Make the shift

Smooth-shifting transmission delivers impressive acceleration and cycle times. Design optimizes power and fuel efficiency during transport, roading, and ramp climbing.



Heavy-duty durability

Large, high-capacity, heavy-duty axles with standard axle cooling and filtration increase durability in demanding conditions compared to previous models.



Reliable redesign

Routing of the electrical and hydraulic systems has been significantly simplified to minimize friction, improving reliability and easing maintenance.



Buckle up

A seat-belt minder sends an alert to JDLink if the safety belt isn't latched within 30 seconds after the parking brake is released.



On the winning side

All daily service points including fuel are conveniently grouped on the left side of the machine for easy reach. Easier access to the engine oil dipstick cuts routine service time in half.



Keep your cool

Quad-Cool™ system design places coolers in a unique boxed configuration that's isolated from engine heat, for increased efficiency and durability. Optional hydraulic reversing fan automatically reverses at predetermined intervals, or can be programmed through the monitor, to eject debris from the cooler cores.



While general information, pictures, and descriptions are provided, some illustrations and text may include product options and accessories NOT AVAILABLE in all regions, and in some countries products and accessories may require modifications or additions to ensure compliance with the local regulations of those countries.

Engine		824 P-TIER		
Manufacturer and Model	JD9 PSS 6090	JD9 6090		
Non-Road Emission Standard	EPA Final Tier 4/EU Stage V	EPA Tier 3/EU Stage IIIA		
Cylinders	6	6		
Valves per Cylinder	4	4		
Displacement	9.0 L (548 cu. in.)	9.0 L (548 cu. in.)		
Net Peak Power (ISO 9249)	256 kW (343 hp) at 1,600 rpm	256 kW (343 hp) at 1,600 rpm		
Net Peak Torque (ISO 9249)	1627 Nm (1,200 lb.-ft.) at 1,300 rpm	1627 Nm (1,200 lb.-ft.) at 1,300 rpm		
Net Torque Rise	57%	55%		
Fuel System	High-pressure common rail	High-pressure common rail		
Lubrication	Full-flow spin-on filter and integral cooler	Full-flow spin-on filter and integral cooler		
Aspiration	Series turbocharged, charge air cooled	Turbocharged, charge air cooled		
Air Cleaner	Under-hood, dual-element dry type, restriction indicator in cab monitor for service			
Cooling				
Fan Drive	Hydraulically driven, proportionally controlled, fan aft of coolers			
Electrical				
Electrical System	24 volt with 150-amp alternator			
Batteries (2 – 12 volt)	1,400 CCA (each)			
Transmission System				
Type	Countershaft-type PowerShift™ with lockup torque converter			
Torque Converter	Single stage, dual phase with freewheeling stator with lockup clutch			
Shift Control	Electronically modulated, adaptive, load and speed dependent			
Operator Interface	Steering-column or joystick-mounted F-N-R and gear-select lever; Quick-Shift button on hydraulic lever			
Shift Modes	Manual/auto (1st–5th or 2nd–5th); Quick-Shift button with 2 selectable modes: kick-down or kick-up/down; and 4 settings for clutch cutoff			
Maximum Travel Speeds (with 26.5 R 25, 1 Star L3 tires)	<i>Standard 5-Speed With Lockup Torque Converter</i>			
	<i>Forward</i>	<i>Reverse</i>	<i>Forward</i>	<i>Reverse</i>
Range 1	7.1 km/h (4.4 mph)	7.1 km/h (4.4 mph)	7.1 km/h (4.4 mph)	7.1 km/h (4.4 mph)
Range 2	13.3 km/h (8.3 mph)	13.3 km/h (8.3 mph)	12.8 km/h (8.0 mph)	12.8 km/h (8.0 mph)
Range 3	20.3 km/h (12.6 mph)	29.0 km/h (18.0 mph)	19.6 km/h (12.2 mph)	28.0 km/h (17.4 mph)
Range 4	29.0 km/h (18.0 mph)	N/A	28.0 km/h (17.4 mph)	N/A
Range 5	40.0 km/h (24.9 mph)	N/A	40.0 mph (24.9 km/h)	N/A
Axles/Brakes				
Final Drives	Heavy-duty inboard-mounted planetary			
Differentials	Hydraulic locking front with conventional rear – standard; dual locking front and rear – optional			
Rear Axle Oscillation, Stop to Stop (with 26.5 R 25, 1 Star L3 tires)	26 deg. (13 deg. each direction)			
Brakes (conform to ISO 3450)				
Service	Hydraulically actuated, spring released, inboard, sun-gear mounted, pressure oil cooled, self-adjusting, single disc			
Parking	Automatic spring applied, hydraulically released, oil cooled, multi disc			
Tires/Wheels (see page 12 for complete tire adjustments)				
	<i>Tread Width</i>	<i>Width Over Tires</i>		
Michelin 26.5 R 25, 1 Star L3	2298 mm (90.5 in.)	3084 mm (121.4 in.)		
Serviceability				
Refill Capacities	<i>EPA FT4/EU Stage V</i>	<i>EPA Tier 3/EU Stage IIIA</i>		
Fuel Tank With Lockable Cap	477 L (126 gal.)	477 L (126 gal.)		
Diesel Exhaust Fluid (DEF) (EPA FT4/EU Stage V only)	26.3 L (6.9 gal.)	N/A		
Cooling System	48 L (50.7 qt.)	48 L (50.7 qt.)		
Engine Oil With Vertical Spin-On Filter	34 L (36 qt.)	34 L (36 qt.)		
Transmission Reservoir With Vertical Filter	28 L (29.5 qt.)	28 L (29.5 qt.)		
Axle Oil (front and rear, each)	55.3 L (58.4 qt.)	55.3 L (58.4 qt.)		
Hydraulic Reservoir and Filter	142 L (37.5 gal.)	151 L (39.9 gal.)		
Park Brake Oil (wet disc)	0.7 L (24 oz.)	0.7 L (24 oz.)		

824 P-TIER WHEEL LOADER SPECIFICATIONS

P

While general information, pictures, and descriptions are provided, some illustrations and text may include product options and accessories NOT AVAILABLE in all regions, and in some countries products and accessories may require modifications or additions to ensure compliance with the local regulations of those countries.

Hydraulic System/Steering		824 P-TIER
Loader Pumps	2 variable-displacement, load-sensing axial-piston pumps; closed-center system	
Maximum Rated Flow at 6895 kPa (1,000 psi) and 2,250 rpm	484.5 L/m (128 gpm)	
System Relief Pressure (loader and steering)	24 900 kPa (3,610 psi)	
Steering Pump	1 variable-displacement, load-sensing axial-piston pump; closed-center system	
Maximum Rated Flow at 6895 kPa (1,000 psi) and 2,250 rpm	161.5 L/m (43 gpm)	
System Relief Pressure (loader and steering)	24 900 kPa (3,610 psi)	
Loader Controls	2-function valve; single- or dual-lever controls; control lever lockout feature; optional 3rd- and 4th-function valve with auxiliary levers	
Steering (conforms to ISO 5010)		
Type	Power, fully hydraulic	
Articulation Angle	80-deg. arc (40 deg. each direction)	
Turning Radius (measured to centerline of outside tire)	5.92 m (19 ft. 5 in.)	
Hydraulic Cycle Times <i>Standard-Lift</i>		
Raise	5.9 sec.	
Dump	1.3 sec.	
Lower (float down)	2.5 sec.	
Total	9.7 sec.	
Dimensions and Specifications With Pin-On Bucket		

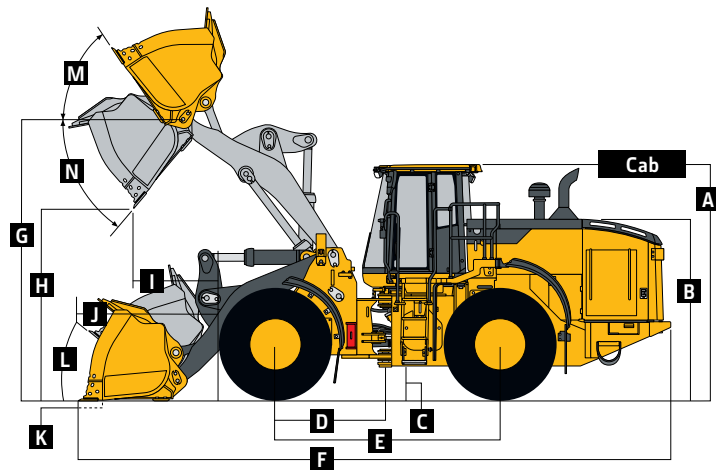

824 P-TIER STANDARD-LIFT AND HIGH-LIFT LOADERS WITH PIN-ON BUCKET

	Standard-Lift	Standard-Lift	Standard-Lift	Standard-Lift	Standard-Lift	Standard-Lift	Standard-Lift	Standard-Lift	High-Lift	High-Lift
	4.7 m ³ (6.1 cu. yd.)			4.8-m ³ (6.25 cu. yd.) enhanced performance			5.2-m ³ (6.75 cu. yd.) enhanced performance		4.7 m ³ (6.1 cu. yd.)	
Dimensions With Bucket	<i>teeth and segments</i>			<i>teeth and segments</i>			<i>teeth and segments</i>		<i>teeth and segments</i>	
Cutting Edge Type	<i>bolt-on edge</i>	<i>JAGZ™</i>	<i>JAGZ™</i>	<i>bolt-on edge</i>	<i>JAGZ™</i>	<i>JAGZ™</i>	<i>bolt-on edge</i>	<i>JAGZ™</i>	<i>bolt-on edge</i>	<i>teeth and segments</i>
A Height to Top of Cab	3.57 m (11 ft. 9 in.)	3.57 m (11 ft. 9 in.)	3.57 m (11 ft. 9 in.)	3.57 m (11 ft. 9 in.)	3.57 m (11 ft. 9 in.)	3.57 m (11 ft. 9 in.)	3.57 m (11 ft. 9 in.)	3.57 m (11 ft. 9 in.)	3.57 m (11 ft. 9 in.)	3.57 m (11 ft. 9 in.)
B Hood Height	2.73 m (8 ft. 11 in.)	2.73 m (8 ft. 11 in.)	2.73 m (8 ft. 11 in.)	2.73 m (8 ft. 11 in.)	2.73 m (8 ft. 11 in.)	2.73 m (8 ft. 11 in.)	2.73 m (8 ft. 11 in.)	2.73 m (8 ft. 11 in.)	2.73 m (8 ft. 11 in.)	2.73 m (8 ft. 11 in.)
C Ground Clearance	458 mm (18 in.)	458 mm (18 in.)	458 mm (18 in.)	458 mm (18 in.)	458 mm (18 in.)	458 mm (18 in.)	458 mm (18 in.)	458 mm (18 in.)	458 mm (18 in.)	458 mm (18 in.)
D Length From Centerline to Front Axle	1.70 m (5 ft. 7 in.)	1.70 m (5 ft. 7 in.)	1.70 m (5 ft. 7 in.)	1.70 m (5 ft. 7 in.)	1.70 m (5 ft. 7 in.)	1.70 m (5 ft. 7 in.)	1.70 m (5 ft. 7 in.)	1.70 m (5 ft. 7 in.)	1.70 m (5 ft. 7 in.)	1.70 m (5 ft. 7 in.)
E Wheelbase	3.46 m (11 ft. 4 in.)	3.46 m (11 ft. 4 in.)	3.46 m (11 ft. 4 in.)	3.46 m (11 ft. 4 in.)	3.46 m (11 ft. 4 in.)	3.46 m (11 ft. 4 in.)	3.46 m (11 ft. 4 in.)	3.46 m (11 ft. 4 in.)	3.46 m (11 ft. 4 in.)	3.46 m (11 ft. 4 in.)
F Overall Length, Bucket on Ground	9.28 m (30 ft. 5 in.)	9.49 m (31 ft. 2 in.)	9.28 m (30 ft. 5 in.)	9.38 m (30 ft. 9 in.)	9.59 m (31 ft. 6 in.)	9.37 m (30 ft. 9 in.)	9.44 m (31 ft. 0 in.)	9.44 m (31 ft. 0 in.)	9.78 m (32 ft. 1 in.)	9.99 m (32 ft. 9 in.)
G Height to Hinge Pin, Fully Raised	4.48 m (14 ft. 9 in.)	4.48 m (14 ft. 9 in.)	4.48 m (14 ft. 9 in.)	4.48 m (14 ft. 9 in.)	4.48 m (14 ft. 9 in.)	4.48 m (14 ft. 9 in.)	4.48 m (14 ft. 9 in.)	4.48 m (14 ft. 9 in.)	4.85 m (15 ft. 11 in.)	4.85 m (15 ft. 11 in.)
H Dump Clearance, 45 deg., Full Height	3.19 m (10 ft. 6 in.)	3.06 m (10 ft. 0 in.)	3.20 m (10 ft. 6 in.)	3.12 m (10 ft. 3 in.)	2.98 m (9 ft. 9 in.)	3.13 m (10 ft. 3 in.)	3.08 m (10 ft. 1 in.)	3.08 m (10 ft. 1 in.)	3.64 m (11 ft. 11 in.)	3.51 m (11 ft. 6 in.)
I Reach, 45-deg. Dump, Full Height	1.28 m (4 ft. 2 in.)	1.42 m (4 ft. 8 in.)	1.28 m (4 ft. 2 in.)	1.33 m (4 ft. 4 in.)	1.47 m (4 ft. 10 in.)	1.33 m (4 ft. 4 in.)	1.38 m (4 ft. 6 in.)	1.38 m (4 ft. 6 in.)	1.64 m (5 ft. 5 in.)	1.79 m (5 ft. 10 in.)
J Reach, 45-deg. Dump, 2.13-m (7 ft. 0 in.) Clearance	2.05 m (6 ft. 9 in.)	2.12 m (6 ft. 11 in.)	2.05 m (6 ft. 9 in.)	2.08 m (6 ft. 10 in.)	2.15 m (7 ft. 1 in.)	2.09 m (6 ft. 10 in.)	2.11 m (6 ft. 11 in.)	2.11 m (6 ft. 11 in.)	2.50 m (8 ft. 2 in.)	2.58 m (8 ft. 5 in.)
K Maximum Digging Depth	116 mm (4.6 in.)	135 mm (5.3 in.)	112 mm (4.4 in.)	123 mm (4.8 in.)	143 mm (5.6 in.)	119 mm (4.7 in.)	129 mm (5.1 in.)	129 mm (5.0 in.)	229 mm (9.0 in.)	249 mm (9.8 in.)
L Maximum Rollback at Ground Level	45.4 deg.	45.4 deg.	45.4 deg.	45.4 deg.	45.4 deg.	45.4 deg.	45.4 deg.	45.4 deg.	41.5 deg.	41.5 deg.
M Maximum Rollback, Boom Fully Raised	52.0 deg.	52.0 deg.	52.0 deg.	52.0 deg.	52.0 deg.	52.0 deg.	52.0 deg.	52.0 deg.	53.1 deg.	53.1 deg.
N Maximum Bucket Dump Angle, Fully Raised	44.3 deg.	44.3 deg.	44.3 deg.	44.8 deg.	44.8 deg.	44.8 deg.	44.8 deg.	44.8 deg.	40.0 deg.	40.0 deg.
Loader Clearance Circle, Bucket Carry Position	14.14 m (46 ft. 5 in.)	14.26 m (46 ft. 9 in.)	14.13 m (46 ft. 4 in.)	14.20 m (46 ft. 7 in.)	14.34 m (47 ft. 1 in.)	14.20 m (46 ft. 7 in.)	14.24 m (46 ft. 9 in.)	14.24 m (46 ft. 9 in.)	14.27 m (46 ft. 10 in.)	14.35 m (47 ft. 1 in.)

824 P-TIER

While general information, pictures, and descriptions are provided, some illustrations and text may include product options and accessories NOT AVAILABLE in all regions, and in some countries products and accessories may require modifications or additions to ensure compliance with the local regulations of those countries.

Dimensions and Specifications											
With Pin-On Bucket (continued)											
824 P-TIER											
	Standard-Lift	Standard-Lift	Standard-Lift	Standard-Lift	Standard-Lift	Standard-Lift	Standard-Lift	Standard-Lift	High-Lift	High-Lift	
Specifications With Bucket	4.7 m ³ (6.1 cu. yd.)			4.8-m ³ (6.25 cu. yd.) enhanced performance			5.2-m ³ (6.75 cu. yd.) material-handling enhanced performance			4.7 m ³ (6.1 cu. yd.)	
Cutting Edge Type	bolt-on teeth and edge segments JAGZ™			bolt-on teeth and edge segments JAGZ			bolt-on edge segments JAGZ			bolt-on teeth and edge segments JAGZ	
Capacity, Heaped	4.7 m ³ (6.1 cu. yd.)	4.7 m ³ (6.1 cu. yd.)	4.7 m ³ (6.1 cu. yd.)	4.8 m ³ (6.25 cu. yd.)	4.8 m ³ (6.25 cu. yd.)	4.8 m ³ (6.25 cu. yd.)	5.2 m ³ (6.75 cu. yd.)	5.2 m ³ (6.75 cu. yd.)	4.7 m ³ (6.1 cu. yd.)	4.7 m ³ (6.1 cu. yd.)	
Capacity, Heaped at 110% Fill Factor	5.1 m ³ (6.7 cu. yd.)	5.1 m ³ (6.7 cu. yd.)	5.1 m ³ (6.7 cu. yd.)	5.3 m ³ (6.88 cu. yd.)	5.3 m ³ (6.88 cu. yd.)	5.3 m ³ (6.88 cu. yd.)	5.7 m ³ (7.43 cu. yd.)	5.7 m ³ (7.43 cu. yd.)	5.1 m ³ (6.7 cu. yd.)	5.1 m ³ (6.7 cu. yd.)	
Capacity, Struck	4.0 m ³ (5.3 cu. yd.)	4.0 m ³ (5.3 cu. yd.)	4.0 m ³ (5.3 cu. yd.)	4.1 m ³ (5.36 cu. yd.)	4.1 m ³ (5.36 cu. yd.)	4.1 m ³ (5.36 cu. yd.)	4.4 m ³ (5.8 cu. yd.)	4.4 m ³ (5.8 cu. yd.)	4.0 m ³ (5.3 cu. yd.)	4.0 m ³ (5.3 cu. yd.)	
Bucket Weight With Bolt-On Cutting Edge	2437 kg (5,373 lb.)	2561 kg (5,646 lb.)	2460 kg (5,423 lb.)	2464 kg (5,432 lb.)	2587 kg (5,703 lb.)	2486 kg (5,481 lb.)	2505 kg (5,523 lb.)	2527 kg (5,571 lb.)	2437 kg (5,373 lb.)	2561 kg (5,646 lb.)	
Bucket Width	3.28 m (10 ft. 9 in.)	3.31 m (10 ft. 10 in.)	3.28 m (10 ft. 9 in.)	3.28 m (10 ft. 9 in.)	3.31 m (10 ft. 10 in.)	3.28 m (10 ft. 9 in.)	3.28 m (10 ft. 9 in.)	3.28 m (10 ft. 9 in.)	3.28 m (10 ft. 9 in.)	3.28 m (10 ft. 9 in.)	
Breakout Force	18 878 kg (41,619 lb.)	16 636 kg (36,676 lb.)	18 905 kg (41,678 lb.)	17 776 kg (39,189 lb.)	15 755 kg (34,734 lb.)	17 798 kg (39,238 lb.)	17 054 kg (37,598 lb.)	17 077 kg (37,648 lb.)	17 695 kg (39,011 lb.)	15 591 kg (34,372 lb.)	
Tipping Load, Straight, No Tire Deflection											
EPA FT4/EU Stage V	21 056 kg (46,420 lb.)	20 890 kg (46,055 lb.)	21 028 kg (46,359 lb.)	20 786 kg (45,825 lb.)	20 618 kg (45,455 lb.)	20 757 kg (45,761 lb.)	20 623 kg (45,466 lb.)	20 597 kg (45,409 lb.)	17 809 kg (39,262 lb.)	17 649 kg (38,909 lb.)	
EPA Tier 3/EU Stage IIIA	20 585 kg (45,382 lb.)	20 418 kg (45,014 lb.)	20 557 kg (45,320 lb.)	20 319 kg (44,796 lb.)	20 151 kg (44,425 lb.)	20 291 kg (44,734 lb.)	20 159 kg (44,443 lb.)	20 133 kg (44,386 lb.)	17 398 kg (38,356 lb.)	17 238 kg (38,003 lb.)	
Tipping Load, Straight, With Tire Deflection											
EPA FT4/EU Stage V	19 659 kg (43,341 lb.)	19 494 kg (42,977 lb.)	19 632 kg (43,281 lb.)	19 413 kg (42,798 lb.)	19 248 kg (42,435 lb.)	19 386 kg (42,739 lb.)	19 254 kg (42,448 lb.)	19 227 kg (42,388 lb.)	18 099 kg (39,901 lb.)	17 898 kg (39,458 lb.)	
EPA Tier 3/EU Stage IIIA	19 233 kg (42,401 lb.)	19 068 kg (42,038 lb.)	19 206 kg (42,342 lb.)	18 993 kg (41,872 lb.)	18 825 kg (41,502 lb.)	18 963 kg (41,806 lb.)	18 834 kg (41,522 lb.)	18 807 kg (41,462 lb.)	17 694 kg (39,009 lb.)	17 493 kg (38,565 lb.)	
Tipping Load, 37-deg. Partial Turn											
EPA FT4/EU Stage V	18 525 kg (40,841 lb.)	18 359 kg (40,475 lb.)	18 497 kg (40,779 lb.)	18 281 kg (40,303 lb.)	18 113 kg (39,932 lb.)	18 252 kg (40,239 lb.)	18 131 kg (39,972 lb.)	18 105 kg (39,915 lb.)	15 603 kg (34,399 lb.)	15 443 kg (34,046 lb.)	
EPA Tier 3/EU Stage IIIA	18 105 kg (39,915 lb.)	17 938 kg (39,546 lb.)	18 077 kg (39,853 lb.)	17 865 kg (39,386 lb.)	17 697 kg (39,015 lb.)	17 836 kg (39,322 lb.)	17 717 kg (39,059 lb.)	17 691 kg (39,002 lb.)	15 237 kg (33,592 lb.)	15 077 kg (33,239 lb.)	
Tipping Load, 40-deg. Full Turn, No Tire Deflection											
EPA FT4/EU Stage V	18 116 kg (39,939 lb.)	17 949 kg (39,571 lb.)	18 088 kg (39,877 lb.)	17 875 kg (39,408 lb.)	17 708 kg (39,039 lb.)	17 847 kg (39,346 lb.)	17 728 kg (39,084 lb.)	17 702 kg (39,026 lb.)	15 246 kg (33,612 lb.)	15 086 kg (33,259 lb.)	
EPA Tier 3/EU Stage IIIA	17 704 kg (39,031 lb.)	17 537 kg (38,662 lb.)	17 676 kg (38,969 lb.)	17 467 kg (38,508 lb.)	17 300 kg (38,140 lb.)	17 439 kg (38,446 lb.)	17 322 kg (38,188 lb.)	17 296 kg (38,131 lb.)	14 887 kg (32,820 lb.)	14 727 kg (32,467 lb.)	
Tipping Load, 40-deg. Full Turn, With Tire Deflection											
EPA FT4/EU Stage V	16 293 kg (35,920 lb.)	16 131 kg (35,563 lb.)	16 266 kg (35,860 lb.)	16 083 kg (35,457 lb.)	15 918 kg (35,093 lb.)	16 056 kg (35,397 lb.)	15 939 kg (35,139 lb.)	15 912 kg (35,080 lb.)	15 126 kg (33,347 lb.)	14 925 kg (32,904 lb.)	
EPA Tier 3/EU Stage IIIA	15 945 kg (35,153 lb.)	15 783 kg (34,796 lb.)	15 918 kg (35,093 lb.)	15 738 kg (34,696 lb.)	15 573 kg (34,333 lb.)	15 711 kg (34,637 lb.)	15 594 kg (34,379 lb.)	15 570 kg (34,326 lb.)	14 784 kg (32,593 lb.)	14 586 kg (32,157 lb.)	
Rated Operating Load, 50% Full-Turn Tipping Load, With Tire Deflection (conforms to ISO 14397-1)*											
EPA FT4/EU Stage V	8147 kg (17,961 lb.)	8066 kg (17,782 lb.)	8133 kg (17,930 lb.)	8042 kg (17,730 lb.)	7959 kg (17,547 lb.)	8028 kg (17,699 lb.)	7970 kg (17,571 lb.)	7956 kg (17,540 lb.)	7563 kg (16,674 lb.)	7463 kg (16,453 lb.)	
EPA Tier 3/EU Stage IIIA	7973 kg (17,577 lb.)	7892 kg (17,399 lb.)	7959 kg (17,547 lb.)	7869 kg (17,348 lb.)	7787 kg (17,167 lb.)	7856 kg (17,319 lb.)	7797 kg (17,189 lb.)	7785 kg (17,163 lb.)	7392 kg (16,297 lb.)	7293 kg (16,078 lb.)	
Operating Weight											
EPA FT4/EU Stage V	26 460 kg (58,334 lb.)	26 584 kg (58,608 lb.)	26 483 kg (58,385 lb.)	26 487 kg (58,394 lb.)	26 610 kg (58,665 lb.)	26 509 kg (58,442 lb.)	26 528 kg (58,484 lb.)	26 550 kg (58,533 lb.)	26 840 kg (59,172 lb.)	26 963 kg (59,443 lb.)	
EPA Tier 3/EU Stage IIIA	26 163 kg (57,679 lb.)	26 287 kg (57,953 lb.)	26 186 kg (57,730 lb.)	26 189 kg (57,737 lb.)	26 313 kg (58,010 lb.)	26 212 kg (57,787 lb.)	26 230 kg (57,827 lb.)	26 253 kg (57,878 lb.)	26 542 kg (58,515 lb.)	26 666 kg (58,788 lb.)	

Loader operating information is based on machine with identified linkage and standard equipment, JD9 PSS 6090 (EPA Final Tier 4/EU Stage VI) engine, ROPS cab, rear cast bumper/counterweight, transmission side-frame guards, bottom guards, standard tires, full fuel tank, and 79-kg (175 lb.) operator. This information is affected by changes in tires, ballast, and different attachments.

*Rated operating capacity based on Deere attachments only.

While general information, pictures, and descriptions are provided, some illustrations and text may include product options and accessories NOT AVAILABLE in all regions, and in some countries products and accessories may require modifications or additions to ensure compliance with the local regulations of those countries.

824 P-TIER

Dimensions and Specifications

With Coupler and Hook-On Bucket

824 P-TIER

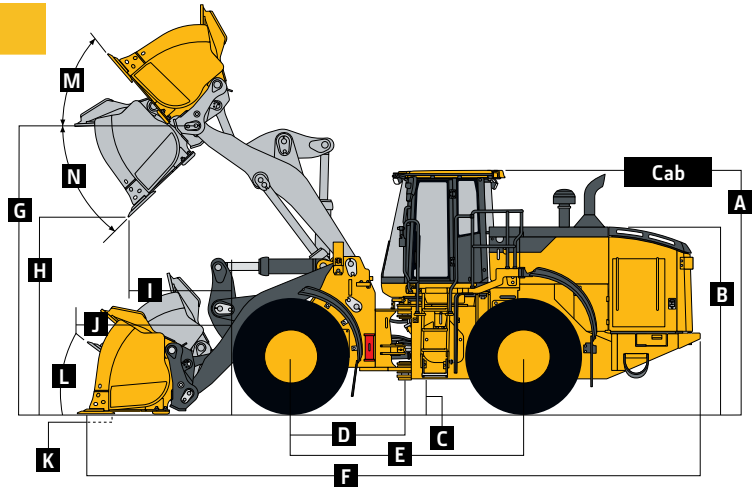

824 P-TIER STANDARD-LIFT AND HIGH-LIFT LOADERS WITH COUPLER AND HOOK-ON BUCKET

	Standard-Lift	Standard-Lift	Standard-Lift	Standard-Lift	Standard-Lift	Standard-Lift	Standard-Lift	Standard-Lift	Standard-Lift	Standard-Lift	Standard-Lift	Standard-Lift	High-Lift 4.4-m ³ (5.75 cu. yd.) enhanced performance
Dimensions With Bucket	3.8-m ³ (5.0 cu. yd.) enhanced performance			4.0-m ³ (5.25 cu. yd.) enhanced performance			4.4-m ³ (5.75 cu. yd.) enhanced performance			4.6-m ³ (6.0 cu. yd.) enhanced performance			
Cutting Edge Type	bolt-on edge	teeth and segments	JAGZ	bolt-on edge	teeth and segments	JAGZ	bolt-on edge	teeth and segments	JAGZ	bolt-on edge	teeth and segments	JAGZ	bolt-on edge
A Height to Top of Cab	3.57 m (11 ft. 9 in.)	3.57 m (11 ft. 9 in.)	3.57 m (11 ft. 9 in.)	3.57 m (11 ft. 9 in.)	3.57 m (11 ft. 9 in.)	3.57 m (11 ft. 9 in.)	3.57 m (11 ft. 9 in.)	3.57 m (11 ft. 9 in.)	3.57 m (11 ft. 9 in.)	3.57 m (11 ft. 9 in.)	3.57 m (11 ft. 9 in.)	3.57 m (11 ft. 9 in.)	3.57 m (11 ft. 9 in.)
B Hood Height	2.73 m (8 ft. 11 in.)	2.73 m (8 ft. 11 in.)	2.73 m (8 ft. 11 in.)	2.73 m (8 ft. 11 in.)	2.73 m (8 ft. 11 in.)	2.73 m (8 ft. 11 in.)	2.73 m (8 ft. 11 in.)	2.73 m (8 ft. 11 in.)	2.73 m (8 ft. 11 in.)	2.73 m (8 ft. 11 in.)	2.73 m (8 ft. 11 in.)	2.73 m (8 ft. 11 in.)	2.73 m (8 ft. 11 in.)
C Ground Clearance	458 mm (18 in.)	458 mm (18 in.)	458 mm (18 in.)	458 mm (18 in.)	458 mm (18 in.)	458 mm (18 in.)	458 mm (18 in.)	458 mm (18 in.)	458 mm (18 in.)	458 mm (18 in.)	458 mm (18 in.)	458 mm (18 in.)	458 mm (18 in.)
D Length From Centerline to Front Axle	1.70 m (5 ft. 7 in.)	1.70 m (5 ft. 7 in.)	1.70 m (5 ft. 7 in.)	1.70 m (5 ft. 7 in.)	1.70 m (5 ft. 7 in.)	1.70 m (5 ft. 7 in.)	1.70 m (5 ft. 7 in.)	1.70 m (5 ft. 7 in.)	1.70 m (5 ft. 7 in.)	1.70 m (5 ft. 7 in.)	1.70 m (5 ft. 7 in.)	1.70 m (5 ft. 7 in.)	1.70 m (5 ft. 7 in.)
E Wheelbase	3.46 m (11 ft. 4 in.)	3.46 m (11 ft. 4 in.)	3.46 m (11 ft. 4 in.)	3.46 m (11 ft. 4 in.)	3.46 m (11 ft. 4 in.)	3.46 m (11 ft. 4 in.)	3.46 m (11 ft. 4 in.)	3.46 m (11 ft. 4 in.)	3.46 m (11 ft. 4 in.)	3.46 m (11 ft. 4 in.)	3.46 m (11 ft. 4 in.)	3.46 m (11 ft. 4 in.)	3.46 m (11 ft. 4 in.)
F Overall Length, Bucket on Ground	9.30 m (30 ft. 6 in.)	9.51 m (31 ft. 3 in.)	9.30 m (30 ft. 6 in.)	9.32 m (30 ft. 7 in.)	9.53 m (31 ft. 3 in.)	9.31 m (30 ft. 7 in.)	9.41 m (30 ft. 11 in.)	9.62 m (31 ft. 7 in.)	9.40 m (30 ft. 10 in.)	9.46 m (31 ft. 1 in.)	9.67 m (31 ft. 9 in.)	9.46 m (31 ft. 1 in.)	9.91 m (32 ft. 6 in.)
G Height to Hinge Pin, Fully Raised	4.48 m (14 ft. 9 in.)	4.48 m (14 ft. 9 in.)	4.48 m (14 ft. 9 in.)	4.48 m (14 ft. 9 in.)	4.48 m (14 ft. 9 in.)	4.48 m (14 ft. 9 in.)	4.48 m (14 ft. 9 in.)	4.48 m (14 ft. 9 in.)	4.48 m (14 ft. 9 in.)	4.85 m (15 ft. 11 in.)	4.85 m (15 ft. 11 in.)	4.48 m (14 ft. 9 in.)	4.48 m (14 ft. 9 in.)
H Dump Clearance, 45 deg., Full Height	3.17 m (10 ft. 5 in.)	3.03 m (9 ft. 11 in.)	3.18 m (10 ft. 5 in.)	3.16 m (10 ft. 5 in.)	3.02 m (9 ft. 11 in.)	3.17 m (10 ft. 5 in.)	3.10 m (10 ft. 2 in.)	2.96 m (9 ft. 9 in.)	3.11 m (10 ft. 2 in.)	3.07 m (10 ft. 1 in.)	2.93 m (9 ft. 7 in.)	3.07 m (10 ft. 1 in.)	3.57 m (11 ft. 9 in.)
I Reach, 45-deg. Dump, Full Height	1.32 m (4 ft. 4 in.)	1.45 m (4 ft. 9 in.)	1.32 m (4 ft. 4 in.)	1.32 m (4 ft. 4 in.)	1.46 m (4 ft. 9 in.)	1.32 m (4 ft. 4 in.)	1.39 m (4 ft. 7 in.)	1.52 m (5 ft. 0 in.)	1.39 m (4 ft. 7 in.)	1.41 m (4 ft. 8 in.)	1.55 m (5 ft. 1 in.)	1.41 m (4 ft. 8 in.)	1.77 m (5 ft. 10 in.)
J Reach, 45-deg. Dump, 2.13-m (7 ft. 0 in.) Clearance	2.10 m (6 ft. 11 in.)	2.17 m (7 ft. 1 in.)	2.10 m (6 ft. 11 in.)	2.10 m (6 ft. 11 in.)	2.17 m (7 ft. 1 in.)	2.10 m (6 ft. 11 in.)	2.14 m (7 ft. 0 in.)	2.20 m (7 ft. 3 in.)	2.14 m (7 ft. 0 in.)	2.15 m (7 ft. 1 in.)	2.21 m (7 ft. 3 in.)	2.15 m (7 ft. 1 in.)	2.59 m (8 ft. 6 in.)
K Maximum Digging Depth	85 mm (3.3 in.)	105 mm (4.1 in.)	82 mm (3.2 in.)	90 mm (3.6 in.)	110 mm (4.3 in.)	87 mm (3.4 in.)	94 mm (3.7 in.)	114 mm (4.5 in.)	92 mm (3.6 in.)	105 mm (4.1 in.)	124 mm (4.9 in.)	101 mm (4.0 in.)	208 mm (8.2 in.)
L Maximum Rollback at Ground Level	45.4 deg.	45.4 deg.	45.4 deg.	45.4 deg.	45.4 deg.	45.4 deg.	45.4 deg.	45.4 deg.	45.4 deg.	45.4 deg.	45.4 deg.	45.4 deg.	45.4 deg.
M Maximum Rollback, Boom Fully Raised	52.0 deg.	52.0 deg.	52.0 deg.	52.0 deg.	52.0 deg.	52.0 deg.	52.0 deg.	52.0 deg.	52.0 deg.	52.0 deg.	52.0 deg.	52.0 deg.	52.0 deg.
N Maximum Bucket Dump Angle, Fully Raised	44.0 deg.	44.0 deg.	44.0 deg.	44.0 deg.	44.0 deg.	44.0 deg.	44.0 deg.	44.0 deg.	44.0 deg.	44.0 deg.	44.0 deg.	44.0 deg.	44.0 deg.
Loader Clearance Circle, Bucket Carry Position	14.15 m (46 ft. 5 in.)	14.31 m (46 ft. 11 in.)	14.16 m (46 ft. 5 in.)	14.16 m (46 ft. 5 in.)	14.32 m (47 ft. 0 in.)	14.16 m (46 ft. 6 in.)	14.21 m (46 ft. 8 in.)	14.37 m (47 ft. 2 in.)	14.22 m (46 ft. 8 in.)	14.24 m (46 ft. 9 in.)	14.40 m (47 ft. 3 in.)	14.24 m (46 ft. 9 in.)	14.40 m (47 ft. 3 in.)

824 P-TIER

While general information, pictures, and descriptions are provided, some illustrations and text may include product options and accessories NOT AVAILABLE in all regions, and in some countries products and accessories may require modifications or additions to ensure compliance with the local regulations of those countries.

Dimensions and Specifications With Coupler and Hook-On Bucket (continued)													
824 P-TIER													
	Standard-Lift	Standard-Lift	Standard-Lift	Standard-Lift	Standard-Lift	Standard-Lift	Standard-Lift	Standard-Lift	Standard-Lift	Standard-Lift	Standard-Lift	High-Lift	
Specifications With Bucket	3.8-m ³ (5.0 cu. yd.) enhanced performance			4.0-m ³ (5.25 cu. yd.) enhanced performance			4.4-m ³ (5.75 cu. yd.) enhanced performance			4.6-m ³ (6.0 cu. yd.) enhanced performance			4.4-m ³ (5.75 cu. yd.) enhanced performance
Cutting Edge Type	bolt-on edge	teeth and segments	JAGZ	bolt-on edge	teeth and segments	JAGZ	bolt-on edge	teeth and segments	JAGZ	bolt-on edge	teeth and segments	JAGZ	bolt-on edge
Capacity, Heaped	3.8 m ³ (5.0 cu. yd.)	3.8 m ³ (5.0 cu. yd.)	3.8 m ³ (5.0 cu. yd.)	4.0 m ³ (5.25 cu. yd.)	4.0 m ³ (5.25 cu. yd.)	4.0 m ³ (5.25 cu. yd.)	4.4 m ³ (5.75 cu. yd.)	4.4 m ³ (5.75 cu. yd.)	4.4 m ³ (5.75 cu. yd.)	4.6 m ³ (6.0 cu. yd.)	4.6 m ³ (6.0 cu. yd.)	4.6 m ³ (6.0 cu. yd.)	4.4 m ³ (5.75 cu. yd.)
Capacity, Heaped at 110% Fill Factor													
EPA FT4/EU Stage V	4.2 m ³ (5.5 cu. yd.)	4.2 m ³ (5.5 cu. yd.)	4.2 m ³ (5.5 cu. yd.)	4.4 m ³ (5.75 cu. yd.)	4.4 m ³ (5.75 cu. yd.)	4.4 m ³ (5.75 cu. yd.)	4.8 m ³ (6.33 cu. yd.)	4.8 m ³ (6.33 cu. yd.)	4.8 m ³ (6.33 cu. yd.)	4.6 m ³ (6.0 cu. yd.)	4.6 m ³ (6.0 cu. yd.)	4.6 m ³ (6.0 cu. yd.)	4.8 m ³ (6.33 cu. yd.)
EPA Tier 3/EU Stage IIIA	4.2 m ³ (5.5 cu. yd.)	4.2 m ³ (5.5 cu. yd.)	4.2 m ³ (5.5 cu. yd.)	4.4 m ³ (5.75 cu. yd.)	4.4 m ³ (5.75 cu. yd.)	4.4 m ³ (5.75 cu. yd.)	4.8 m ³ (6.33 cu. yd.)	4.8 m ³ (6.33 cu. yd.)	4.8 m ³ (6.33 cu. yd.)	5.1 m ³ (6.6 cu. yd.)	5.1 m ³ (6.6 cu. yd.)	5.1 m ³ (6.6 cu. yd.)	4.8 m ³ (6.33 cu. yd.)
Capacity, Struck	3.25 m ³ (4.25 cu. yd.)	3.25 m ³ (4.25 cu. yd.)	3.25 m ³ (4.25 cu. yd.)	3.4 m ³ (4.5 cu. yd.)	3.4 m ³ (4.5 cu. yd.)	3.4 m ³ (4.5 cu. yd.)	3.8 m ³ (4.97 cu. yd.)	3.8 m ³ (4.97 cu. yd.)	3.8 m ³ (4.97 cu. yd.)	4.0 m ³ (5.25 cu. yd.)	4.0 m ³ (5.25 cu. yd.)	4.0 m ³ (5.25 cu. yd.)	3.8 m ³ (4.97 cu. yd.)
Bucket Weight With Bolt-On Cutting Edge	2499 kg (5,509 lb.)	2625 kg (5,788 lb.)	2522 kg (5,560 lb.)	2586 kg (5,701 lb.)	2712 kg (5,980 lb.)	2609 kg (5,752 lb.)	2672 kg (5,890 lb.)	2735 kg (6,031 lb.)	2695 kg (5,941 lb.)	2730 kg (6,019 lb.)	2857 kg (6,298 lb.)	2753 kg (6,070 lb.)	2672 kg (5,890 lb.)
Bucket Width	3.28 m (10 ft. 9 in.)	3.31 m (10 ft. 10 in.)	3.28 m (10 ft. 9 in.)	3.28 m (10 ft. 9 in.)	3.31 m (10 ft. 10 in.)	3.31 m (10 ft. 9 in.)	3.28 m (10 ft. 9 in.)	3.28 m (10 ft. 10 in.)	3.31 m (10 ft. 9 in.)	3.28 m (10 ft. 9 in.)	3.31 m (10 ft. 10 in.)	3.28 m (10 ft. 9 in.)	3.28 m (10 ft. 9 in.)
Breakout Force	18 001 kg (39,685 lb.)	15 908 kg (35,071 lb.)	18 025 kg (39,738 lb.)	17 834 kg (39,317 lb.)	15 767 kg (34,760 lb.)	17 856 kg (39,366 lb.)	16 768 kg (36,967 lb.)	14 905 kg (32,860 lb.)	16 787 kg (37,009 lb.)	16 266 kg (35,860 lb.)	14 494 kg (31,954 lb.)	16 283 kg (35,898 lb.)	15 681 kg (34,571 lb.)
Tipping Load, Straight, No Tire Deflection													
EPA FT4/EU Stage V	20 051 kg (44,205 lb.)	19 885 kg (43,839 lb.)	20 023 kg (44,143 lb.)	20 064 kg (44,233 lb.)	19 897 kg (43,865 lb.)	20 037 kg (44,174 lb.)	19 828 kg (43,713 lb.)	19 658 kg (43,338 lb.)	19 800 kg (43,651 lb.)	19 582 kg (43,171 lb.)	19 412 kg (42,796 lb.)	19 553 kg (43,107 lb.)	16 726 kg (36,874 lb.)
EPA Tier 3/EU Stage IIIA	19 594 kg (43,197 lb.)	19 427 kg (42,829 lb.)	19 566 kg (43,136 lb.)	19 605 kg (43,222 lb.)	19 437 kg (42,851 lb.)	19 577 kg (43,160 lb.)	19 371 kg (42,706 lb.)	19 202 kg (42,333 lb.)	19 343 kg (42,644 lb.)	19 129 kg (42,172 lb.)	18 959 kg (41,797 lb.)	19 101 kg (42,110 lb.)	16 325 kg (35,990 lb.)
Tipping Load, Straight, With Tire Deflection													
EPA FT4/EU Stage V	18 669 kg (41,158 lb.)	18 504 kg (40,794 lb.)	18 642 kg (41,099 lb.)	18 672 kg (41,165 lb.)	18 507 kg (40,801 lb.)	18 645 kg (41,105 lb.)	18 441 kg (40,655 lb.)	18 273 kg (40,285 lb.)	18 411 kg (40,589 lb.)	18 204 kg (40,133 lb.)	18 036 kg (39,763 lb.)	18 174 kg (40,067 lb.)	16 968 kg (37,408 lb.)
EPA Tier 3/EU Stage IIIA	18 255 kg (40,245 lb.)	18 090 kg (39,882 lb.)	18 228 kg (40,186 lb.)	18 258 kg (40,252 lb.)	18 093 kg (39,888 lb.)	18 231 kg (40,192 lb.)	18 027 kg (39,743 lb.)	17 862 kg (39,379 lb.)	18 000 kg (39,683 lb.)	17 796 kg (39,233 lb.)	17 628 kg (38,863 lb.)	17 766 kg (39,167 lb.)	16 575 kg (36,542 lb.)
Tipping Load, 37-deg. Partial Turn													
EPA FT4/EU Stage V	17 537 kg (38,662 lb.)	17 370 kg (38,294 lb.)	17 509 kg (38,601 lb.)	17 539 kg (38,667 lb.)	17 372 kg (38,299 lb.)	17 511 kg (38,605 lb.)	17 319 kg (38,182 lb.)	17 149 kg (37,807 lb.)	17 290 kg (38,118 lb.)	17 095 kg (37,688 lb.)	16 925 kg (37,313 lb.)	17 067 kg (37,626 lb.)	14 525 kg (32,022 lb.)
EPA Tier 3/EU Stage IIIA	17 129 kg (37,763 lb.)	16 962 kg (37,395 lb.)	17 101 kg (37,701 lb.)	17 129 kg (37,763 lb.)	16 962 kg (37,395 lb.)	17 102 kg (37,703 lb.)	16 911 kg (37,282 lb.)	16 742 kg (36,910 lb.)	16 883 kg (37,221 lb.)	16 691 kg (36,797 lb.)	16 522 kg (36,425 lb.)	16 663 kg (36,736 lb.)	14 168 kg (31,235 lb.)
Tipping Load, 40-deg. Full Turn, No Tire Deflection													
EPA FT4/EU Stage V	17 130 kg (37,765 lb.)	16 963 kg (37,397 lb.)	17 102 kg (37,703 lb.)	17 131 kg (37,767 lb.)	16 963 kg (37,397 lb.)	17 103 kg (37,706 lb.)	16 912 kg (37,285 lb.)	16 743 kg (36,912 lb.)	16 884 kg (37,223 lb.)	16 692 kg (36,800 lb.)	16 523 kg (36,427 lb.)	16 664 kg (36,738 lb.)	14 169 kg (31,237 lb.)
EPA Tier 3/EU Stage IIIA	16 730 kg (36,883 lb.)	16 563 kg (36,515 lb.)	16 702 kg (36,822 lb.)	16 729 kg (36,881 lb.)	16 561 kg (36,511 lb.)	16 701 kg (36,819 lb.)	16 513 kg (36,405 lb.)	16 344 kg (36,032 lb.)	16 485 kg (36,343 lb.)	16 297 kg (35,929 lb.)	16 127 kg (35,554 lb.)	16 268 kg (35,865 lb.)	13 818 kg (30,463 lb.)
Tipping Load, 40-deg. Full Turn, With Tire Deflection													
EPA FT4/EU Stage V	15 318 kg (33,770 lb.)	15 153 kg (33,407 lb.)	15 291 kg (33,711 lb.)	15 306 kg (33,744 lb.)	15 144 kg (33,387 lb.)	15 279 kg (33,684 lb.)	15 093 kg (33,274 lb.)	14 925 kg (32,904 lb.)	15 066 kg (33,215 lb.)	14 883 kg (32,811 lb.)	14 718 kg (32,448 lb.)	14 856 kg (32,752 lb.)	13 992 kg (30,847 lb.)
EPA Tier 3/EU Stage IIIA	14 979 kg (33,023 lb.)	14 817 kg (32,666 lb.)	14 952 kg (32,963 lb.)	14 967 kg (32,997 lb.)	14 802 kg (32,633 lb.)	14 940 kg (32,937 lb.)	14 757 kg (32,534 lb.)	14 589 kg (32,163 lb.)	14 727 kg (32,467 lb.)	14 550 kg (32,077 lb.)	14 385 kg (31,713 lb.)	14 523 kg (32,018 lb.)	13 662 kg (30,120 lb.)
Rated Operating Load, 50% Full-Turn Tipping Load, With Tire Deflection (conforms to ISO 14397-1)*													
EPA FT4/EU Stage V	7659 kg (16,885 lb.)	7577 kg (16,704 lb.)	7646 kg (16,857 lb.)	7653 kg (16,872 lb.)	7572 kg (16,693 lb.)	7640 kg (16,843 lb.)	7547 kg (16,638 lb.)	7463 kg (16,453 lb.)	7533 kg (16,607 lb.)	7442 kg (16,407 lb.)	7359 kg (16,224 lb.)	7428 kg (16,376 lb.)	6996 kg (15,424 lb.)
EPA Tier 3/EU Stage IIIA	7490 kg (16,513 lb.)	7409 kg (16,334 lb.)	7476 kg (16,482 lb.)	7484 kg (16,499 lb.)	7401 kg (16,316 lb.)	7470 kg (16,469 lb.)	7379 kg (16,268 lb.)	7295 kg (16,083 lb.)	7364 kg (16,235 lb.)	7275 kg (16,039 lb.)	7193 kg (15,858 lb.)	7262 kg (16,010 lb.)	6831 kg (15,060 lb.)
Operating Weight													
EPA FT4/EU Stage V	27 549 kg (60,735 lb.)	27 675 kg (61,013 lb.)	27 572 kg (60,786 lb.)	27 633 kg (60,920 lb.)	27 760 kg (61,200 lb.)	27 656 kg (60,971 lb.)	27 722 kg (61,116 lb.)	27 848 kg (61,394 lb.)	27 745 kg (61,167 lb.)	27 778 kg (61,240 lb.)	27 904 kg (61,518 lb.)	27 801 kg (61,291 lb.)	28 101 kg (61,952 lb.)
EPA Tier 3/EU Stage IIIA	27 251 kg (60,078 lb.)	27 378 kg (60,358 lb.)	27 274 kg (60,129 lb.)	27 336 kg (60,265 lb.)	27 462 kg (60,543 lb.)	27 359 kg (60,316 lb.)	27 424 kg (60,459 lb.)	27 551 kg (60,739 lb.)	27 447 kg (60,510 lb.)	27 480 kg (60,583 lb.)	27 607 kg (60,863 lb.)	27 503 kg (60,634 lb.)	27 804 kg (61,297 lb.)
Loader operating information is based on machine with identified linkage and standard equipment, JD9 PSS 6090 (EPA Final Tier 4/EU Stage V) engine, ROPS cab, rear cast bumper/counterweight, transmission side-frame guards, bottom guards, standard tires, full fuel tank, and 79-kg (175 lb.) operator. This information is affected by changes in tires, ballast, and different attachments.													
*Rated operating capacity based on Deere attachments only.													

While general information, pictures, and descriptions are provided, some illustrations and text may include product options and accessories NOT AVAILABLE in all regions, and in some countries products and accessories may require modifications or additions to ensure compliance with the local regulations of those countries.

824 P-TIER

Dimensions and Specifications With Coupler and Hook-On Construction Forks

824 P-TIER

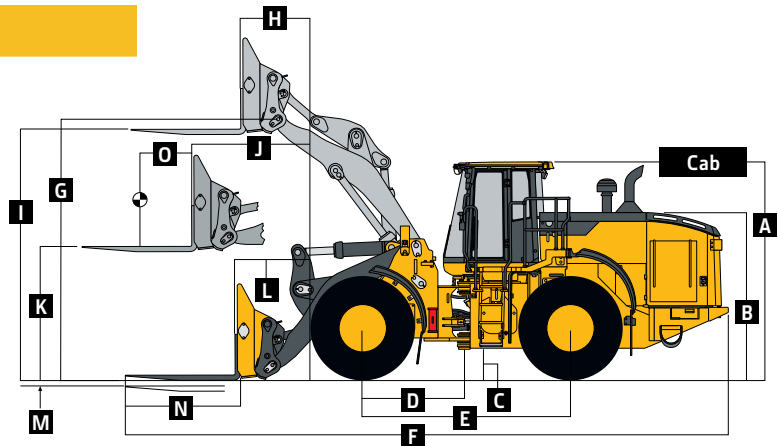

824 P-TIER STANDARD-LIFT AND HIGH-LIFT LOADERS WITH HOOK-ON CONSTRUCTION FORKS

	Standard-Lift	Standard-Lift	High-Lift
	1.83-m (72 in.) tine length	2.44-m (96 in.) tine length	1.83-m (72 in.) tine length
Dimensions With Forks			
A Height to Top of Cab	3.57 m (11 ft. 9 in.)	3.57 m (11 ft. 9 in.)	3.57 m (11 ft. 9 in.)
B Hood Height	2.73 m (8 ft. 11 in.)	2.73 m (8 ft. 11 in.)	2.73 m (8 ft. 11 in.)
C Ground Clearance	458 mm (18 in.)	458 mm (18 in.)	458 mm (18 in.)
D Length From Centerline to Front Axle	1.70 m (5 ft. 7 in.)	1.70 m (5 ft. 7 in.)	1.70 m (5 ft. 7 in.)
E Wheelbase	3.46 m (11 ft. 4 in.)	3.46 m (11 ft. 4 in.)	3.46 m (11 ft. 4 in.)
F Overall Length, Forks on Ground	9.96 m (32 ft. 8 in.)	10.57 m (34 ft. 8 in.)	10.49 m (34 ft. 5 in.)
G Height to Hinge Pin, Fully Raised	4.48 m (14 ft. 9 in.)	4.48 m (14 ft. 9 in.)	4.48 m (14 ft. 9 in.)
H Reach, Fully Raised	0.81 m (32 in.)	0.81 m (32 in.)	1.05 m (3 ft. 5 in.)
I Fork Height, Fully Raised	3.45 m (11 ft. 4 in.)	3.45 m (11 ft. 4 in.)	3.79 m (12 ft. 5 in.)
J Maximum Reach, Fork Level	1.87 m (6 ft. 2 in.)	1.87 m (6 ft. 2 in.)	2.29 m (7 ft. 6 in.)
K Fork Height, Maximum Reach	1.29 m (4 ft. 3 in.)	1.29 m (4 ft. 3 in.)	1.29 m (4 ft. 3 in.)
L Reach, Ground Level	1.14 m (3 ft. 9 in.)	1.14 m (3 ft. 9 in.)	1.67 m (5 ft. 6 in.)
M Depth Below Ground	55 mm (2.2 in.)	55 mm (2.2 in.)	59 mm (2.3 in.)
N Tine Length	1.83 m (72 in.)	2.44 m (96 in.)	1.83 m (72 in.)
O Load Position, 50% Tine Length	0.92 m (36 in.)	1.22 m (48 in.)	0.92 m (36 in.)
Specifications With Forks			
Tipping Load, Straight, No Tire Deflection			
EPA FT4/EU Stage V	14 275 kg (31,471 lb.)	12 992 kg (28,642 lb.)	12 442 kg (27,430 lb.)
EPA Tier 3/EU Stage IIIA	13 962 kg (30,781 lb.)	12 703 kg (28,005 lb.)	12 160 kg (26,808 lb.)
Tipping Load, Straight, With Tire Deflection			
EPA FT4/EU Stage V	13 827 kg (30,483 lb.)	12 603 kg (27,785 lb.)	12 069 kg (26,608 lb.)
EPA Tier 3/EU Stage IIIA	13 527 kg (29,822 lb.)	12 324 kg (27,170 lb.)	11 799 kg (26,012 lb.)
Tipping Load, 37-deg. Partial Turn, No Tire Deflection			
EPA FT4/EU Stage V	12 554 kg (27,677 lb.)	11 402 kg (25,137 lb.)	10 895 kg (24,019 lb.)
EPA Tier 3/EU Stage IIIA	12 275 kg (27,062 lb.)	11 144 kg (24,568 lb.)	10 644 kg (23,466 lb.)
Tipping Load, 40-deg. Full Turn, No Tire Deflection			
EPA FT4/EU Stage V	12 276 kg (27,064 lb.)	11 145 kg (24,570 lb.)	10 645 kg (23,468 lb.)
EPA Tier 3/EU Stage IIIA	12 002 kg (26,460 lb.)	10 892 kg (24,013 lb.)	10 399 kg (22,926 lb.)
Tipping Load, 40-deg. Full Turn, With Tire Deflection			
EPA FT4/EU Stage V	11 649 kg (25,682 lb.)	10 596 kg (23,360 lb.)	10 119 kg (22,309 lb.)
EPA Tier 3/EU Stage IIIA	11 394 kg (25,119 lb.)	10 362 kg (22,844 lb.)	9888 kg (21,799 lb.)
Rated Operating Load, 50% Full-Turn Tipping Load, With Tire Deflection (conforms to ISO 14397-1)*			
EPA FT4/EU Stage V	5825 kg (12,842 lb.)	5298 kg (11,680 lb.)	5060 kg (11,155 lb.)
EPA Tier 3/EU Stage IIIA	5697 kg (12,560 lb.)	5181 kg (11,422 lb.)	4944 kg (10,900 lb.)
Rated Operating Load, Rough Terrain, 60% Full-Turn Tipping Load, With Tire Deflection (conforms to EN474-3)*			
EPA FT4/EU Stage V	6989 kg (15,408 lb.)	6358 kg (14,017 lb.)	6071 kg (13,384 lb.)
EPA Tier 3/EU Stage IIIA	6836 kg (15,071 lb.)	6217 kg (13,706 lb.)	5933 kg (13,080 lb.)
Rated Operating Load, Firm and Level Ground, 80% Full-Turn Tipping Load, With Tire Deflection (conforms to EN474-3)*			
EPA FT4/EU Stage V	9319 kg (20,545 lb.)	8477 kg (18,689 lb.)	8095 kg (17,846 lb.)
EPA Tier 3/EU Stage IIIA	9115 kg (20,095 lb.)	8290 kg (18,276 lb.)	7910 kg (17,439 lb.)
Operating Weight			
EPA FT4/EU Stage V	26 481 kg (58,381 lb.)	26 654 kg (58,762 lb.)	26 860 kg (59,216 lb.)
EPA Tier 3/EU Stage IIIA	26 184 kg (57,726 lb.)	26 356 kg (58,105 lb.)	26 563 kg (58,561 lb.)

Loader operating information is based on machine with identified linkage and standard equipment, JD9 PSS 6090 (EPA Final Tier 4/EU Stage V) engine, ROPS cab, rear cast bumper/counterweight, transmission side-frame guards, bottom guards, standard tires, full fuel tank, and 79-kg (175 lb.) operator. This information is affected by changes in tires, ballast, and different attachments.

*Rated operating capacity based on Deere attachments only.

824 P-TIER

While general information, pictures, and descriptions are provided, some illustrations and text may include product options and accessories NOT AVAILABLE in all regions, and in some countries products and accessories may require modifications or additions to ensure compliance with the local regulations of those countries.

Adjustments to Operating Weights and Tipping Loads With Buckets 824 P-TIER

Adjustments to operating weights, tipping loads, and tires are based on Standard-Lift machine with pin-on 4.6-m³ (6.0 cu. yd.) enhanced-performance bucket with bolt-on cutting edge, ROPS cab, rear cast bumper/counterweight, transmission side-frame guards, bottom guards, standard tires, full fuel tank, and 79-kg (175 lb.) operator*

Add (+) or deduct (-) kg (lb.) as indicated for loaders with 3-piece rims	Operating Weight	Tipping Load,			Tread Width	Width Over Tires	Vertical Height
		Straight	37-deg. Partial Turn	40-deg. Full Turn			
Michelin 26.5 R 25, 2 Star L-3	0 kg (0 lb.)	0 kg (0 lb.)	0 kg (0 lb.)	0 kg (0 lb.)	0 mm (0 in.)	0 mm (0 in.)	0 mm (0 in.)
Titan 26.5 R 25, 1 Star L-3	0 kg (0 lb.)	0 kg (0 lb.)	0 kg (0 lb.)	0 kg (0 lb.)	0 mm (0 in.)	-7 mm (-0.27 in.)	+4 mm (+0.16 in.)
Goodyear 26.5 R 25, 1 Star L-3	-56 kg (-123 lb.)	-39 kg (-86 lb.)	-35 kg (-77 lb.)	-35 kg (-77 lb.)	0 mm (0 in.)	+1 mm (+0.04 in.)	+4 mm (+0.16 in.)
Firestone 26.5-25, 20-Ply L-3	-360 kg (-794 lb.)	-254 kg (-560 lb.)	-228 kg (-503 lb.)	-224 kg (-494 lb.)	0 mm (0 in.)	-28 mm (-1.10 in.)	+39 mm (+1.53 in.)
Firestone 26.5-25, 20-Ply L-5 [§]	+312 kg (+688 lb.)	+220 kg (+485 lb.)	+197 kg (+434 lb.)	+194 kg (+428 lb.)	0 mm (0 in.)	-18 mm (-0.70 in.)	+63 mm (+2.48 in.)
Michelin 29.5 R 25, 2 Star L-3 [§]	+604 kg (+1,332 lb.)	+426 kg (+939 lb.)	+382 kg (+842 lb.)	+375 kg (+827 lb.)	0 mm (0 in.)	+82 mm (+3.23 in.)	+69 mm (+2.71 in.)
Titan 29.5 R 25, 1 Star L-3 [§]	+664 kg (+1,464 lb.)	+468 kg (+1,032 lb.)	+420 kg (+926 lb.)	+412 kg (+908 lb.)	0 mm (0 in.)	+58 mm (+2.30 in.)	+80 mm (+3.10 in.)
Bridgestone 29.5 R 25, 1 Star L-3 [§]	+720 kg (+1,587 lb.)	+508 kg (+1,120 lb.)	+456 kg (+1,005 lb.)	+447 kg (+985 lb.)	0 mm (0 in.)	+71 mm (+2.80 in.)	+78 mm (+3.00 in.)
Michelin 775/65 R29, 1 Star L-3 [§]	+726 kg (+1,601 lb.)	+512 kg (+1,129 lb.)	+459 kg (+1,012 lb.)	+451 kg (+994 lb.)	0 mm (0 in.)	+104 mm (+4.09 in.)	+23 mm (+0.91 in.)
Bridgestone 775/65 R29, 1 Star L-3 [§]	+876 kg (+1,931 lb.)	+618 kg (+1,362 lb.)	+554 kg (+1,221 lb.)	+554 kg (+1,199 lb.)	0 mm (0 in.)	+99 mm (+3.90 in.)	+14 mm (+0.55 in.)
4.8-m ³ (6.25 cu. yd.) Enhanced-Performance Bucket With Wear Liners							
EPA FT4/EU Stage V	+264 kg (+582 lb.)	-526 kg (-1,160 lb.)	-500 kg (-1,102 lb.)	-496 kg (-1,093 lb.)	0 mm (0 in.)	0 mm (0 in.)	0 mm (0 in.)
EPA Tier 3/EU Stage IIIA	+264 kg (+582 lb.)	-521 kg (-1,149 lb.)	-496 kg (-1,093 lb.)	-492 kg (-1,085 lb.)	0 mm (0 in.)	0 mm (0 in.)	0 mm (0 in.)
5.2-m ³ (6.75 cu. yd.) Material-Handling Bucket With Wear Liners							
EPA FT4/EU Stage V	+305 kg (+672 lb.)	-685 kg (-1,510 lb.)	-646 kg (-1,424 lb.)	-640 kg (-1,411 lb.)	0 mm (0 in.)	0 mm (0 in.)	0 mm (0 in.)
EPA Tier 3/EU Stage IIIA	+305 kg (+672 lb.)	-678 kg (-1,495 lb.)	-640 kg (-1,411 lb.)	-634 kg (-1,398 lb.)	0 mm (0 in.)	0 mm (0 in.)	0 mm (0 in.)
High-Lift Boom							
EPA FT4/EU Stage V	+379 kg (+836 lb.)	-3247 kg (-7,158 lb.)	-2922 kg (-6,442 lb.)	-2869 kg (-6,325 lb.)	0 mm (0 in.)	0 mm (0 in.)	0 mm (0 in.)
EPA Tier 3/EU Stage IIIA	+379 kg (+836 lb.)	-3186 kg (-7,024 lb.)	-2868 kg (-6,323 lb.)	-2816 kg (-6,208 lb.)	0 mm (0 in.)	0 mm (0 in.)	0 mm (0 in.)

*May change based on vehicle configuration, weight, or tire-pressure adjustments.

[§]Requires 8-deg. rear axle stops.

While general information, pictures, and descriptions are provided, some illustrations and text may include product options and accessories NOT AVAILABLE in all regions, and in some countries products and accessories may require modifications or additions to ensure compliance with the local regulations of those countries.

824 P-TIER

Bucket Selection Guides

824 P-TIER

LOOSE MATERIALS	kg/m ³	lb./cu. yd.	LOOSE MATERIALS	kg/m ³	lb./cu. yd.
Chips, pulpwood	288	486	Limestone, coarse, sized	1570	2,646
Cinders (coal, ashes, clinkers)	673	1,134	Limestone, mixed sizes	1682	2,835
Clay and gravel, dry	1602	2,700	Limestone, pulverized or crushed	1962	2,295
Clay, compact, solid	1746	2,943	Sand, damp	2083	3,510
Clay, dry in lump loose	1009	1,701	Sand, dry	1762	2,970
Clay, excavated in water	1282	2,160	Sand, voids, full of water	2083	3,510
Coal, anthracite, broken, loose	865	1,458	Sandstone, quarried	1314	2,214
Coal, bituminous, moderately wet	801	1,350	Shale, broken crushed	1362	2,295
Earth, common loam, dry	1218	2,052	Slag, furnace granulated	1955	3,294
Earth, mud, packed	1843	3,105	Stone or gravel, 37.5 to 87.5-mm (1.5 to 3.5 in.) size	1442	2,430
Granite, broken	1538	2,592	Stone or gravel, 18.75-mm (0.75 in.) size	1602	2,700
Gypsum	2275	3,834			

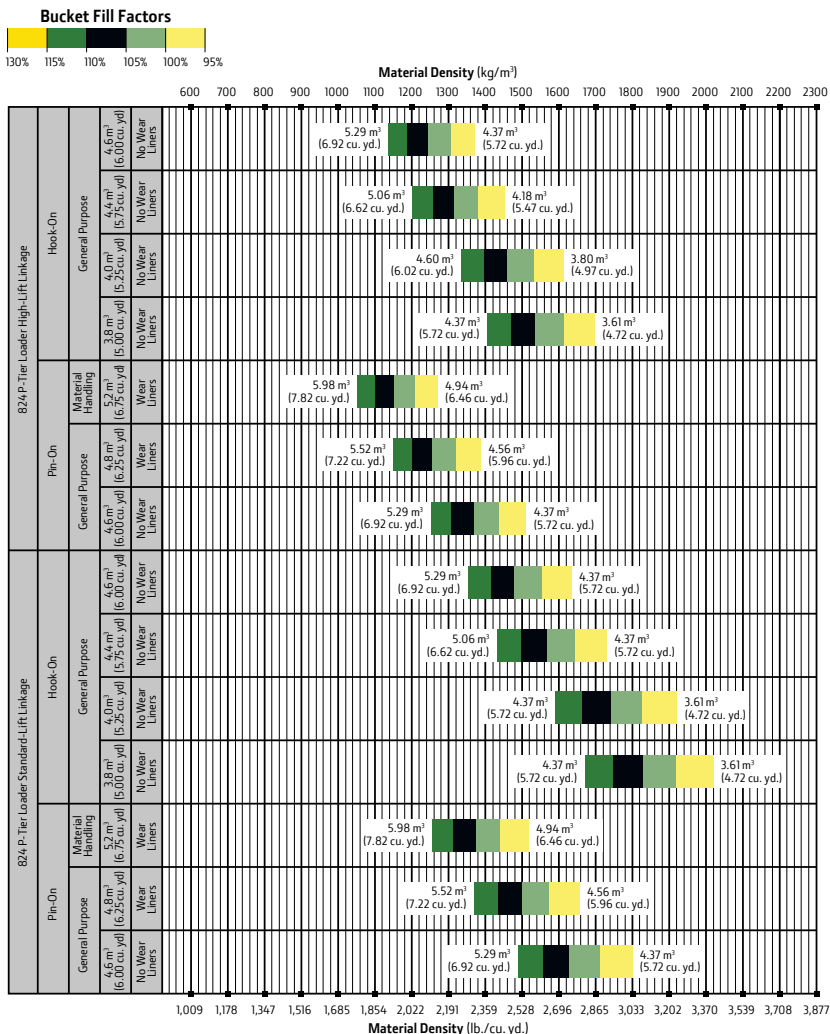

Additional equipment

Key: ● Standard ▲ Optional or special

See your John Deere dealer for further information.

824 P Engine

- Wet-sleeve cylinder liners
- Programmable auto-idle and auto shutdown
- Selected idle adjustment from 900–1,250 rpm
- Starter excessive-cranking protection
- Automatic engine cool-down timer
- Automatic derating for exceeded system temperatures
- Serpentine drive belt for automatic tensioner
- Electrical fuel-priming pump
- Dual-stage fuel filter and water separator
- 500-hour vertical spin-on oil filter
- Engine-compartment light
- ▲ Chrome exhaust stack
- ▲ Automatic ether starting aid and engine block heater (recommended for cold starts below –12 deg. C [10 deg. F])
- Centrifugal engine air pre-cleaner
- ▲ Throttle lock

Powertrain

- Clutch cutoff with 4 operator settings: Automatic, level ground, small slope, or steep slope
- Programmable maximum high gear
- Clutch calibration engaged from monitor
- 2,000-hour vertical spin-on transmission filter
- Transmission fill tube with sight gauge
- Transmission diagnostic ports
- 5-speed transmission with lockup torque converter
- Front locking differential
- ▲ Rear locking differential
- Brake adjusters and retractors
- ▲ Automatic differential lock
- Axle oil temperature sensing
- Wheel-spin control

Quad-Cool™ Cooling System

- Heavy-duty, trash-resistant radiator and high-ambient cooling package
- 2-side access to all coolers

824 P Quad-Cool Cooling System (continued)

- Isolated from engine compartment
- Engine radiator
- Integral engine oil cooler
- Hydraulic oil cooler (oil to air)
- Transmission oil cooler (oil to air)
- Charge air cooler (air to air)
- Fuel cooler
- Coolant recovery tank with under-hood lighting
- Coolant-loss sensor
- Antifreeze, –37 deg. C (–34 deg. F)
- Cool-on-demand swing-out fan
- Enclosed fan safety guard
- Automatic reversing fan drive
- Axle and service-brake coolers

Hydraulics

- Electrohydraulic control with soft stops and adjustable settings
- In-cab adjustable automatic return-to-dig bucket positioner
- In-cab adjustable automatic boom-height kickout/return to carry
- Reservoir with sight gauge and fill strainer
- Hydraulic diagnostic ports
- 4,000-hour in-tank filter
- 2 function – 2-lever fingertip controls
- ▲ 2 function – joystick
- ▲ 2 function – joystick with F-N-R (steering wheel only)
- ▲ 3 function – 3-lever fingertip controls
- ▲ 3 function – joystick with integrated 3rd-function roller
- ▲ 3 function – joystick with integrated 3rd-function roller and F-N-R (steering wheel only)
- ▲ 4 function – joystick with integrated 3rd/4th-function rollers
- ▲ 4 function – joystick with integrated 3rd/4th-function rollers and F-N-R (steering wheel only)
- 2 programmable multifunction buttons
- Adjustable and continuous auxiliary hydraulic-flow settings
- Programmable attachment settings

824 P Hydraulics (continued)

- Ride control, automatic with monitor-adjustable speed settings
- ▲ Hydraulic control system for quick-coupler locking pins
- ▲ Hydrau™ XR cold-temperature hydraulic fluid recommended below –25 deg. C (–13 deg. F)

Steering Systems

- Joystick steering with gearshift, F-N-R, and horn
- ▲ Conventional steering wheel with spinner knob
- ▲ Secondary steering

Electrical

- Solid-state electrical power-distribution system
- Lockable master electrical-disconnect switch
- Battery-terminal safety covers
- By-pass start safety cover at starter
- Remote jump-start access in battery box
- Pre-wired for beacon/strobe light
- ▲ Beacon bracket (single or dual available)
- ▲ LED strobe beacon
- Lights: Halogen driving lights with guards (2) / Front (4), rear cab (2), and rear grille (2) work lights / LEF front turn signals and flashers / LED stop- and taillights
- ▲ Premium LED work, drive, and marker lights
- Programmable courtesy lights
- Horn, electric
- Reverse warning alarm
- Multifunction/multi-language 178-mm (7 in.) LCD color monitor includes: Digital instruments – Analog display (hydraulic oil temperature, engine coolant temperature, transmission oil temperature, and engine oil pressure) / Digital display (engine rpm, transmission gear/direction indicator, hour meter, fuel level, diesel exhaust fluid [DEF] level (EPA Final Tier 4/EU Stage V only), speedometer, odometer, and average fuel consumption)

While general information, pictures, and descriptions are provided, some illustrations and text may include product options and accessories NOT AVAILABLE in all regions, and in some countries products and accessories may require modifications or additions to ensure compliance with the local regulations of those countries.

Net engine power is with standard equipment including air cleaner, exhaust system, alternator, and cooling fan at test conditions per ISO 9249. No derating is required up to 3050-m (10,000 ft.) altitude. Specifications and design subject to change without notice. Specifications with the exception of bucket capacity are in accordance with all applicable ISO standards. Except where otherwise noted, these specifications are based on a unit with applicable linkage and standard equipment, ROPS cab, rear cast bumper/counterweight, transmission side-frame guards, bottom guards, standard tires, full fuel tank, and 79-kg (175 lb.) operator.

Additional equipment *(continued)*

Key: ● Standard ▲ Optional or special

See your John Deere dealer for further information.

824 P Electrical *(continued)*

- Integrated cycle counter with 5 categories
- Indicator lights: Standard and selected options / Amber caution and red stop
- Operator-warning messages
- Built-in diagnostics: Diagnostic-code details / Sensor values / Calibrations / Individual circuit tester
- ▲ Electrical corrosion-prevention package
- ▲ Premium AM/FM/Weather Band (WB) radio with Bluetooth®, remote auxiliary port, and remote USB port
- ▲ 24- to 12-volt, 30-amp converter with 3 in-cab power ports

Operator's Station

- Quiet Cab with air conditioning/heater (ROPS/FOPS Level 2, isolation mounted)
- Automatic temperature control
- Rear window defrost vent
- Keyless start with multiple security modes
- Sealed-switch module with function indicators
- Premium seat with high-wide back and headrest extension, heated and ventilated, leather/fabric cover, pan tilt/extend, damper adjustments, and adjustable heavy-duty air suspension
- Hydraulic controls and joystick steering integrated to seat
- High-visibility, bright-orange seat belt, 76 mm (3 in.), with retractors
- Seat-belt minder monitoring with JDLink™
- ▲ Seat-belt indicator beacon light
- Cup holder and cup/thermos holder with retaining strap
- Lunch-box/cooler holder with tie-down brackets
- LED dome and reading light
- Coat hook
- Rubber floor mat
- ▲ Dual-tilt steering column (steering wheel only)
- Operator's manual storage compartment
- Outside (2) and inside (2) rearview mirrors

824 P Operator's Station *(continued)*

- ▲ In-cab adjustable heated outside mirrors with convex lens
- Left-side operator-station access
- Front window-washing platforms with fall-arrest system anchor points tested to 2268 kg (5,000 lb.)
- Slip-resistant steps and ergonomic handholds
- Pull-down front sun visor
- ▲ Pull-down rear sun visor
- CB radio ready with 12-volt power, bracket, and antennae included
- Front and rear intermittent windshield wiper and washers
- ▲ Powered cab air pre-cleaner
- Rearview camera
- ▲ Advanced rear object-detection system (EPA FT4/EU Stage V only)
- ▲ Advanced vision system
- ▲ Rear object-detection system (EPA Tier 3/EU Stage IIIA only)
- Payload scale ready
- ▲ SmartWeigh™ ready + trial
- ▲ SmartWeigh
- ▲ Fire extinguisher

Loader Linkage

- Z-Bar loader linkage
- ▲ High-Lift Z-Bar loader linkage

Buckets and Attachments

- ▲ Full line of Deere pin-on buckets, hook-on buckets, and forks
- ▲ John Deere hydraulic coupler that accepts JRB 420-pattern attachments
- ▲ Bolt-on bucket spill guard
- ▲ Bushed pin joints (including static joints) on optional Enhanced-Performance buckets

Overall Vehicle

- JDLink wireless communication system (available in specific countries; see your dealer for details)
- ▲ Auto-lube system with empty reservoir sensor and diagnostics integrated into machine diagnostics and JDLink alerts

824 P Overall Vehicle *(continued)*

- Front and rear tie-downs
- Rear cast bumper with rear hitch and locking pin
- Articulation locking bar
- Loader boom service locking bar
- 40-deg. steering articulation to each side with rubber-cushion stops on frame
- Vandal protection with lockable engine enclosures, right counterweight storage, battery box, and filler access for radiator/fuel/hydraulic transmission
- Right and left handrails, platforms, and steps
- Service steps and handholds
- Storage compartment
- Fuel-tank fill strainer
- Heavy-duty fuel-tank guard
- Ground-level fueling and DEF
- Same-side ground-level daily servicing
- Environmental drains for engine, transmission, hydraulic oils, and engine coolant
- Fluid-sampling ports for engine, transmission, hydraulic and axle oils, and engine coolant
- 26.5R25 tires on 5-piece rims
- ▲ 775/65R29 tires on 5-piece rims
- ▲ Tire-pressure monitoring system
- Level 1 sound package
- Level 2 sound package
- Transmission side-frame and bottom guards
- ▲ Fast-fuel system
- ▲ Quick fluid service (engine, transmission, hydraulic oils, and engine coolant)
- Fenders, full-coverage, front
- ▲ Fenders, full-coverage, front and rear
- ▲ Fenders, roading, full-coverage, front and rear
- Lift eyes
- ▲ Wheel-chock-mounting brackets
- ▲ License-plate bracket and light
- ▲ Special guarding for waste and forestry applications

While general information, pictures, and descriptions are provided, some illustrations and text may include product options and accessories NOT AVAILABLE in all regions, and in some countries products and accessories may require modifications or additions to ensure compliance with the local regulations of those countries.

Net engine power is with standard equipment including air cleaner, exhaust system, alternator, and cooling fan at test conditions per ISO 9249. No derating is required up to 3050-m (10,000 ft.) altitude. Specifications and design subject to change without notice. Specifications with the exception of bucket capacity are in accordance with all applicable ISO standards. Except where otherwise noted, these specifications are based on a unit with applicable linkage and standard equipment, ROPS cab, rear cast bumper/counterweight, transmission side-frame guards, bottom guards, standard tires, full fuel tank, and 79-kg (175 lb.) operator.



MW824PAU (23-03)



JOHN DEERE