

724 P

Wheel Loader



JOHN DEERE



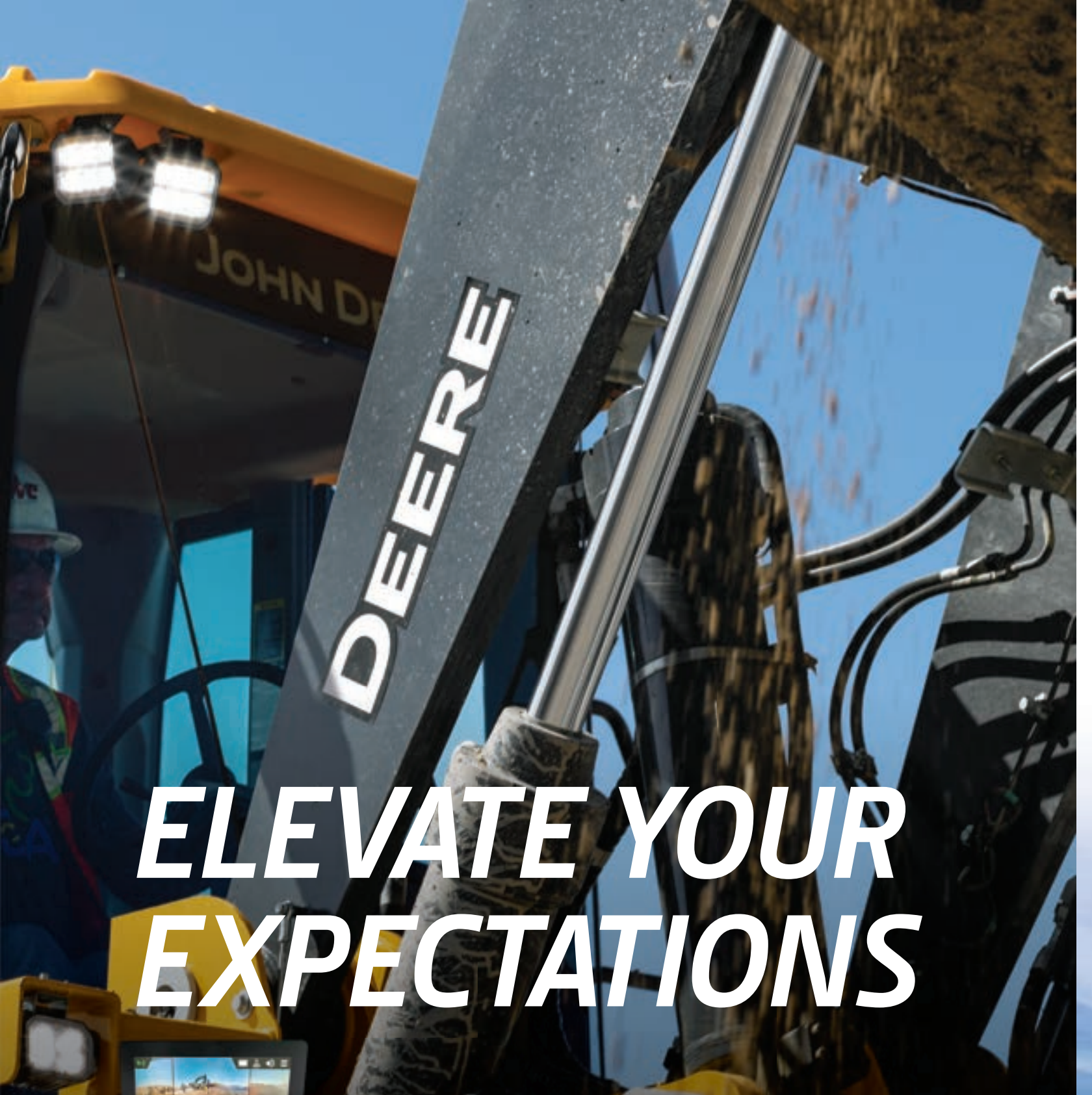

ELEVATE YOUR EXPECTATIONS



SEE IT LIKE NEVER BEFORE

New Advanced Vision System includes two digital cameras mounted on the rearview-mirror platforms that integrate with the rearview camera for a single display on a dedicated in-cab monitor. Overlaid within the monitor's rear-camera view, dynamic reversal projected-path lines help operators visualize the loader's anticipated reversal path based on its articulation, for sight lines to people or objects directly within the path.

ABOVE AND BEYOND

MEET THE P-TIER WHEEL LOADERS



**SMARTWEIGH™
PAYLOAD-WEIGHING
SOLUTION IS DEERE
DESIGNED & SUPPORTED**

When your material-handling application needs a heavy-duty lift, add a P-Tier Wheel Loader to your lineup. Combining convenient front-end features with near-parallel lift, spacious operator stations including customizable ergonomic electrohydraulic (EH) controls, streamlined electrical and hydraulic routing, and innovative options, these versatile and productive mid-size models are designed to help you take your operation to the next level.

At the forefront

Featuring bucket and linkage designs that improve load leveling, material retention, and visibility, P-Tier Loaders yield more productivity and performance than previous models. Enhanced-performance buckets with integrated spill guards, curved side cutters, and impressive rollback deliver elevated bucket-fill performance and material retention compared to earlier offerings.

On your side

All daily service points including fuel refill are conveniently grouped at ground level on the left side of the machine for easy access. Routing of electrical wire harnesses and hydraulic hoses has been streamlined.

Precision Construction

From grade management and obstacle detection to product automation features and jobsite intelligence, this suite of construction technology delivers productivity solutions to help you get more done, more efficiently.

John Deere construction equipment comes with in-base connectivity — free from subscriptions or annual renewals. Analyze critical machine data, track utilization, review diagnostic alerts, and more from **the John Deere Operations Center™**. The Operations Center also enables **John Deere Connected Support™**, which uses data from thousands of connected machines to proactively address issues before they arise. Your dealer can also remotely monitor machine health, diagnose problems, and even update machine software without a trip to the jobsite.*

*Availability varies by region and product.
Options not available in every country.

Material matters

SmartWeigh option features dynamic weighing technology that allows operators to weigh without interrupting workflow and removes the need to lower and reraise the boom after tipoff. Shared through the onboard monitor, SmartWeigh is easy to calibrate and effortlessly integrates with JDLink so you can track and visualize payload data from almost anywhere. Available as a factory-installed or field-kit option, you can also try SmartWeigh at a low cost for 250 machine hours.

Level up

AutoLevel enables near-perfect parallelism throughout the boom-raise-and-lower cycle, letting operators set their desired attachment angle to within \pm two degrees.



724 P

WHEEL LOADER



**2 INDUSTRY-EXCLUSIVE
MULTIFUNCTION BUTTONS**



GET AHEAD

MOVING FORWARD.

Designed to elevate your productivity, the 724 P-Tier Wheel Loader helps you put your best foot forward.



Have a seat

Spacious and comfortable cab features extra legroom, an improved HVAC system, additional storage, and a more adjustable seat than earlier models.



Take control

Operators can easily control up to six functions without letting go of the ergonomically designed joystick. Two industry-exclusive multifunction buttons can each be programmed to handle any of up to 10 functions selected through the monitor, including bucket vibrate and electrohydraulic (EH) Precision mode.

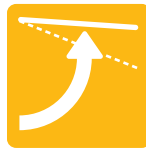

Near-parallel lift

Lift path on Z-Bar linkage is near parallel. Better load-leveling capability compared to K-Series models minimizes load rollback, reduces material spillage, and requires fewer manual adjustments. Cross-tube and boom geometry of the Z-Bar linkage has been streamlined to provide a better view to the front attachment.



Reach your potential

Three additional inches of hinge-pin height over the 724K provides more clearance for dumping into high feeders, hoppers, trucks, and wagons.



Clear advantage

Improved visibility to the work tool helps reduce spillage as well as cycle and tool-changeover times. It also helps minimize machine damage when working on crowded jobsites or up against walls.



Step it up

Quad-Cool™ places the radiator, air-conditioner condenser, intercooler, and hydraulic, transmission, and axle coolers in a unique boxed configuration that's isolated from engine heat, boosting efficiency and durability.



While general information, pictures, and descriptions are provided, some illustrations and text may include product options and accessories NOT AVAILABLE in all regions, and in some countries products and accessories may require modifications or additions to ensure compliance with the local regulations of those countries.

Engine		724 P-TIER Z-BAR / HIGH-LIFT	
Manufacturer and Model	John Deere PowerTech™ PSS 6090	Gross Peak Torque (ISO 9249)	1325 Nm (977 lb.-ft.) at 1,300 rpm
Non-Road Emission Standard	EPA Final Tier 4/EU Stage V	Net Torque Rise	48%
Cylinders	6	Fuel System (electronically controlled)	High-pressure common rail
Valves Per Cylinder	4	Lubrication	Full-flow spin-on filter and integral cooler
Displacement	9.0 L (548 cu. in.)	Aspiration	Series turbocharged, charge air cooled
Net Peak Power (ISO 9249)	200 kW (268 hp) at 1,800 rpm	Air Cleaner	Under-hood, dual-element dry type, restriction indicator in cab monitor for service
Gross Peak Power (ISO 9249)	206 kW (276 hp) at 1,800 rpm		
Net Peak Torque (ISO 9249)	1290 Nm (951 lb.-ft.) at 1,400 rpm		
Cooling			
Fan Drive	Hydraulically driven, proportionally controlled, fan aft of coolers		
Electrical			
Electrical System	24 volt with 100-amp alternator (140-amp alternator optional)		
Batteries (2 – 12 volt)	950 CCA (each)		
Transmission System			
Type	Countershaft-type PowerShift™		
Torque Converter	Single stage, single phase		
Shift Control	Electronically modulated, adaptive, load and speed dependent		
Operator Interface	Steering-column or joystick-mounted F-N-R and gear-select lever; Quick-Shift button on hydraulic lever		
Shift Modes	Manual/auto (1st–D or 2nd–D); Quick-Shift button with 2 selectable modes: kick-down or kick-up/down; and 4 clutch cutoff settings		
	<i>Standard 5-Speed With Lockup Torque Converter</i>		<i>Optional 4-Speed</i>
Maximum Travel Speeds (with 23.5 R 25, 1 Star L3 tires)			
	<i>Forward</i>	<i>Reverse</i>	
Range 1	7.1 km/h (4.4 mph)	7.5 km/h (4.7 mph)	7.2 km/h (4.5 mph)
Range 2	12.1 km/h (7.5 mph)	12.8 km/h (8.0 mph)	11.9 km/h (7.4 mph)
Range 3	20.5 km/h (12.7 mph)	26.1 km/h (16.2 mph)	22.9 km/h (14.2 mph)
Range 4	24.7 km/h (15.3 mph)	N/A	35.2 km/h (21.9 mph)
Range 5	40.0 km/h (24.9 mph)	N/A	N/A
Axles/Brakes			
Final Drives	Heavy-duty inboard-mounted planetary		
Differentials	Hydraulic locking front with conventional rear – standard; dual locking front and rear – optional		
Rear Axle Oscillation, Stop to Stop (with 23.5 R 25 tires)	26 deg. (13 deg. each direction)		
Brakes (conform to ISO 3450)			
Service	Hydraulically actuated, spring retracted, self-adjusting, inboard sun-shaft mounted, oil cooled, single disc		
Parking	Automatic spring applied, hydraulically released, driveline mounted, oil cooled, multi disc		
Tires/Wheels (see page 9 for complete tire adjustments)			
	<i>Tread Width</i>	<i>Width Over Tires</i>	
Michelin 23.5 R 25, 1 Star L-3	2170 mm (85.4 in.)	2880 mm (113.4 in.)	
Serviceability			
Refill Capacities		Refill Capacities (continued)	
Fuel Tank (with lockable cap)	351 L (92.6 gal.)	Transmission Reservoir With Vertical Filter	23 L (24.3 qt.)
Diesel Exhaust Fluid (DEF)	18.5 L (19.5 qt.)	Axle Oil Without Coolers (front and rear, each)	22 L (23 qt.)
Cooling System	48 L (51 qt.)	Hydraulic Reservoir and Filter	105.2 L (27.8 gal.)
Engine Oil With Vertical Spin-On Filter	28 L (29.5 qt.)	Park Brake Oil (wet disc)	0.65 L (22 oz.)
Hydraulic System/Steering			
Pump (loader and steering)	Variable-displacement, axial-piston pump; closed-center, pressure-compensating system		
Maximum Rated Flow at 6895 kPa (1,000 psi) and 2,250 rpm	310 L/m (82 gpm)		
System Relief Pressure (loader and steering)	27 580 kPa (4,000 psi)		
Loader Controls	2-function valve; joystick control or fingertip controls; hydraulic-function enable/disable; optional 3rd-function valve with roller or auxiliary lever and 4th-function valve with dual roller		
Steering (conforms to ISO 5010)			
Type	Power, fully hydraulic		
Articulation Angle	80-deg. arc (40 deg. each direction)		
Turning Radius (measured to centerline of outside tire)	5.64 m (18 ft. 6 in.)		

724 P-TIER WHEEL LOADER SPECIFICATIONS

724

P

While general information, pictures, and descriptions are provided, some illustrations and text may include product options and accessories NOT AVAILABLE in all regions, and in some countries products and accessories may require modifications or additions to ensure compliance with the local regulations of those countries.

Hydraulic System/Steering (continued)		724 P-TIER Z-BAR / HIGH-LIFT	
Hydraulic Cycle Times	Z-Bar	High-Lift	
Raise	5.3 sec.	5.3 sec.	
Dump	1.4 sec.	1.4 sec.	
Lower (power down)	3.8 sec.	4.0 sec.	
Total	10.5 sec.	10.7 sec.	
Bucket Capacity Range			
Bucket Type			
Pin-On	3.2–3.8 m ³ (4.25–5.0 cu. yd.)		
Coupler	3.1–3.8 m ³ (4.0–5.0 cu. yd.)		
Dimensions and Specifications With Pin-On Bucket With Bolt-On Edge			

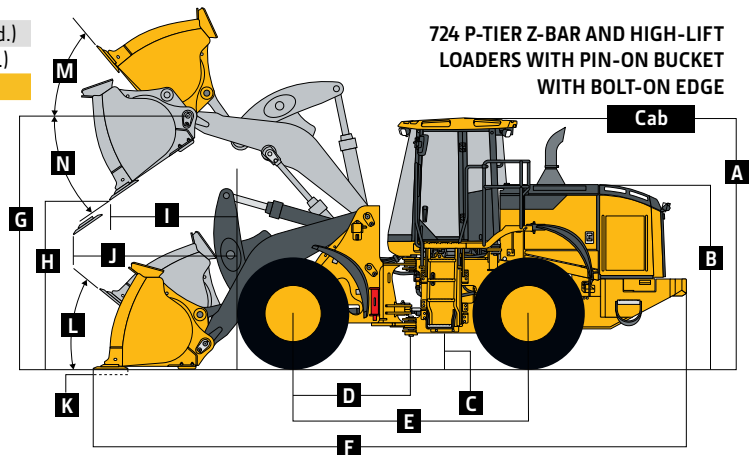

	Z-Bar	Z-Bar	High-Lift	High-Lift
Dimensions With Bucket With Bolt-On Edge (illustration above right)	3.6-m ³ (4.75 cu. yd.) <i>enhanced performance</i>	3.8-m ³ (5.0 cu. yd.) <i>enhanced performance</i>	3.4-m ³ (4.5 cu. yd.) <i>enhanced performance</i>	3.6-m ³ (4.75 cu. yd.) <i>enhanced performance</i>
A Height to Top of Cab	3.45 m (11 ft. 4 in.)	3.45 m (11 ft. 4 in.)	3.45 m (11 ft. 4 in.)	3.45 m (11 ft. 4 in.)
B Hood Height	2.51 m (8 ft. 3 in.)	2.51 m (8 ft. 3 in.)	2.51 m (8 ft. 3 in.)	2.51 m (8 ft. 3 in.)
C Ground Clearance	386 mm (15.2 in.)	386 mm (15.2 in.)	386 mm (15.2 in.)	386 mm (15.2 in.)
D Length From Centerline to Front Axle	1.66 m (5 ft. 5 in.)	1.66 m (5 ft. 5 in.)	1.66 m (5 ft. 5 in.)	1.66 m (5 ft. 5 in.)
E Wheelbase	3.31 m (10 ft. 10 in.)	3.31 m (10 ft. 10 in.)	3.31 m (10 ft. 10 in.)	3.31 m (10 ft. 10 in.)
F Overall Length, Bucket on Ground	8.42 m (27 ft. 8 in.)	8.47 m (27 ft. 9 in.)	8.77 m (28 ft. 9 in.)	8.82 m (28 ft. 11 in.)
G Height to Hinge Pin, Fully Raised	4.16 m (13 ft. 8 in.)	4.16 m (13 ft. 8 in.)	4.50 m (14 ft. 9 in.)	4.50 m (14 ft. 9 in.)
H Dump Clearance, 45 deg., Full Height	2.87 m (9 ft. 5 in.)	2.84 m (9 ft. 4 in.)	3.25 m (10 ft. 8 in.)	3.21 m (10 ft. 7 in.)
I Reach, 45-deg. Dump, Full Height	1.12 m (3 ft. 8 in.)	1.15 m (3 ft. 9 in.)	1.20 m (3 ft. 11 in.)	1.24 m (4 ft. 1 in.)
J Reach, 45-deg. Dump, 2.13-m (7 ft. 0 in.) Clearance	1.68 m (5 ft. 6 in.)	1.70 m (5 ft. 7 in.)	2.04 m (6 ft. 8 in.)	2.06 m (6 ft. 9 in.)
K Maximum Digging Depth	160 mm (6 in.)	160 mm (6 in.)	270 mm (10 in.)	270 mm (11 in.)
L Maximum Rollback at Ground Level	43 deg.	43 deg.	46 deg.	46 deg.
M Maximum Rollback, Boom Fully Raised	60 deg.	60 deg.	60 deg.	60 deg.
N Maximum Bucket Dump Angle, Fully Raised	47 deg.	47 deg.	45 deg.	45 deg.
Loader Clearance Circle, Bucket Carry Position	13.0 m (42 ft. 10 in.)	13.1 m (42 ft. 10 in.)	13.3 m (43 ft. 7 in.)	13.4 m (44 ft. 0 in.)
Specifications With Bucket With Bolt-On Edge				
Capacity, Heaped	3.6 m ³ (4.76 cu. yd.)	3.8 m ³ (5.00 cu. yd.)	3.4 m ³ (4.50 cu. yd.)	3.6 m ³ (4.76 cu. yd.)
Capacity, Struck	3.0 m ³ (3.90 cu. yd.)	3.2 m ³ (4.12 cu. yd.)	2.8 m ³ (3.68 cu. yd.)	3.0 m ³ (3.90 cu. yd.)
Bucket Weight With Bolt-On Cutting Edge	1919 kg (4,232 lb.)	1954 kg (4,308 lb.)	1880 kg (4,145 lb.)	1919 kg (4,232 lb.)
Bucket Width	3.04 m (10 ft. 0 in.)	3.04 m (10 ft. 0 in.)	3.04 m (10 ft. 0 in.)	3.04 m (10 ft. 0 in.)
Breakout Force	15 988 kg (35,248 lb.)	15 496 kg (34,163 lb.)	16 527 kg (36,436 lb.)	15,946 kg (35,155 lb.)
Tipping Load, Straight, No Tire Deflection	16 405 kg (36,167 lb.)	16 302 kg (35,940 lb.)	13 777 kg (30,373 lb.)	13 677 kg (30,153 lb.)
Tipping Load, Straight, With Tire Deflection	15 312 kg (33,757 lb.)	15 210 kg (33,532 lb.)	12 975 kg (28,605 lb.)	12 876 kg (28,387 lb.)
Tipping Load, 40-deg. Full Turn, No Tire Deflection	14 204 kg (31,315 lb.)	14 109 kg (31,106 lb.)	11 870 kg (26,168 lb.)	11 777 kg (25,964 lb.)
Tipping Load, 40-deg. Full Turn, With Tire Deflection	12 843 kg (28,314 lb.)	12 747 kg (28,102 lb.)	10 854 kg (23,929 lb.)	10 761 kg (23,724 lb.)
Rated Operating Load, 50% Full-Turn Tipping Load, No Tire Deflection (conforms to ISO 14397-1)*	7102 kg (15,657 lb.)	7055 kg (15,553 lb.)	5935 kg (13,084 lb.)	5889 kg (12,982 lb.)
Rated Operating Load, 50% Full-Turn Tipping Load, With Tire Deflection (conforms to ISO 14397-1)*	6422 kg (14,157 lb.)	6374 kg (14,051 lb.)	5427 kg (11,964 lb.)	5381 kg (11,862 lb.)
Operating Weight	19 825 kg (43,707 lb.)	19 859 kg (43,783 lb.)	19 945 kg (43,971 lb.)	19 984 kg (44,058 lb.)
<i>Loader operating information is based on machine with identified linkage and standard equipment, PowerTech PSS 6090 (EPA Final Tier 4/EU Stage V) engine, ROPS cab, rear cast bumper/counterweight, transmission side-frame guards, bottom guards, standard tires, full fuel tank, and 79-kg (175 lb.) operator. This information is affected by changes in tires, ballast, and different attachments, and assumes no tire deflection per the standard ISO 14397-1 section 5.</i>				

*Rated operating capacity based on Deere attachments only.

724 P-TIER

While general information, pictures, and descriptions are provided, some illustrations and text may include product options and accessories NOT AVAILABLE in all regions, and in some countries products and accessories may require modifications or additions to ensure compliance with the local regulations of those countries.

Dimensions and Specifications With Hi-Vis Coupler and Hook-On Bucket With Bolt-On Edge

724 P-TIER Z-BAR / HIGH-LIFT

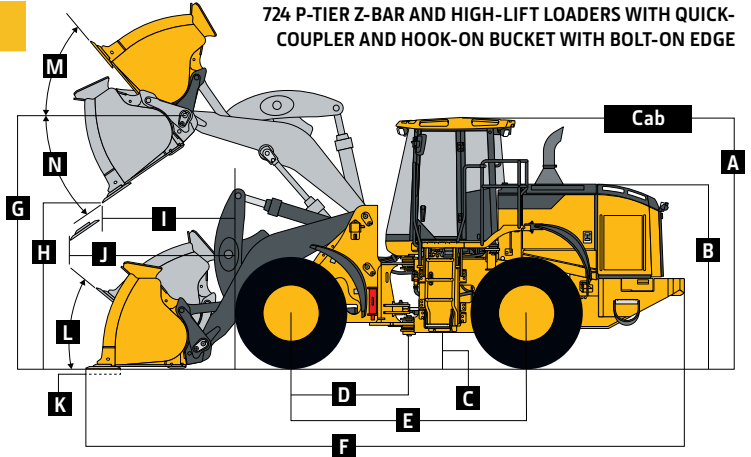

	Z-Bar	Z-Bar	High-Lift	High-Lift
Dimensions With Bucket With Bolt-On Edge (illustration above right)	3.4-m ³ (4.5 cu. yd.) <i>enhanced performance</i>	3.6-m ³ (4.75 cu. yd.) <i>enhanced performance</i>	3.2-m ³ (4.25 cu. yd.) <i>enhanced performance</i>	3.4-m ³ (4.5 cu. yd.) <i>enhanced performance</i>
A Height to Top of Cab	3.45 m (11 ft. 4 in.)	3.45 m (11 ft. 4 in.)	3.45 m (11 ft. 4 in.)	3.45 m (11 ft. 4 in.)
B Hood Height	2.51 m (8 ft. 3 in.)	2.51 m (8 ft. 3 in.)	2.51 m (8 ft. 3 in.)	2.51 m (8 ft. 3 in.)
C Ground Clearance	386 mm (15.2 in.)	386 mm (15.2 in.)	386 mm (15.2 in.)	386 mm (15.2 in.)
D Length From Centerline to Front Axle	1.66 m (5 ft. 5 in.)	1.66 m (5 ft. 5 in.)	1.66 m (5 ft. 5 in.)	1.66 m (5 ft. 5 in.)
E Wheelbase	3.31 m (10 ft. 10 in.)	3.31 m (10 ft. 10 in.)	3.31 m (10 ft. 10 in.)	3.31 m (10 ft. 10 in.)
F Overall Length, Bucket on Ground	8.46 m (27 ft. 9 in.)	8.51 m (27 ft. 11 in.)	8.82 m (28 ft. 11 in.)	8.86 m (29 ft. 1 in.)
G Height to Hinge Pin, Fully Raised	4.16 m (13 ft. 8 in.)	4.16 m (13 ft. 8 in.)	4.50 m (14 ft. 9 in.)	4.50 m (14 ft. 9 in.)
H Dump Clearance, 45 deg., Full Height	2.85 m (9 ft. 4 in.)	2.81 m (9 ft. 3 in.)	3.22 m (10 ft. 7 in.)	3.19 m (10 ft. 6 in.)
I Reach, 45-deg. Dump, Full Height	1.15 m (3 ft. 9 in.)	1.18 m (3 ft. 10 in.)	1.24 m (4 ft. 1 in.)	1.27 m (4 ft. 2 in.)
J Reach, 45-deg. Dump, 2.13-m (7 ft. 0 in.) Clearance	1.70 m (5 ft. 7 in.)	1.71 m (5 ft. 7 in.)	2.06 m (6 ft. 9 in.)	2.08 m (6 ft. 10 in.)
K Maximum Digging Depth	150 mm (6 in.)	160 mm (6 in.)	270 mm (10 in.)	270 mm (11 in.)
L Maximum Rollback at Ground Level	43 deg.	43 deg.	45 deg.	45 deg.
M Maximum Rollback, Boom Fully Raised	60 deg.	60 deg.	60 deg.	60 deg.
N Maximum Bucket Dump Angle, Fully Raised	47 deg.	47 deg.	45 deg.	45 deg.
Loader Clearance Circle, Bucket Carry Position	131 m (42 ft. 10 in.)	131 m (42 ft. 11 in.)	13.5 m (44 ft. 4 in.)	13.5 m (44 ft. 4 in.)
Specifications With Bucket With Bolt-On Edge				
Capacity, Heaped	3.5 m ³ (4.51 cu. yd.)	3.6 m ³ (4.76 cu. yd.)	3.3 m ³ (4.26 cu. yd.)	3.5 m ³ (4.51 cu. yd.)
Capacity, Struck	2.8 m ³ (3.70 cu. yd.)	3.0 m ³ (3.91 cu. yd.)	2.7 m ³ (3.48 cu. yd.)	2.8 m ³ (3.70 cu. yd.)
Bucket Weight With Bolt-On Cutting Edge	1737 kg (3,829 lb.)	1774 kg (3,911 lb.)	1695 kg (3,737 lb.)	1737 kg (3,829 lb.)
Bucket Width	3.04 m (10 ft. 0 in.)	3.04 m (10 ft. 0 in.)	3.04 m (10 ft. 0 in.)	3.04 m (10 ft. 0 in.)
Breakout Force	15 478 kg (34,123 lb.)	14 977 kg (33,018 lb.)	15 900 kg (35,053 lb.)	15 437 kg (34,032 lb.)
Tipping Load, Straight, No Tire Deflection	15 644 kg (34,489 lb.)	15 537 kg (34,254 lb.)	13 089 kg (28,855 lb.)	13 009 kg (28,679 lb.)
Tipping Load, Straight, With Tire Deflection	14 589 kg (32,163 lb.)	14 484 kg (31,932 lb.)	12 312 kg (27,143 lb.)	12 231 kg (26,965 lb.)
Tipping Load, 40-deg. Full Turn, No Tire Deflection	13 493 kg (29,746 lb.)	13 395 kg (29,530 lb.)	11 221 kg (24,738 lb.)	11 146 kg (24,572 lb.)
Tipping Load, 40-deg. Full Turn, With Tire Deflection	12 177 kg (26,846 lb.)	12 081 kg (26,634 lb.)	10 236 kg (22,566 lb.)	10 158 kg (22,395 lb.)
Rated Operating Load, 50% Full-Turn Tipping Load, No Tire Deflection (conforms to ISO 14397-1)*	6746 kg (14,873 lb.)	6697 kg (14,765 lb.)	5610 kg (12,369 lb.)	5573 kg (12,286 lb.)
Rated Operating Load, 50% Full-Turn Tipping Load, With Tire Deflection (conforms to ISO 14397-1)*	6089 kg (13,423 lb.)	6041 kg (13,317 lb.)	5118 kg (11,283 lb.)	5079 kg (11,197 lb.)
Operating Weight	20 299 kg (44,753 lb.)	20 335 kg (44,830 lb.)	20 417 kg (45,012 lb.)	20 459 kg (45,103 lb.)
<i>Loader operating information is based on machine with identified linkage and standard equipment, PowerTech PSS 6090 (EPA Final Tier 4/EU Stage V) engine, ROPS cab, rear cast bumper/counterweight, transmission side-frame guards, bottom guards, standard tires, full fuel tank, and 79-kg (175 lb.) operator. This information is affected by changes in tires, ballast, and different attachments, and assumes no tire deflection per the standard ISO 14397-1 section 5.</i>				
<i>*Rated operating capacity based on Deere attachments only.</i>				

Dimensions and Specifications With Hi-Vis Coupler and Construction Forks

	Z-Bar	Z-Bar	High-Lift	High-Lift
Dimensions With Forks (illustration at top of next page)	1.52-m (60 in.) tine length	1.83-m (72 in.) tine length	1.52-m (60 in.) tine length	1.83-m (72 in.) tine length
A Height to Top of Cab	3.45 m (11 ft. 4 in.)	3.45 m (11 ft. 4 in.)	3.45 m (11 ft. 4 in.)	3.45 m (11 ft. 4 in.)
B Hood Height	2.51 m (8 ft. 3 in.)	2.51 m (8 ft. 3 in.)	2.51 m (8 ft. 3 in.)	2.51 m (8 ft. 3 in.)
C Ground Clearance	386 mm (15.2 in.)	386 mm (15.2 in.)	386 mm (15.2 in.)	386 mm (15.2 in.)
D Length From Centerline to Front Axle	1.66 m (5 ft. 5 in.)	1.66 m (5 ft. 5 in.)	1.66 m (5 ft. 5 in.)	1.66 m (5 ft. 5 in.)
E Wheelbase	3.31 m (10 ft. 10 in.)	3.31 m (10 ft. 10 in.)	3.31 m (10 ft. 10 in.)	3.31 m (10 ft. 10 in.)
F Overall Length, Forks on Ground	9.00 m (29 ft. 6 in.)	9.30 m (30 ft. 6 in.)	9.41 m (30 ft. 10 in.)	9.71 m (31 ft. 10 in.)
G Height to Hinge Pin, Fully Raised	4.16 m (13 ft. 8 in.)	4.16 m (13 ft. 8 in.)	4.50 m (14 ft. 9 in.)	4.50 m (14 ft. 9 in.)
H Reach, Fully Raised	810 mm (32 in.)	810 mm (32 in.)	930 mm (3 ft. 1 in.)	930 mm (3 ft. 1 in.)
I Fork Height, Fully Raised	3.85 m (12 ft. 7 in.)	3.85 m (12 ft. 7 in.)	4.19 m (13 ft. 9 in.)	4.19 m (13 ft. 9 in.)
J Maximum Reach, Fork Level	1.72 m (5 ft. 8 in.)	1.72 m (5 ft. 8 in.)	2.05 m (6 ft. 9 in.)	2.05 m (6 ft. 9 in.)
K Fork Height, Maximum Reach	1.74 m (5 ft. 9 in.)	1.74 m (5 ft. 9 in.)	1.74 m (5 ft. 9 in.)	1.74 m (5 ft. 9 in.)
L Reach, Ground Level	1.15 m (3 ft. 9 in.)	1.15 m (3 ft. 9 in.)	1.56 m (5 ft. 1 in.)	1.56 m (5 ft. 1 in.)
M Depth Below Ground	110 mm (4 in.)	110 mm (4 in.)	220 mm (9 in.)	220 mm (9 in.)
N Tine Length	1.52 m (60 in.)	1.83 m (72 in.)	1.52 m (60 in.)	1.83 m (72 in.)
O Load Position, 50% Tine Length	760 mm (30 in.)	910 mm (36 in.)	760 mm (30 in.)	910 mm (36 in.)

While general information, pictures, and descriptions are provided, some illustrations and text may include product options and accessories NOT AVAILABLE in all regions, and in some countries products and accessories may require modifications or additions to ensure compliance with the local regulations of those countries.

724 P-TIER

Dimensions and Specifications With Hi-Vis Coupler and Construction Forks (continued)

724 P-TIER Z-BAR / HIGH-LIFT

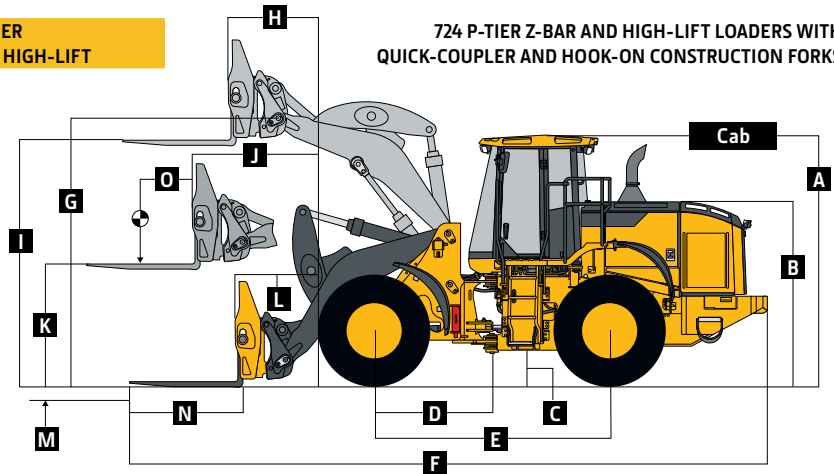

724 P-TIER Z-BAR AND HIGH-LIFT LOADERS WITH QUICK-COUPLER AND HOOK-ON CONSTRUCTION FORKS

	Z-Bar	Z-Bar	High-Lift	High-Lift
Specifications With Forks (illustration above right)				
Tipping Load, Straight, No Tire Deflection	10 998 kg (24,247 lb.)	10 441 kg (23,018 lb.)	9653 kg (21,280 lb.)	9194 kg (20,270 lb.)
Tipping Load, Straight, With Tire Deflection	10 668 kg (23,519 lb.)	10 137 kg (22,348 lb.)	9372 kg (20,662 lb.)	8931 kg (19,689 lb.)
Tipping Load, 40-deg. Full Turn, No Tire Deflection	9528 kg (21,006 lb.)	9036 kg (19,921 lb.)	8320 kg (18,342 lb.)	7915 kg (17,450 lb.)
Tipping Load, 40-deg. Full Turn, With Tire Deflection	9090 kg (20,040 lb.)	8631 kg (19,028 lb.)	7950 kg (17,527 lb.)	7569 kg (16,687 lb.)
Rated Operating Load, 50% Full-Turn Tipping Load, With Tire Deflection (conforms to ISO 14397-1 and SAE J1197)*	4545 kg (10,020 lb.)	4316 kg (9,514 lb.)	3975 kg (8,763 lb.)	3785 kg (8,343 lb.)
Rated Operating Load, Rough Terrain, 60% Full-Turn Tipping Load, With Tire Deflection (conforms to EN474-3)*	5454 kg (12,024 lb.)	5179 kg (11,417 lb.)	4770 kg (10,516 lb.)	4541 kg (10,012 lb.)
Rated Operating Load, Firm and Level Ground, 80% Full-Turn Tipping Load, With Tire Deflection (conforms to EN474-3)*	7272 kg (16,032 lb.)	6905 kg (15,222 lb.)	6360 kg (14,021 lb.)	6055 kg (13,349 lb.)
Operating Weight	19 670 kg (43,366 lb.)	19 731 kg (43,499 lb.)	19 830 kg (43,717 lb.)	19 890 kg (43,849 lb.)

Loader operating information is based on machine with identified linkage and standard equipment, PowerTech PSS 6090 (EPA Final Tier 4/EU Stage V) engine, ROPS cab, rear cast bumper/counterweight, transmission side-frame guards, bottom guards, standard tires, full fuel tank, and 79-kg (175 lb.) operator. This information is affected by changes in tires, ballast, and different attachments, and assumes no tire deflection per the standard ISO 14397-1 section 5.

*Rated operating capacity based on Deere attachments only.

Adjustments to Operating Weights and Tipping Loads With Buckets

Adjustments to operating weights, tipping loads, and tires are based on Z-Bar machine with pin-on 3.6-m³ (4.75 cu. yd.) enhanced-performance bucket with bolt-on cutting edge, ROPS cab, rear cast bumper/counterweight, transmission side-frame guards, bottom guards, standard tires, full fuel tank, and 79-kg (175 lb.) operator*

Add (+) or deduct (-) kg (lb.) as indicated for loaders with 3-piece rims	Operating Weight	Tipping Load,		Tread Width	Width Over Tires	Vertical Height
		Straight	40-deg. Full Turn			
Michelin 23.5 R 25, 1 Star L-3	0 kg (0 lb.)	0 kg (0 lb.)	0 kg (0 lb.)	0 mm (0 in.)	0 mm (0 in.)	0 mm (0 in.)
Bridgestone 23.5 R 25, 1 Star L-3	+101 kg (+223 lb.)	+77 kg (+170 lb.)	+68 kg (+150 lb.)	-3 mm (-0.1 in.)	+15 mm (+0.6 in.)	+39 mm (+1.5 in.)
Titan 23.5-25, 20 PR L-3	-271 kg (-597 lb.)	-206 kg (-455 lb.)	-182 kg (-401 lb.)	-3 mm (-0.1 in.)	+33 mm (+1.3 in.)	+29 mm (+1.1 in.)
Titan 725/70-25, 16-Ply L-4T (Logger Style) ^{§8}	+359 kg (+792 lb.)	+284 kg (+627 lb.)	+251 kg (+554 lb.)	+31 mm (+1.2 in.)	+116 mm (+4.6 in.)	+78 mm (+3.1 in.)
Michelin 750/65 R 25, 1 Star L-3T ^{§8}	+715 kg (+1,577 lb.)	+556 kg (+1,225 lb.)	+491 kg (+1,081 lb.)	+31 mm (+1.2 in.)	+137 mm (+5.4 in.)	+42 mm (+1.7 in.)

*May change based on vehicle configuration, weight, or tire-pressure adjustments.

[†]Equipped with 5-piece heavy-duty rims.

[§]CaCl₂ not recommended.

[§]Requires 9-deg. rear axle stops.

Bucket Selection Guides

LOOSE MATERIALS	kg/m ³	lb./cu. yd.	LOOSE MATERIALS	kg/m ³	lb./cu. yd.
Chips, pulpwood	288	486	Limestone, coarse, sized	1570	2,646
Cinders (coal, ashes, clinkers)	673	1,134	Limestone, mixed sizes	1682	2,835
Clay and gravel, dry	1602	2,700	Limestone, pulverized or crushed	1362	2,295
Clay, compact, solid	1746	2,943	Sand, damp	2083	3,510
Clay, dry in lumps/loose	1009	1,701	Sand, dry	1762	2,970
Clay, excavated in water	1282	2,160	Sand, voids, full of water	2083	3,510
Coal, anthracite, broken, loose	865	1,458	Sandstone, quarried	1314	2,214
Coal, bituminous, moderately wet	801	1,350	Shale, broken crushed	1362	2,295
Earth, common loam, dry	1218	2,052	Slag, furnace granulated	1955	3,294
Earth, mud, packed	1843	3,105	Stone or gravel, 37.5 to 87.5-mm (1.5 to 3.5") size	1442	2,430
Granite, broken	1538	2,592	Stone or gravel, 18.75-mm (0.75") size	1602	2,700
Gypsum	2275	3,834			

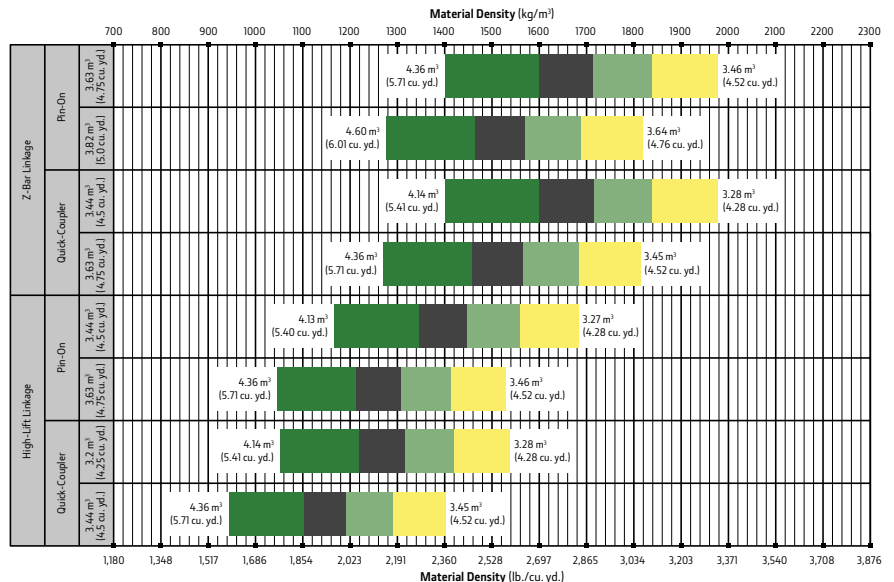
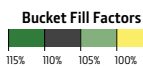

Additional equipment

Key: ● Standard ▲ Optional or special

See your John Deere dealer for further information.

724 P Engine

- Wet-sleeve cylinder liners
- Programmable auto-idle and auto shutdown
- Selected idle adjustment from 900–1,250 rpm
- Starter excessive-cranking protection
- Automatic engine cool-down timer
- Automatic derating for exceeded system temperatures
- Serpentine drive belt for automatic tensioner
- Electrical fuel-priming pump
- Dual-stage fuel filter and water separator
- 500-hour vertical spin-on oil filter
- ▲ Engine-compartment light
- ▲ Chrome exhaust stack
- ▲ Automatic ether starting aid (recommended for cold starts below –12 deg. C [10 deg. F])
- ▲ Engine-block heater (recommended for cold starts below –23 deg. C [–10 deg. F])
- ▲ Centrifugal engine air pre-cleaner
- ▲ Throttle lock

Powertrain

- Clutch cutoff with 4 operator settings: Automatic, level ground, small slope, or steep slope
- Programmable maximum high gear
- Clutch calibration engaged from monitor
- 2,000-hour vertical spin-on transmission filter
- Transmission fill tube and sight gauge
- Transmission diagnostic ports
- ▲ 4-speed transmission with non-lockup torque converter
- 5-speed transmission with lockup torque converter
- Front locking differential
- ▲ Rear locking differential
- Brake retractors and adjusters
- ▲ Automatic differential lock
- Axle oil temperature sensing
- ▲ Wheel-spin control

724 P Quad-Cool™ Cooling System

- Heavy-duty, trash-resistant radiator and high-ambient cooling package
- 2-side access to all coolers
- Isolated from engine compartment
- Engine radiator
- Engine oil cooler
- Hydraulic oil cooler (oil to air)
- Transmission oil cooler (oil to air)
- Charge air cooler (air to air)
- Fuel cooler
- Coolant recovery tank
- Antifreeze, –37 deg. C (–34 deg. F)
- Cool-on-demand, hydraulically driven, swing-out fan
- Enclosed fan safety guard
- ▲ Automatic reversing fan drive
- Axle and service-brake coolers

Hydraulics

- Electrohydraulic (EH) controls with soft stops and adjustable settings
- In-cab adjustable automatic return-to-dig bucket positioner
- In-cab adjustable automatic boom-height kickout/return to carry
- Reservoir with sight gauge and fill strainer
- Hydraulic diagnostic ports
- 4,000-hour in-tank filter
- 2 function — joystick with F-N-R
- ▲ 2 function — 2-lever fingertip controls and steering column F-N-R
- ▲ 3 function — joystick with F-N-R and integrated 3rd-function roller
- ▲ 3 function — 3-lever fingertip controls and steering column F-N-R
- ▲ 4 function — joystick with F-N-R and integrated 3rd/4th-function rollers
- Programmable multifunction buttons (2)
- Adjustable and continuous hydraulic-flow settings
- Programmable attachment settings
- Ride control, automatic with monitor-adjustable speed settings
- ▲ Hydraulic control system for quick-coupler locking pins
- ▲ Hydrau™ XR cold-temperature hydraulic fluid recommended below –25 deg. C (–13 deg. F)

724 P Steering Systems

- Conventional steering wheel with spinner knob
- ▲ Joystick steering (including conventional steering column) with gearshift, F-N-R, and horn
- ▲ Secondary steering

Electrical

- Solid-state electrical power-distribution system
- Lockable master electrical-disconnect switch
- Battery-terminal safety covers
- By-pass start safety cover at starter
- Remote jump-start access in battery box
- Pre-wired for beacon/strobe light
- Lights: Halogen driving lights with guards (2) / Front (4), rear cab (2), and rear grille (2) work lights / LED front turn signals and flashers / LED stop- and taillights
- ▲ Premium LED light package (all exterior lights are heavy-duty LED)
- Programmable courtesy lights
- Horn, electric
- Reverse warning alarm
- Multifunction/multi-language 178-mm (7 in.) LCD color monitor includes: Digital instruments — Analog display (hydraulic oil temperature, engine coolant temperature, transmission oil temperature, and engine oil pressure) / Digital display (engine rpm, transmission gear/direction indicator, hour meter, fuel level, diesel exhaust fluid (DEF) level, speedometer, odometer, and average fuel consumption)
- ▲ Multifunction/multi-language 127-mm (5 in.) LCD color monitor includes: Digital instruments — Analog display (hydraulic oil temperature, engine coolant temperature, transmission oil temperature, and engine oil pressure) / Digital display (engine rpm, transmission gear/direction indicator, hour meter, fuel level, DEF level, speedometer, odometer, and average fuel consumption)
- Integrated cycle counter with 5 categories

While general information, pictures, and descriptions are provided, some illustrations and text may include product options and accessories NOT AVAILABLE in all regions, and in some countries products and accessories may require modifications or additions to ensure compliance with the local regulations of those countries.

Net engine power is with standard equipment including air cleaner, exhaust system, alternator, and cooling fan at test conditions per ISO 9249. No derating is required up to 3050-m (10,000 ft.) altitude. Specifications and design subject to change without notice. Specifications with the exception of bucket capacity are in accordance with all applicable ISO standards. Except where otherwise noted, these specifications are based on a unit with applicable linkage and standard equipment, ROPS cab, rear cast bumper/counterweight, transmission side-frame guards, bottom guards, standard tires, full fuel tank, and 79-kg (175 lb.) operator.

Additional equipment *(cont.)*

Key: ● Standard ▲ Optional or special

See your John Deere dealer for further information.

724 P Electrical *(continued)*

- Indicator lights: Standard and selected options / Amber caution and red stop
- Operator-warning messages
- Built-in diagnostics: Diagnostic-code details / Sensor values / Calibrations / Individual circuit tester
- ▲ Electrical corrosion-prevention package
- Standard AM/FM/Weather-Band (WB) radio with remote auxiliary port
- ▲ Premium AM/FM/WB radio with Bluetooth®, remote auxiliary port, and remote USB port (premium cab only)
- 24- to 12-volt, 8-amp converter and cab power ports (3)
- ▲ 24- to 12-volt, 15- or 30-amp converter and cab power ports (3)

Operator's Station

- Standard cab with air conditioning/heater (ROPS/FOPS Level 1, isolation mounted)
- ▲ Premium cab with air conditioning/heater (ROPS/FOPS Level 1, isolation mounted)
- ▲ Automatic temperature control (premium cab only)
- Rear window defrost vent
- Keyless start with multiple security modes
- Sealed-switch module with function indicators
- Seat with backrest extension, deep foam, fabric cover, and adjustable air suspension
- ▲ Premium seat with high-wide back-and-headrest extension, heated and ventilated, leather/fabric cover, and adjustable heavy-duty air suspension
- Hydraulic controls integrated to seat
- High-visibility, bright-orange seat belt, 76 mm (3 in.), with retractor
- ▲ Seat-belt minder monitoring with JDLink™ and seat-belt indicator beacon
- Cup holder and cup/Thermos® holder with retaining strap
- Lunch-box/cooler holder with tie-down brackets

724 P Operator's Station *(continued)*

- Coat hook
- LED dome and reading light
- Rubber floor mat
- Dual-tilt steering column
- Operator's manual storage compartment
- Outside (2) and inside (1) rearview mirrors
- ▲ Heated outside mirrors with convex lens
- ▲ In-cab adjustable heated outside mirrors with convex lens (premium cab only)
- Left-side operator-station access
- Fall-arrest system anchor points tested to 2268 kg (5,000 lb.) on front of cab
- Slip-resistant steps and ergonomic handholds
- Pull-down front sun visor
- Front and rear intermittent windshield wipers and washers
- ▲ Powered cab air pre-cleaner
- ▲ Beacon bracket only
- ▲ Beacon bracket with strobe beacon
- Rearview camera
- ▲ Rearview camera with radar object-detection system
- ▲ Dedicated 178-mm (7 in.) rear camera display
- ▲ Advanced rear object-detection system
- ▲ Advanced vision system
- Payload scale ready
- ▲ SmartWeigh™ ready + trial
- ▲ SmartWeigh
- ▲ Fire extinguisher

Loader Linkage

- Z-Bar loader linkage (parallel lift)
- ▲ High-Lift Z-Bar loader linkage (parallel lift)

Buckets and Attachments

- ▲ Full line of Deere pin-on buckets, coupler buckets, and forks
- ▲ John Deere hydraulic coupler that accepts JRB-pattern attachments
- ▲ Hi-Vis hydraulic coupler that accepts Euro-pattern attachments (ISO)

724 P Overall Vehicle

- JDLink wireless communication system (available in specific countries; see your dealer for details)
- NeverGrease™ rear-axle oscillation
- Front and rear tie-downs
- Rear cast bumper/counterweight with rear hitch and locking pin
- Articulation locking bar
- Loader boom service locking bar
- 40-deg. steering articulation to each side with rubber-cushion stops on frame
- Vandal protection with lockable engine enclosures, right counterweight storage, and filler access for radiator/fuel/DEF/hydraulic transmission
- Left-side service steps and handholds
- ▲ Right-side service steps and handrails
- Storage compartment
- Fuel-tank fill strainer
- Heavy-duty fuel-tank guard
- Ground-level fuel and DEF fill
- Same-side ground-level daily servicing
- 23.5R25 tires on 3-piece rims
- ▲ 23.5R25 tires on 5-piece rims
- ▲ Tire-pressure monitoring system
- ▲ Waste handler (Z-Bar and High-Lift)
- Environmental drains and sample ports for engine, transmission, hydraulic oils, and engine coolant
- ▲ Quick fluid service (engine, transmission, hydraulic oils, and engine coolant)
- ▲ Fast-fuel system
- Fenders, front narrow
- ▲ Fenders, front full width
- ▲ Fenders, front and rear full width
- ▲ Fenders, front and rear full width with mud flaps
- ▲ Less wheels and tires with axle stops
- ▲ Rims less tires
- ▲ Transmission side-frame and bottom guards
- ▲ Special guarding for waste applications
- ▲ Lift eyes
- ▲ License-plate bracket and light

While general information, pictures, and descriptions are provided, some illustrations and text may include product options and accessories NOT AVAILABLE in all regions, and in some countries products and accessories may require modifications or additions to ensure compliance with the local regulations of those countries.

Net engine power is with standard equipment including air cleaner, exhaust system, alternator, and cooling fan at test conditions per ISO 9249. No derating is required up to 3050-m (10,000 ft.) altitude. Specifications and design subject to change without notice. Specifications with the exception of bucket capacity are in accordance with all applicable ISO standards. Except where otherwise noted, these specifications are based on a unit with applicable linkage and standard equipment, ROPS cab, rear cast bumper/counterweight, transmission side-frame guards, bottom guards, standard tires, full fuel tank, and 79-kg (175 lb.) operator.



MW724PAU (23-03)



JOHN DEERE