

K-SERIES

146–304 HP WASTE HANDLERS



JOHN DEERE





Haste moves waste.

If yours is a vast wasteland, our K-Series are your kind of waste handlers. These production machines come fully fortified to tackle tough transfer-station tasks, shift after shift. An innovative Quad-Cool™ system with proportional fan ensures that everything keeps cool. Extensive guarding minimizes debris buildup and helps keep close encounters with obstacles from slowing you down. And a solid-state electrical distribution center, durable sealed-switch module, and state-of-the-art diagnostic multifunction monitor further boost uptime and productivity. That's just the beginning. Read on to learn all the ways K-Series Waste Handlers help take out the trash.



Unique Quad-Cool design helps keep our loaders cool in grueling conditions.

John Deere turbocharged Tier 3 diesels deliver impressive torque reserves up to 55 percent (624K/644K). For pull-through power when the going gets tough.

Heavy-duty waste-handler buckets range from four to eight cubic yards. Third-function hydraulic valve is available for use with grapple buckets.

Optional high-lift booms increase dump height so you can move materials and push productivity to even greater heights.

Choose the axles that are right for you. Hydraulic front differential lock and conventional rear is standard; front and rear hydraulic differentials are available. Heavy-duty wide axles are standard on the 744K.

Hard work made easier.

From the convenient controls that let you customize machine operation, to the comfortable fully adjustable armchair seat — the K-Series Loaders have everything your operators need to stay alert and productive. All-around visibility is exceptional, offering clear sight lines of the work area and obstacles around you. And an efficient HVAC system helps keep the view clear, the environment comfortable. A sealed-switch module allows convenient, fingertip control of multiple machine operations. Up front, a state-of-the-art multifunction monitor with easy-to-read gauges and messaging provides vital operating info at a glance.



Standard air-ride armchair seat adjusts multiple ways for extra comfort.

Independently adjustable louvers and defrosters provide effective airflow to help keep the glass clear and pressurized cab comfortable. Activated-carbon fresh-air filter reduces odors.

Choose either joystick or two-lever pilot-operated control. John Deere PowerShift™ torque-converter transmission employs Smart-Shift™ technology to ensure smooth-as-silk gear changes.

Responsive steering and full 80-degree articulation increase maneuverability in tight quarters — for fast cycles and fewer three-point turns.

Return-to-carry, boom height kick-out, and return-to-dig are set with just a touch of a button. These advantages help speed production in repetitive loading applications.

Industry-leading 360-degree visibility gives a clear view of the work ahead and obstacles around you.



1. Advanced, multi-language monitor with analog gauges and LED indicators provides:

Vital and general operating information including transmission mode, gear, engine rpms, and ground speed.

Diagnostic readings of most sensors and switches, enabling technicians to quickly troubleshoot problems.

Customized machine settings that allow the operator to match the loader's operating characteristics to specific applications by preselecting transmission functions such as Quick-Shift and Auto-to-1st for maximum productivity.

2. Conveniently positioned switch module helps reduce operator fatigue with clearly visible backlit and sealed controls.

3. In-cab lockable master switch makes it easy to disconnect electrical power.



Keep cool under pressure.

You know the drill. Debris works its way into everything — clinging to intake screens, plugging coolers, filling engine compartments, and causing overheating. But these waste handlers are built to work long and hard without breaking a sweat. Their unique Quad-Cool™ system places everything in an easy-to-clean package, effectively isolating critical cooling components from engine heat. What's more, a hydraulically driven fan automatically reverses to eject buildup. For cool-running efficiency, regardless of what's under-foot. Or in the air.



1. Fan automatically reverses to help eliminate cooler-clogging buildup. Or select reversing through the monitor as required.

2. Quad-Cool system places the radiator, intercooler, air-conditioner condenser, and transmission and optional axle coolers in an independent package. Outside air flows through the perforated top, side panels, and coolers, and out the rear instead of drawing air through the engine compartment, for increased efficiency and durability.



Transmission oil cooler has its own air-intake screen for more efficient cooling.

Three-millimeter perforations act as a “first filter,” preventing entry of most airborne debris. Anything that gets through the side screens easily passes through the cooler cores.

No stacked cores in these waste handlers. Both sides of all coolers are easily accessible. Plus the hinged grill and fan swing open a full 90 degrees, further simplifying cleanout.

No place for the faint of heart.

You won't have to be concerned about these waste handlers getting trashed too soon. Their rugged reliability starts with traditional John Deere durability features such as wet-sleeve diesels, inboard planetary wet-disc brakes, and heavy-duty mainframes. From the high-visibility window bars to the heavy-duty hydraulic belly pans, all vulnerable components are guarded to protect them from trash infiltration and impact damage. Helps keep the daily grind from grinding these highly productive machines, and your operation, to a halt.



1. Articulation joint shields and drive-shaft guards resist trash buildup.



2. Front window bars protect glass without obstructing all-around visibility.



3. Axle guards help protect the seals and resist refuse wrapping.



4. Extreme-duty steps are mounted in close where they're less vulnerable. Their flexible design takes abuse and comes back for more.



5. Extreme-duty front loader frame cover, lower loader frame guard, transmission side covers, and boom cylinder and hydraulic line guards give additional impact and debris resistance.



6. High-intensity halogen driving and work lights are powerful and well protected. Optional ROPS-mounted gel-filled strobe light alerts bystanders of the machine's presence.

7. Bolt-on hinged or optional hydraulic belly pans provide unmatched protection of the fuel tank and drivetrain. Hydraulic versions have built-in safety features that open and close easily for cleanout.



744K
WH

JOHN DEERE

Self-adjusting inboard wet-disc brakes run cool, clean, and unexposed to corrosive materials. Optional extreme-duty axle cooling kit helps beat the heat for long-term durability.

Sealed-switch module keeps out dust, moisture, and debris, so it virtually never wears out. Job-proven touch pad eliminates rocker switches and nearly 100 wires and unsealed connections.

Electrical distribution center employs extremely reliable circuit-board technology and solid-state switches, eliminating the need for a multitude of wiring harnesses, fuses, relays, and connections.



Get the lowdown on daily operating costs.

In addition to the enhancements that protect glass, sheet metal, and components, the K-Series Loaders are built to allow simplified maintenance. Service intervals have been extended, and same-side ground-level service points make quick work of the daily routine. Large hinged side shields open wide to provide ample access to dipsticks, vertical spin-on filters, sight gauges, and maintenance-free batteries. These, plus many other timesaving advantages, help minimize downtime and expense.





Large hinged doors open wide, providing quick and easy access to the engine and Quad-Cool system.

Hydraulically driven variable-speed fan runs only as needed to help maximize fuel efficiency and reduce noise.

Four-thousand-hour hydraulic filter change interval and large fuel tanks help maximize uptime.

Both sides of all coolers are easily accessible, for quick and easy cleanout.

Corrugated fine-mesh screen air cleaner efficiently filters the airflow.

524K WH / 544K WH

Engine	524K WH		544K WH	
Manufacturer and Model	John Deere PowerTech™ 6068H		John Deere PowerTech E 6068H	
Non-Road Emission Standards	Certified to EPA Tier 3 emissions		Certified to EPA Tier 3 emissions	
Cylinders	6		6	
Valves per Cylinder	2		2	
Displacement	414 cu. in. (6.8 L)		414 cu. in. (6.8 L)	
Net Peak Power	146 hp (110 kW) at 2,000 rpm		167 hp (125 kW) at 1,900 rpm	
Net Peak Torque	448 lb.-ft. (607 Nm) at 1,600 rpm		496 lb.-ft. (673 Nm) at 1,600 rpm	
Net Torque Rise	47%		38%	
Fuel System (electronically controlled)	High-pressure common rail		High-pressure common rail	
Lubrication	Full-flow spin-on filter and integral cooler		Full-flow spin-on filter and integral cooler	
Aspiration	Turbocharged, charge air cooled		Turbocharged, charge air cooled	
Air Cleaner	Under-hood dual-element dry type; restriction indicator in cab monitor for service			
Cooling	524K WH / 544K WH			
Fan Drive	Hydraulically driven, proportionally controlled, fan aft of coolers			
Fan Type	Blower type			
Engine Coolant Rating	-34 deg. F (-37 deg. C)			
Engine Radiator	7.5 fins per in. (water to air)			
Hydraulic Cooler	6.3 fins per in. (oil to air)			
Charge Air Cooler	6.3 fins per in. (air to air)			
Transmission Oil Cooler	6.3 fins per in. (oil to air)			
Transmission	524K WH		544K WH	
Type	Countershaft-type PowerShift™		Countershaft-type PowerShift	
Torque Converter	Single stage, single phase		Single stage, single phase	
Operator Interface	Steering-column- or joystick-mounted F-N-R and gear-select lever; quick-shift button on hydraulic lever			
Shift Control	Electronically modulated, adaptive, load and speed dependent			
Shift Modes	Manual/auto (1st-D or 2nd-D); quick-shift button with 2 selectable modes: kick-down or kick-up/down; and 3 adjustable clutch cutoff settings			
Maximum Gear	Programmable via monitor		Programmable via monitor	
Travel Speeds with 20.5-25 Tires	<i>Forward Maximum</i>	<i>Reverse Maximum</i>	<i>Forward Maximum</i>	<i>Reverse Maximum</i>
Gear 1	4.5 mph (7.2 km/h)	4.5 mph (7.2 km/h)	4.5 mph (7.2 km/h)	4.5 mph (7.2 km/h)
Gear 2	7.5 mph (12.0 km/h)	7.8 mph (12.6 km/h)	7.5 mph (12.0 km/h)	7.8 mph (12.6 km/h)
Gear 3	14.3 mph (23.0 km/h)	15.0 mph (24.1 km/h)	14.2 mph (22.8 km/h)	15.0 mph (24.1 km/h)
Gear 4	22.4 mph (36.0 km/h)	—	22.2 mph (35.7 km/h)	—
Axles/Brakes	524K WH / 544K WH			
Final Drives	Heavy-duty inboard-mounted planetary			
Differentials	Hydraulic locking front with conventional rear – standard; dual locking front and rear – optional			
Rear Axle Oscillation (stop to stop)	24 deg.			
Brakes (conform to ISO 3450)				
Service Brakes	Hydraulically actuated, inboard sun-shaft mounted, oil cooled, self-adjusting, single disc			
Parking Brake	Automatic spring applied, hydraulically released, driveline mounted, oil cooled, multi disc			



Tires/Wheels	524K WH / 544K WH			
With 20.5 x 25 Solid Rubber Tires				
Tread Width	76.8 in. (1951 mm)			
Width Over Tires	97.1 in. (2466 mm)			
Hydraulic System/Steering	524K WH		544K WH	
Pump (loader and steering)	Variable-displacement, axial-piston pump; closed-center, pressure-compensating system			
Maximum Rated Flow at 1,000 psi (6895 kPa) and 2,350 rpm	44 gpm (165 L/m)		50 gpm (189 L/m)	
System Relief Pressure, Loader and Steering	3,625 psi (24 994 kPa)		3,650 psi (25 166 kPa)	
Loader Controls	2-function valve; joystick or fingertip control; hydraulic-function enable/disable; optional 3rd- and 4th-function valve with auxiliary lever			
Steering (conforms to ISO 5010)				
Type	Power, fully hydraulic		Power, fully hydraulic	
Articulation Angle	80-deg. arc (40 deg. each direction)		80-deg. arc (40 deg. each direction)	
Hydraulic Cycle Times	<i>Standard Z-Bar</i>	<i>High-Lift Z-Bar</i>	<i>Standard Z-Bar</i>	<i>High-Lift Z-Bar</i>
Raise	6.1 sec.	6.1 sec.	5.8 sec.	5.8 sec.
Dump	1.4 sec.	1.4 sec.	1.2 sec.	1.2 sec.
Lower (float down)	3.0 sec.	3.0 sec.	3.2 sec.	3.2 sec.
Total	10.5 sec.	10.5 sec.	10.2 sec.	10.2 sec.
Turning Radius				
Measured to Centerline of Outside Tire	16 ft. 5 in. (5.00 m)		16 ft. 5 in. (5.00 m)	
Electrical System	524K WH / 544K WH			
Electrical System	24 volt with 80-amp alternator (100-amp alternator optional)			
Batteries (2 – 12 volt)	950 CCA (each)			
Serviceability				
Refill Capacities				
Fuel Tank	86 gal. (325 L)			
Cooling System	24 qt. (23 L)			
Engine Oil with Vertical Spin-On Filter	20 qt. (19 L)			
Transmission Fluid with Vertical Spin-On Filter	19.5 qt. (18.5 L)			
Axle Oil (front and rear)	18 qt. (17 L)			
Hydraulic Reservoir and Filters	24 gal. (91 L)			
Park Brake Oil (wet disc)	10 oz. (0.3 L)			
Operating Weights	524K WH		544K WH	
All configurations include waste-handler protection, 20.5 x 25 solid rubber tires, cab, full fuel tank, and 175-lb. (79 kg) operator				
	<i>Standard Z-Bar</i>	<i>High-Lift Z-Bar</i>	<i>Standard Z-Bar</i>	<i>High-Lift Z-Bar</i>
4.0-cu.-yd. (3.1 m ³) Standard-Lip Bucket	33,887 lb. (15 371 kg)	34,311 lb. (15 563 kg)	35,008 lb. (15 879 kg)	35,329 lb. (16 025 kg)
5.0-cu.-yd. (3.8 m ³) Standard-Lip Bucket	—	—	35,408 lb. (16 061 kg)	35,729 lb. (16 206 kg)

Machine Dimensions
524K WH

	<i>Standard Z-Bar</i>	<i>High-Lift Z-Bar</i>
Linkage with Pin-On Bucket		
A Height to Top of Cab and Canopy	10 ft. 10 in. (3.31 m)	10 ft. 10 in. (3.31 m)
B Ground Clearance	18 in. (0.46 m)	18 in. (0.46 m)
C Length from Centerline to Front Axle	4 ft. 9 in. (1.45 m)	4 ft. 9 in. (1.45 m)
D Wheelbase	9 ft. 7 in. (2.93 m)	9 ft. 7 in. (2.93 m)
E Dump Clearance with 4.0-cu.-yd. (3.1 m ³) Bucket	8 ft. 7 in. (2.63 m)	9 ft. 11 in. (3.03 m)
F Height to Hinge Pin, Fully Raised	12 ft. 6 in. (3.80 m)	13 ft. 8 in. (4.18 m)
G Dump Reach with 4.0-cu.-yd. (3.1 m ³) Bucket	34 in. (0.86 m)	3 ft. 3 in. (0.99 m)
H Overall Length with 4.0-cu.-yd. (3.1 m ³) Bucket	24 ft. 4 in. (7.41 m)	25 ft. 5 in. (7.75 m)
I Maximum Rollback at Ground Level	35.0 deg.	35.4 deg.
J Maximum Rollback at Full Height	51.0 deg.	45.5 deg.
K Maximum Dump Angle at Full Height	50.3 deg.	45.7 deg.
Capacity, Heaped, with Bolt-On Cutting Edge	4.0 cu. yd. (3.1 m ³)	4.0 cu. yd. (3.1 m ³)
Capacity, Struck	3.5 cu. yd. (2.7 m ³)	3.5 cu. yd. (2.7 m ³)
Breakout Force	17,701 lb. (8029 kg)	16,294 lb. (7391 kg)
Tipping Load, Straight	23,122 lb. (10 488 kg)	19,565 lb. (8875 kg)
Tipping Load, 40-deg. Full Turn	20,144 lb. (9137 kg)	16,972 lb. (7698 kg)
Bucket Weight	3,200 lb. (1451 kg)	3,200 lb. (1451 kg)
Bucket Width	8 ft. 10 in. (2.69 m)	8 ft. 10 in. (2.69 m)
Reach, 45-deg. Dump, 7-ft. (2.13 m) Clearance	4 ft. 6 in. (1.38 m)	5 ft. 6 in. (1.68 m)
Loader Clearance Circle, Bucket Carry Position	38 ft. 10 in. (11.84 m)	39 ft. 10 in. (12.15 m)

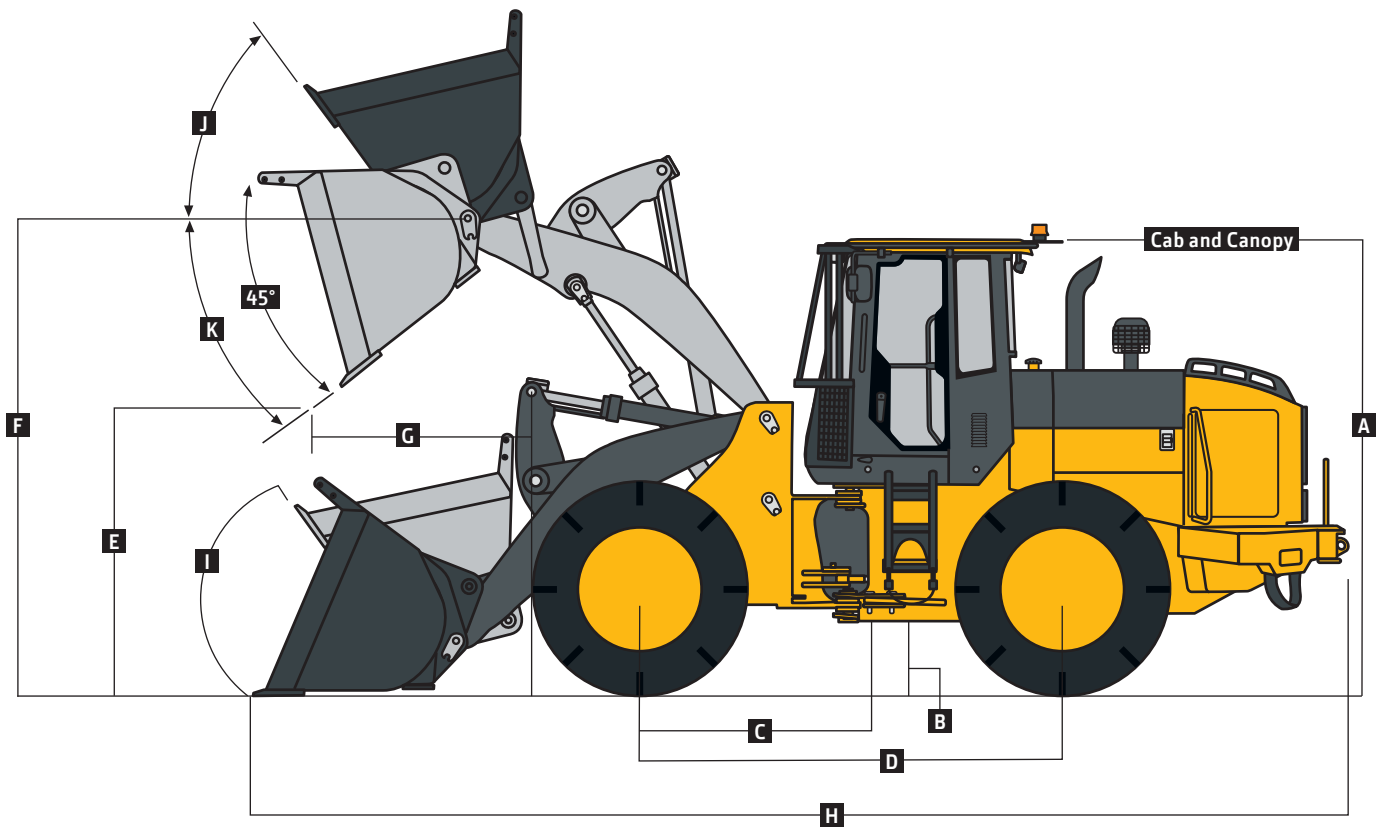

Machine Dimensions	544K WH			
Linkage with Pin-On Bucket	Standard Z-Bar		High-Lift Z-Bar	
A Height to Top of Cab and Canopy	10 ft. 10 in. (3.31 m)		10 ft. 10 in. (3.31 m)	
B Ground Clearance	18 in. (0.46 m)		18 in. (0.46 m)	
C Length from Centerline to Front Axle	4 ft. 9 in. (1.45 m)		4 ft. 9 in. (1.45 m)	
D Wheelbase	9 ft. 7 in. (2.93 m)		9 ft. 7 in. (2.93 m)	
E Dump Clearance				
With 4.0-cu.-yd. (3.1 m ³) Bucket	8 ft. 10 in. (2.69 m)		10 ft. 2 in. (3.11 m)	
With 5.0-cu.-yd. (3.8 m ³) Bucket	8 ft. 4 in. (2.55 m)		9 ft. 10 in. (2.99 m)	
F Height to Hinge Pin, Fully Raised	12 ft. 9 in. (3.88 m)		13 ft. 10 in. (4.23 m)	
G Dump Reach				
With 4.0-cu.-yd. (3.1 m ³) Bucket	33.5 in. (0.85 m)		3 ft. 2 in. (0.97 m)	
With 5.0-cu.-yd. (3.8 m ³) Bucket	3 ft. 2 in. (0.97 m)		3 ft. 7 in. (1.10 m)	
H Overall Length				
With 4.0-cu.-yd. (3.1 m ³) Bucket	24 ft. 4 in. (7.41 m)		25 ft. 5 in. (7.75 m)	
With 5.0-cu.-yd. (3.8 m ³) Bucket	24 ft. 11 in. (7.60 m)		26 ft. 0 in. (7.93 m)	
I Maximum Rollback at Ground Level	35.0 deg.		35.4 deg.	
J Maximum Rollback at Full Height	51.0 deg.		45.5 deg.	
K Maximum Dump Angle at Full Height	49.0 deg.		45.8 deg.	
Capacity, Heaped, with Bolt-On Cutting Edge	4.0 cu. yd. (3.1 m ³)	5.0 cu. yd. (3.8 m ³)	4.0 cu. yd. (3.1 m ³)	5.0 cu. yd. (3.8 m ³)
Capacity, Struck	3.5 cu. yd. (2.7 m ³)	4.36 cu. yd. (3.3 m ³)	3.5 cu. yd. (2.7 m ³)	4.36 cu. yd. (3.3 m ³)
Breakout Force	21,117 lb. (9579 kg)	18,262 lb. (8284 kg)	19,371 lb. (8787 kg)	16,721 lb. (7585 kg)
Tipping Load, Straight	24,770 lb. (11 236 kg)	23,830 lb. (10 809 kg)	21,171 lb. (9603 kg)	20,305 lb. (9210 kg)
Tipping Load, 40-deg. Full Turn	21,531 lb. (9766 kg)	20,658 lb. (9370 kg)	18,338 lb. (8318 kg)	17,531 lb. (7952 kg)
Bucket Weight	3,200 lb. (1451 kg)	3,600 lb. (1633 kg)	3,200 lb. (1451 kg)	3,600 lb. (1633 kg)
Bucket Width	8 ft. 10 in. (2.69 m)	8 ft. 10 in. (2.69 m)	8 ft. 10 in. (2.69 m)	8 ft. 10 in. (2.69 m)
Reach, 45-deg. Dump, 7-ft. (2.13 m) Clearance	4 ft. 6 in. (1.38 m)	4 ft. 9 in. (1.44 m)	5 ft. 6 in. (1.68 m)	5 ft. 9 in. (1.74 m)
Loader Clearance Circle, Bucket Carry Position	38 ft. 10 in. (11.84 m)	39 ft. 3 in. (11.96 m)	39 ft. 10 in. (12.15 m)	40 ft. 3 in. (12.28 m)

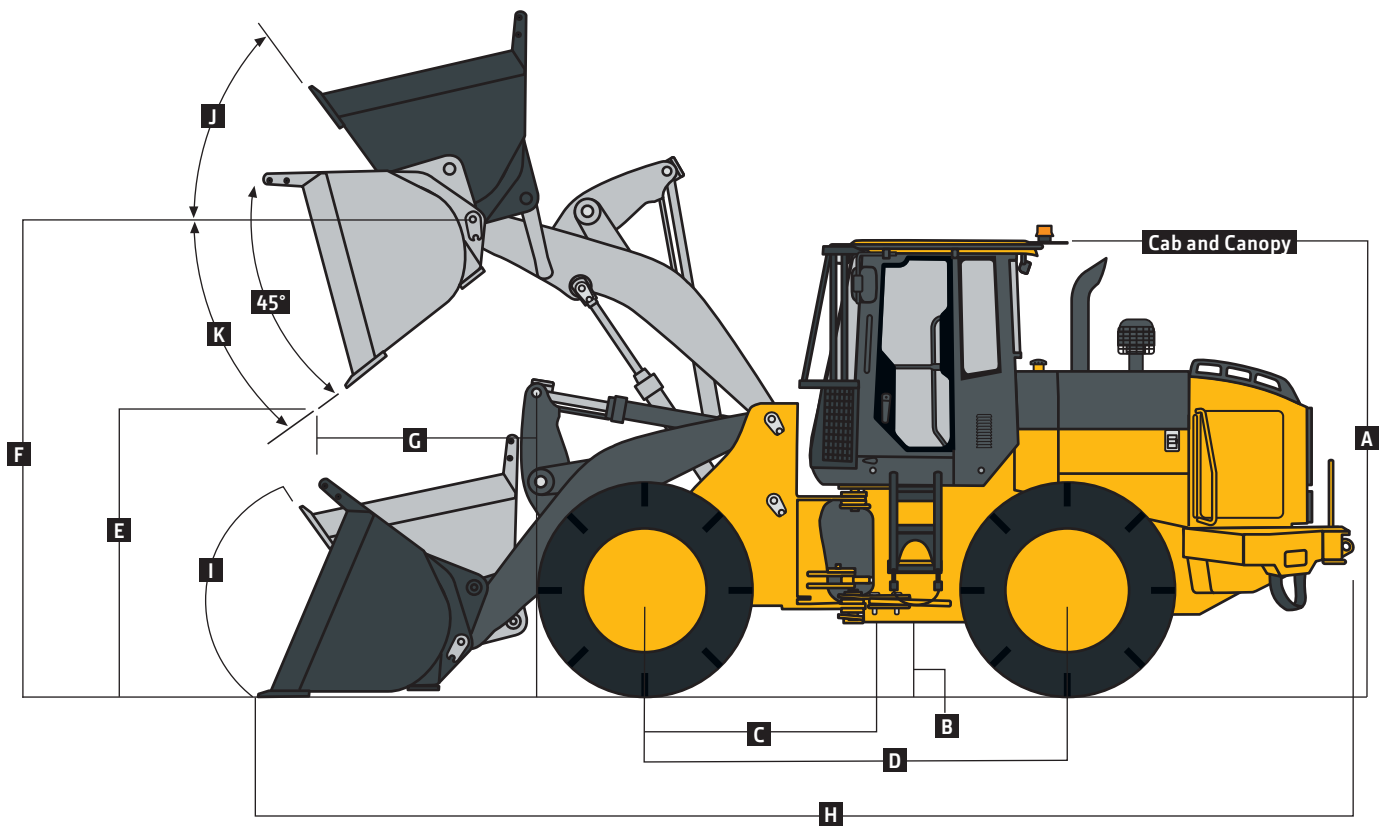

624K WH / 644K WH

Engine	624K WH		644K WH	
Manufacturer and Model	John Deere PowerTech™ Plus 6068H		John Deere PowerTech Plus 6068H	
Non-Road Emission Standards	Certified to EPA Tier 3 emissions		Certified to EPA Tier 3 emissions	
Cylinders	6		6	
Valves per Cylinder	4		4	
Displacement	415 cu. in. (6.8 L)		415 cu. in. (6.8 L)	
Net Peak Power	198 hp (147 kW) at 1,800 rpm		232 hp (173 kW) at 1,700 rpm	
Net Peak Torque	617 lb.-ft. (836 Nm) at 1,600 rpm		749 lb.-ft. (1016 Nm) at 1,400 rpm	
Net Torque Rise	55%		55%	
Fuel System (electronically controlled)	High-pressure common rail		High-pressure common rail	
Lubrication	Full-flow spin-on filter and integral cooler		Full-flow spin-on filter and integral cooler	
Aspiration	Turbocharged, charge air cooled		Turbocharged, charge air cooled	
Air Cleaner	Under-hood dual-element dry type; restriction indicator in cab monitor for service			
Cooling				
Fan Drive	Hydraulically driven, proportionally controlled, fan aft of coolers			
Fan Type	Blower type		Blower type	
Engine Coolant Rating	-34 deg. F (-37 deg. C)		-34 deg. F (-37 deg. C)	
Engine Radiator	8.0 fins per in. (water to air)		8.0 fins per in. (water to air)	
Hydraulic Cooler	6.0 fins per in. (oil to air)		6.3 fins per in. (oil to air)	
Charge Air Cooler	6.0 fins per in. (air to air)		6.3 fins per in. (air to air)	
Transmission Oil Cooler	6.0 fins per in. (oil to air)		6.3 fins per in. (oil to air)	
Transmission				
Type	Countershaft-type PowerShift™		Countershaft-type PowerShift	
Torque Converter	Single stage, single phase		Single stage, single phase	
Operator Interface	Steering-column- or joystick-mounted F-N-R and gear-select lever; quick-shift button on hydraulic lever			
Shift Control	Electronically modulated, adaptive, load and speed dependent			
Shift Modes	Manual/auto (1st-D or 2nd-D); quick-shift button with 2 selectable modes: kick-down or kick-up/down; and 3 adjustable clutch cutoff settings			
Maximum Gear	Programmable via monitor		Programmable via monitor	
	<i>With 20.5-25 Tires</i>		<i>With 23.5-25 Tires</i>	
Travel Speeds	<i>Forward Maximum</i>	<i>Reverse Maximum</i>	<i>Forward Maximum</i>	<i>Reverse Maximum</i>
Gear 1	4.7 mph (7.6 km/h)	4.7 mph (7.6 km/h)	4.7 mph (7.6 km/h)	4.9 mph (7.9 km/h)
Gear 2	7.8 mph (12.5 km/h)	8.1 mph (13.0 km/h)	7.8 mph (12.6 km/h)	8.0 mph (12.9 km/h)
Gear 3	15.5 mph (25.0 km/h)	16.0 mph (25.7 km/h)	15.3 mph (24.7 km/h)	15.5 mph (24.9 km/h)
Gear 4	24.5 mph (39.5 km/h)	—	22.7 mph (36.6 km/h)	—
Axles/Brakes				
Final Drives	Heavy-duty inboard-mounted planetary		Heavy-duty inboard-mounted planetary	
Differentials	Hydraulic locking front with conventional rear – standard; dual locking front and rear – optional			
Rear Axle Oscillation (stop to stop)	24 deg.		26 deg.	
Brakes (conform to ISO 3450)				
Service Brakes	Hydraulically actuated, inboard sun-shaft mounted, oil cooled, self-adjusting, single disc			
Parking Brake	Automatic spring applied, hydraulically released, driveline mounted, oil cooled, multi disc			



Tires/Wheels	624K WH		644K WH	
	<i>With 20.5 x 25 Solid Rubber Tires</i>		<i>With 23.5 x 25 Solid Rubber Tires</i>	
Tread Width	80.7 in. (2050 mm)		85.4 in. (2169 mm)	
Width Over Tires	101.3 in. (2573 mm)		113.2 in. (2875 mm)	
Hydraulic System/Steering				
Pump (loader and steering)	Variable-displacement, axial-piston pump; closed-center, pressure-compensating system			
Maximum Rated Flow at 1,000 psi (6895 kPa) and 2,350 rpm	59 gpm (223 L/m)		82 gpm (310 L/m)	
System Relief Pressure, Loader and Steering	3,675 psi (24 821 kPa)		3,650 psi (25 166 kPa)	
Loader Controls	2-function valve; joystick or fingertip control; hydraulic-function enable/disable; optional 3rd- and 4th-function valve with auxiliary lever			
Steering (conforms to ISO 5010)				
Type	Power, fully hydraulic		Power, fully hydraulic	
Articulation Angle	80-deg. arc (40 deg. each direction)		80-deg. arc (40 deg. each direction)	
Hydraulic Cycle Times	<i>Standard Z-Bar</i>	<i>High-Lift Z-Bar</i>	<i>Standard Z-Bar</i>	<i>High-Lift Z-Bar</i>
Raise	5.9 sec.	5.9 sec.	5.5 sec.	5.5 sec.
Dump	1.3 sec.	1.3 sec.	1.4 sec.	1.4 sec.
Lower (float down)	2.7 sec.	2.7 sec.	3.0 sec.	3.0 sec.
Total	9.9 sec.	9.9 sec.	9.9 sec.	9.9 sec.
Turning Radius				
Measured to Centerline of Outside Tire	17 ft. 4 in. (5.27 m)		18 ft. 3 in. (5.57 m)	
Electrical System	624K WH / 644K WH			
Electrical System	24 volt with 80-amp alternator (100-amp alternator optional)			
Batteries (2 – 12 volt)	950 CCA (each)			
Serviceability	624K WH		644K WH	
Refill Capacities				
Fuel Tank	93 gal. (352 L)		93 gal. (352 L)	
Cooling System	29 qt. (27 L)		31 qt. (29.5 L)	
Engine Oil with Vertical Spin-On Filter	20 qt. (19 L)		26 qt. (24.5 L)	
Transmission Fluid with Vertical Spin-On Filter	22 qt. (21 L)		24 qt. (23 L)	
Axle Oil				
Front	23 qt. (22 L)		23 qt. (22 L)	
Rear	18 qt. (17 L)		23 qt. (22 L)	
Hydraulic Reservoir and Filters	29 gal. (110 L)		29 gal. (110 L)	
Park Brake Oil (wet disc)	10 oz. (0.3 L)		20 oz. (0.6 L)	
Operating Weights				
All configurations include waste-handler protection, cab, full fuel tank, and 175-lb. (79 kg) operator				
	<i>With 20.5 x 25 Solid Rubber Tires</i>		<i>With 23.5 x 25 Solid Rubber Tires</i>	
	<i>Standard Z-Bar</i>	<i>High-Lift Z-Bar</i>	<i>Standard Z-Bar</i>	<i>High-Lift Z-Bar</i>
4.0-cu.-yd. (3.1 m ³) Standard-Lip Bucket	38,404 lb. (17 420 kg)	38,699 lb. (17 554 kg)	—	—
5.0-cu.-yd. (3.8 m ³) Standard-Lip Bucket	38,754 lb. (17 578 kg)	39,049 lb. (17 712 kg)	46,842 lb. (21 247 kg)	47,296 lb. (21 453 kg)
6.0-cu.-yd. (4.6 m ³) Standard-Lip Bucket	39,254 lb. (17 805 kg)	39,549 lb. (17 939 kg)	47,542 lb. (21 565 kg)	47,997 lb. (21 771 kg)
7.0-cu.-yd. (5.35 m ³) Standard-Lip Bucket	—	—	48,142 lb. (21 837 kg)	48,596 lb. (22 043 kg)

Machine Dimensions

624K WH

	<i>Standard Z-Bar</i>			<i>High-Lift Z-Bar</i>		
Linkage with Pin-On Bucket	<i>Standard Z-Bar</i>			<i>High-Lift Z-Bar</i>		
A Height to Top of Cab and Canopy	11 ft. 1 in. (3.39 m)			11 ft. 1 in. (3.39 m)		
B Ground Clearance	17.6 in. (0.45 m)			17.6 in. (0.45 m)		
C Length from Centerline to Front Axle	5 ft. 0 in. (1.52 m)			5 ft. 0 in. (1.52 m)		
D Wheelbase	10 ft. 1 in. (3.09 m)			10 ft. 1 in. (3.09 m)		
E Dump Clearance						
With 4.0-cu.-yd. (3.1 m ³) Bucket	8 ft. 11 in. (2.71 m)			10 ft. 8 in. (3.25 m)		
With 5.0-cu.-yd. (3.8 m ³) Bucket	9 ft. 1 in. (2.77 m)			10 ft. 3 in. (3.13 m)		
With 6.0-cu.-yd. (4.6 m ³) Bucket	8 ft. 7 in. (2.61 m)			9 ft. 9 in. (2.98 m)		
F Height to Hinge Pin, Fully Raised	13 ft. 2 in. (4.01 m)			14 ft. 4 in. (4.38 m)		
G Dump Reach						
With 4.0-cu.-yd. (3.1 m ³) Bucket	3 ft. 0 in. (0.91 m)			3 ft. 2 in. (0.97 m)		
With 5.0-cu.-yd. (3.8 m ³) Bucket	3 ft. 3 in. (1.00 m)			3 ft. 7 in. (1.09 m)		
With 6.0-cu.-yd. (4.6 m ³) Bucket	3 ft. 10 in. (1.17 m)			4 ft. 1 in. (1.25 m)		
H Overall Length						
With 4.0-cu.-yd. (3.1 m ³) Bucket	25 ft. 8 in. (7.82 m)			26 ft. 6 in. (8.07 m)		
With 5.0-cu.-yd. (3.8 m ³) Bucket	25 ft. 8 in. (7.82 m)			27 ft. 0 in. (8.24 m)		
With 6.0-cu.-yd. (4.6 m ³) Bucket	26 ft. 5 in. (8.05 m)			27 ft. 9 in. (8.47 m)		
I Maximum Rollback at Ground Level	34.2 deg.			34.7 deg.		
J Maximum Rollback at Full Height	51.1 deg.			47.4 deg.		
K Maximum Dump Angle at Full Height	49.0 deg.			45.5 deg.		
Capacity, Heaped, with Bolt-On Cutting Edge	4.0 cu. yd. (3.1 m ³)	5.0 cu. yd. (3.8 m ³)	6.0 cu. yd. (4.6 m ³)	4.0 cu. yd. (3.1 m ³)	5.0 cu. yd. (3.8 m ³)	6.0 cu. yd. (4.6 m ³)
Capacity, Struck	3.5 cu. yd. (2.7 m ³)	4.3 cu. yd. (3.3 m ³)	4.6 cu. yd. (3.5 m ³)	3.5 cu. yd. (2.7 m ³)	3.8 cu. yd. (2.9 m ³)	4.6 cu. yd. (3.5 m ³)
Breakout Force	29,774 lb. (13 505 kg)	25,567 lb. (11 597 kg)	21,300 lb. (9662 kg)	26,991 lb. (12 243 kg)	23,137 lb. (10 495 kg)	19,223 lb. (8719 kg)
Tipping Load, Straight	27,763 lb. (12 593 kg)	26,898 lb. (12 201 kg)	25,717 lb. (11 665 kg)	22,869 lb. (10 373 kg)	22, 103 lb. (10 026 kg)	21,064 lb. (9554 kg)
Tipping Load, 40-deg. Full Turn	24,156 lb. (10 957 kg)	23,354 lb. (10 593 kg)	22,255 lb. (10 095 kg)	19,809 lb. (8985 kg)	19,095 lb. (8661 kg)	18,122 lb. (8220 kg)
Bucket Weight	3,550 lb. (1610 kg)	3,900 lb. (1769 kg)	4,400 lb. (1996 kg)	3,550 lb. (1610 kg)	3,550 lb. (1610 kg)	4,400 lb. (1996 kg)
Bucket Width	9 ft. 6 in. (2.90 m)	9 ft. 6 in. (2.90 m)	9 ft. 6 in. (2.90 m)	9 ft. 6 in. (2.90 m)	9 ft. 6 in. (2.90 m)	9 ft. 6 in. (2.90 m)
Reach, 45-deg. Dump, 7-ft. (2.13 m) Clearance	4 ft. 9 in. (1.44 m)	4 ft. 11 in. (1.49 m)	5 ft. 2 in. (1.56 m)	5 ft. 11 in. (1.80 m)	5 ft. 11 in. (1.80 m)	6 ft. 5 in. (1.95 m)
Loader Clearance Circle, Bucket Carry Position	40 ft. 10 in. (12.45 m)	41 ft. 2 in. (12.55 m)	41 ft. 8 in. (12.69 m)	42 ft. 0 in. (12.81 m)	42 ft. 5 in. (12.92 m)	42 ft. 11 in. (13.08 m)

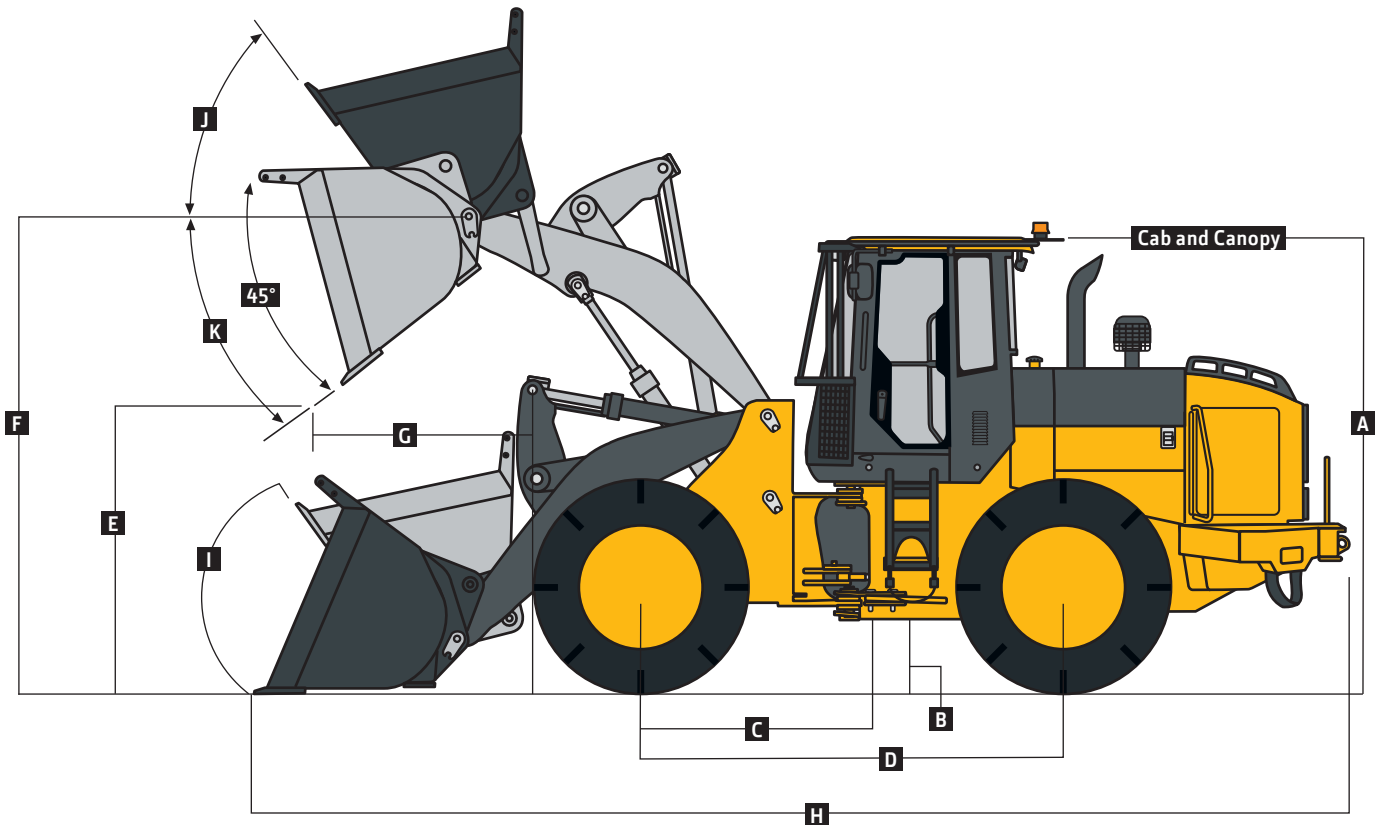

Machine Dimensions		644K WH					
Linkage with Pin-On Bucket		Standard Z-Bar			High-Lift Z-Bar		
A	Height to Top of Cab and Canopy	11 ft. 5 in. (3.47 m)			11 ft. 5 in. (3.47 m)		
B	Ground Clearance	20 in. (516 mm)			20 in. (516 mm)		
C	Length from Centerline to Front Axle	5 ft. 3 in. (1.60 m)			5 ft. 3 in. (1.60 m)		
D	Wheelbase	10 ft. 8 in. (3.26 m)			10 ft. 8 in. (3.26 m)		
E	Dump Clearance						
	With 5.0-cu.-yd. (3.8 m ³) Bucket	9 ft. 8 in. (2.96 m)			11 ft. 4 in. (3.45 m)		
	With 6.0-cu.-yd. (4.6 m ³) Bucket	9 ft. 2 in. (2.79 m)			10 ft. 10 in. (3.30 m)		
	With 7.0-cu.-yd. (5.4 m ³) Bucket	8 ft. 10 in. (2.69 m)			10 ft. 6 in. (3.21 m)		
F	Height to Hinge Pin, Fully Raised	13 ft. 10 in. (4.21 m)			15 ft. 2 in. (4.63 m)		
G	Dump Reach						
	With 5.0-cu.-yd. (3.8 m ³) Bucket	3 ft. 1 in. (0.93 mm)			3 ft. 9 in. (1.15 m)		
	With 6.0-cu.-yd. (4.6 m ³) Bucket	3 ft. 7 in. (1.08 m)			4 ft. 4 in. (1.33 m)		
	With 7.0-cu.-yd. (5.4 m ³) Bucket	3 ft. 11 in. (1.19 m)			4 ft. 9 in. (1.44 m)		
H	Overall Length						
	With 5.0-cu.-yd. (3.8 m ³) Bucket	26 ft. 3 in. (7.99 m)			27 ft. 10 in. (8.49 m)		
	With 6.0-cu.-yd. (4.6 m ³) Bucket	27 ft. 0 in. (8.22 m)			28 ft. 7 in. (8.71 m)		
	With 7.0-cu.-yd. (5.4 m ³) Bucket	27 ft. 6 in. (8.37 m)			29 ft. 1 in. (8.86 m)		
I	Maximum Rollback at Ground Level	37.0 deg.			39.0 deg.		
J	Maximum Rollback at Full Height	55.0 deg.			47.0 deg.		
K	Maximum Dump Angle at Full Height	45.0 deg.			40.0 deg.		
	Capacity, Heaped, with Bolt-On Cutting Edge	5.0 cu. yd. (3.8 m ³)	6.0 cu. yd. (4.6 m ³)	7.0 cu. yd. (5.4 m ³)	5.0 cu. yd. (3.8 m ³)	6.0 cu. yd. (4.6 m ³)	7.0 cu. yd. (5.4 m ³)
	Capacity, Struck	4.3 cu. yd. (3.3 m ³)	5.5 cu. yd. (4.2 m ³)	6.2 cu. yd. (4.8 m ³)	4.3 cu. yd. (3.3 m ³)	5.5 cu. yd. (4.2 m ³)	6.2 cu. yd. (4.8 m ³)
	Breakout Force	34,471 lb. (15 636 kg)	28,848 lb. (13 085 kg)	26,043 lb. (11 813 kg)	30,674 lb. (13 913 kg)	25,604 lb. (11 614 kg)	23,075 lb. (10 467 kg)
	Tipping Load, Straight	33,711 lb. (15 291 kg)	32,213 lb. (14 612 kg)	30,624 lb. (13 891 kg)	27,060 lb. (12 274 kg)	25,730 lb. (11 671 kg)	24,387 lb. (11 062 kg)
	Tipping Load, 40-deg. Full Turn	29,328 lb. (13 303 kg)	27,915 lb. (12 662 kg)	26,450 lb. (11 997 kg)	23,418 lb. (10 622 kg)	22,157 lb. (10 050 kg)	20,909 lb. (9484 kg)
	Bucket Weight	3,800 lb. (1724 kg)	4,000 lb. (1814 kg)	4,800 lb. (2177 kg)	3,800 lb. (1724 kg)	4,000 lb. (1814 kg)	4,800 lb. (2177 kg)
	Bucket Width	9 ft. 6 in. (2.90 m)	9 ft. 6 in. (2.90 m)	9 ft. 6 in. (2.90 m)	9 ft. 6 in. (2.90 m)	9 ft. 6 in. (2.90 m)	9 ft. 6 in. (2.90 m)
	Reach, 45-deg. Dump, 7-ft. (2.13 m) Clearance	6 ft. 5 in. (1.96 m)	5 ft. 3 in. (1.60 m)	5 ft. 4 in. (1.64 m)	6 ft. 5 in. (1.96 m)	6 ft. 9 in. (2.05 m)	6 ft. 11 in. (2.10 m)
	Loader Clearance Circle, Bucket Carry Position	42 ft. 9 in. (13.02 m)	43 ft. 2 in. (13.16 m)	43 ft. 6 in. (13.26 m)	44 ft. 1 in. (13.45 m)	44 ft. 7 in. (13.60 m)	44 ft. 11 in. (13.70 m)

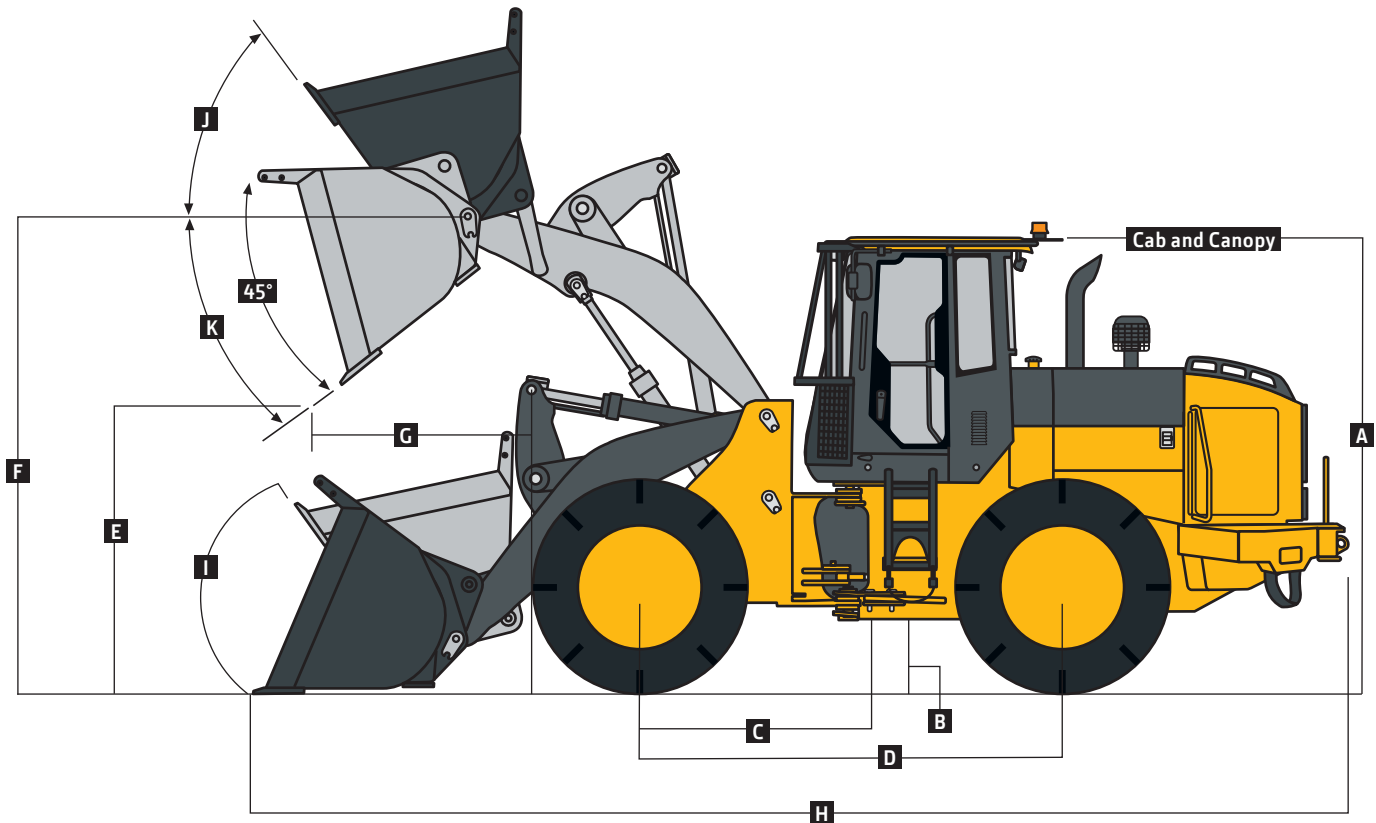

724K WH / 744K WH

Engine	724K WH	744K WH
Manufacturer and Model	John Deere PowerTech™ Plus 6090H	John Deere PowerTech Plus 6090H
Non-Road Emission Standards	Certified to EPA Tier 3 emissions	Certified to EPA Tier 3 emissions
Cylinders	6	6
Valves per Cylinder	4	4
Displacement	548 cu. in. (9.0 L)	548 cu. in. (9.0 L)
Net Peak Power	264 hp (197 kW) at 1,800 rpm	304 hp (227 kW) at 1,500 rpm
Net Peak Torque	852 lb.-ft. (1159 Nm) at 1,300 rpm	1,074 lb.-ft. (1456 Nm) at 1,400 rpm
Net Torque Rise	36%	47%
Fuel System (electronically controlled)	High-pressure common rail	High-pressure common rail
Lubrication	Full-flow spin-on filter and integral cooler	Full-flow spin-on filter and integral cooler
Aspiration	Turbocharged, charge air cooled	Turbocharged, charge air cooled
Air Cleaner	Under-hood dual-element dry type; restriction indicator in cab monitor for service	
Cooling		
Fan Drive	Hydraulically driven, proportionally controlled, fan aft of coolers	
Fan Type	Blower type	Blower type
Engine Coolant Rating	-34 deg. F (-37 deg. C)	-34 deg. F (-37 deg. C)
Engine Radiator	8.0 fins per in. (water to air)	10.0 fins per in. (water to air)
Hydraulic Cooler	6.0 fins per in. (oil to air)	10.5 fins per in. (oil to air)
Charge Air Cooler	10.5 fins per in. (air to air)	10.5 fins per in. (air to air)
Transmission Oil Cooler	10.5 fins per in. (oil to air)	10.5 fins per in. (oil to air)
Transmission		
Type	Countershaft-type PowerShift™	Countershaft-type PowerShift
Torque Converter	Single stage, single phase	Single stage, dual phase with freewheeling stator torque
Operator Interface	Steering-column- or joystick-mounted F-N-R and gear-select lever; quick-shift button on hydraulic lever	
Shift Control	Electronically modulated, adaptive, load and speed dependent	
Shift Modes	Manual/auto (1st-D or 2nd-D); quick-shift button with 2 selectable modes: kick-down or kick-up/down; and 3 adjustable clutch cutoff settings	
Maximum Gear	Programmable via monitor <i>With 23.5 R 25 Radial Tires</i>	Programmable via monitor <i>With 26.5 R 25 1 Star Radial Tires</i>
Travel Speeds	<i>Forward Maximum</i>	<i>Reverse Maximum</i>
Gear 1	4.5 mph (7.2 km/h)	4.7 mph (7.6 km/h)
Gear 2	7.4 mph (11.9 km/h)	7.8 mph (12.5 km/h)
Gear 3	14.4 mph (23.1 km/h)	15.1 mph (24.2 km/h)
Gear 4	22.1 mph (35.6 km/h)	—
Axles/Brakes	724K WH / 744K WH	
Final Drives	Heavy-duty inboard-mounted planetary	
Differentials	Hydraulic locking front with conventional rear – standard; dual locking front and rear – optional	
Rear Axle Oscillation (stop to stop)	26 deg.	
Brakes (conform to ISO 3450)		
Service Brakes	Hydraulically actuated, inboard sun-shaft mounted, oil cooled, self-adjusting, single disc	
Parking Brake	Automatic spring applied, hydraulically released, driveline mounted, oil cooled, multi disc	



Tires/Wheels	724K WH		744K WH		
	With 23.5 x 25 Solid Rubber Tires		With 31.5 x 25 Solid Rubber Tires	With 26.5 x 25 Solid Rubber Tires	With 26.5 R 25 X-MINE L5 Michelin Radial Tires
Tread Width	85.4 in. (2169 mm)		95.0 in. (2400 mm)	89.5 in. (2273 mm)	86.6 in. (2200 mm)
Width Over Tires	113.2 in. (2875 mm)		126.0 in. (3200 mm)	116.0 in. (2946 mm)	116.2 in. (2951 mm)
Hydraulic System/Steering					
Pump (loader and steering)	Variable-displacement, axial-piston pump; closed-center, pressure-compensating system		2 variable-displacement, load-sensing, axial-piston pumps; closed-center, pressure-compensating system		
Maximum Rated Flow at 1,000 psi (6895 kPa) and 2,250 rpm	82 gpm (310 L/m)		136 gpm (515 L/m)		
System Relief Pressure, Loader and Steering	3,650 psi (25 166 kPa)		3,288 psi (22 670 kPa)		
Loader Controls					
	2-function valve; joystick or fingertip control; hydraulic-function enable/disable; optional 3rd- and 4th-function valve with auxiliary lever		2-function valve; single- or dual-lever controls; control lever lockout feature; optional 3rd- and 4th-function valve with auxiliary levers		
Steering (conforms to ISO 5010)					
Type	Power, fully hydraulic		Power, fully hydraulic		
Articulation Angle	80-deg. arc (40 deg. each direction)		80-deg. arc (40 deg. each direction)		
Hydraulic Cycle Times					
	<i>Standard Z-Bar</i>	<i>High-Lift Z-Bar</i>	<i>Standard Z-Bar</i>	<i>High-Lift Z-Bar</i>	
Raise	5.5 sec.	5.5 sec.	5.9 sec.	5.9 sec.	
Dump	1.2 sec.	1.4 sec.	1.4 sec.	1.4 sec.	
Lower (float down)	3.0 sec.	3.0 sec.	2.8 sec.	2.8 sec.	
Total	9.7 sec.	9.9 sec.	10.1 sec.	10.1 sec.	
Turning Radius					
Measured to Centerline of Outside Tire	18 ft. 6 in. (5.64 m)		20 ft. 7 in. (6.28 m)		
Electrical System					
Electrical System	724K WH / 744K WH				
Batteries (2 – 12 volt)	24 volt with 80-amp alternator (100-amp alternator optional)				
	1,400 CCA (each)				
Serviceability					
	724K WH		744K WH		
Refill Capacities					
Fuel Tank	93 gal. (352 L)		124 gal. (469 L)		
Cooling System	36 qt. (34 L)		47 qt. (45 L)		
Engine Oil with Vertical Spin-On Filter	30 qt. (28 L)		36 qt. (34 L)		
Transmission Fluid with Vertical Spin-On Filter	25 qt. (24 L)		29.5 qt. (27.9 L)		
Axle Oil (front and rear)	23 qt. (22 L)		49 qt. (46 L)		
Hydraulic Reservoir and Filters	29 gal. (110 L)		42 gal. (159 L)		
Park Brake Oil (wet disc)	20 oz. (0.6 L)		24 oz. (0.7 L)		
Operating Weights					
All configurations include waste-handler protection, cab, full fuel tank, and 175-lb. (79 kg) operator					
	With 23.5 x 25 Solid Rubber Tires		With 31.5 x 25 Solid Rubber Tires		
	<i>Standard Z-Bar</i>	<i>High-Lift Z-Bar</i>	<i>Standard Z-Bar</i>	<i>High-Lift Z-Bar</i>	
5.0-cu.-yd. (3.8 m ³) Standard-Lip Bucket	48,988 lb. (22 200 kg)	49,486 lb. (22 447 kg)	—	—	
6.0-cu.-yd. (4.6 m ³) Standard-Lip Bucket	49,688 lb. (22 538 kg)	50,186 lb. (22 764 kg)	64,315 lb. (29 173 kg)	65,530 lb. (29 724 kg)	
7.0-cu.-yd. (5.4 m ³) Standard-Lip Bucket	50,288 lb. (22 810 kg)	50,786 lb. (23 036 kg)	64,738 lb. (29 365 kg)	65,953 lb. (29 916 kg)	
8.0-cu.-yd. (6.1 m ³) Standard-Lip Bucket	—	—	65,049 lb. (29 506 kg)	66,263 lb. (30 057 kg)	

Machine Dimensions	724K WH					
Linkage with Pin-On Bucket	Standard Z-Bar			High-Lift Z-Bar		
A Height to Top of Cab and Canopy	11 ft. 5 in. (3.47 m)			11 ft. 5 in. (3.47 m)		
B Ground Clearance	20 in. (516 mm)			20 in. (516 mm)		
C Length from Centerline to Front Axle	5 ft. 3 in. (1.60 m)			5 ft. 3 in. (1.60 m)		
D Wheelbase	10 ft. 8 in. (3.26 m)			10 ft. 8 in. (3.26 m)		
E Dump Clearance						
With 5.0-cu.-yd. (3.8 m ³) Bucket	9 ft. 8 in. (2.96 m)			11 ft. 4 in. (3.45 m)		
With 6.0-cu.-yd. (4.6 m ³) Bucket	9 ft. 2 in. (2.79 m)			10 ft. 10 in. (3.30 m)		
With 7.0-cu.-yd. (5.4 m ³) Bucket	8 ft. 10 in. (2.69 m)			10 ft. 6 in. (3.21 m)		
F Height to Hinge Pin, Fully Raised	13 ft. 10 in. (4.21 m)			15 ft. 2 in. (4.63 m)		
G Dump Reach						
With 5.0-cu.-yd. (3.8 m ³) Bucket	3 ft. 1 in. (0.93 m)			3 ft. 9 in. (1.15 m)		
With 6.0-cu.-yd. (4.6 m ³) Bucket	3 ft. 7 in. (1.08 m)			4 ft. 4 in. (1.33 m)		
With 7.0-cu.-yd. (5.4 m ³) Bucket	3 ft. 11 in. (1.19 m)			4 ft. 9 in. (1.44 m)		
H Overall Length						
With 5.0-cu.-yd. (3.8 m ³) Bucket	26 ft. 3 in. (7.99 m)			27 ft. 10 in. (8.49 m)		
With 6.0-cu.-yd. (4.6 m ³) Bucket	27 ft. 0 in. (8.22 m)			28 ft. 7 in. (8.71 m)		
With 7.0-cu.-yd. (5.4 m ³) Bucket	27 ft. 6 in. (8.37 m)			29 ft. 1 in. (8.86 m)		
I Maximum Rollback at Ground Level	37.0 deg.			39.0 deg.		
J Maximum Rollback at Full Height	55.0 deg.			47.0 deg.		
K Maximum Dump Angle at Full Height	45.0 deg.			40.0 deg.		
Capacity, Heaped, with Bolt-On Cutting Edge	5.0 cu. yd. (3.8 m ³)	6.0 cu. yd. (4.6 m ³)	7.0 cu. yd. (5.4 m ³)	5.0 cu. yd. (3.8 m ³)	6.0 cu. yd. (4.6 m ³)	7.0 cu. yd. (5.4 m ³)
Capacity, Struck	4.3 cu. yd. (3.3 m ³)	5.5 cu. yd. (4.2 m ³)	6.2 cu. yd. (4.8 m ³)	4.3 cu. yd. (3.3 m ³)	5.5 cu. yd. (4.2 m ³)	6.2 cu. yd. (4.8 m ³)
Breakout Force	34,471 lb. (15 636 kg)	28,848 lb. (13 085 kg)	26,043 lb. (11 813 kg)	30,674 lb. (13 913 kg)	25,604 lb. (11 614 kg)	23,075 lb. (10 467 kg)
Tipping Load, Straight	37,872 lb. (17 178 kg)	36,292 lb. (16 462 kg)	34,586 lb. (15 688 kg)	30,514 lb. (13 841 kg)	29,118 lb. (13 208 kg)	27,686 lb. (12 558 kg)
Tipping Load, 40-deg. Full Turn	32,875 lb. (14 912 kg)	31,393 lb. (14 240 kg)	29,827 lb. (13 530 kg)	26,362 lb. (11 958 kg)	25,045 lb. (11 360 kg)	23,720 lb. (10 759 kg)
Bucket Weight	3,800 lb. (1724 kg)	4,000 lb. (1814 kg)	4,800 lb. (2177 kg)	3,800 lb. (1724 kg)	4,000 lb. (1814 kg)	4,800 lb. (2177 kg)
Bucket Width	9 ft. 6 in. (2.90 mm)	9 ft. 6 in. (2.90 mm)	9 ft. 6 in. (2.90 m)	9 ft. 6 in. (2.90 m)	9 ft. 6 in. (2.90 mm)	9 ft. 6 in. (2.90 m)
Reach, 45-deg. Dump, 7-ft. (2.13 m) Clearance	5 ft. 0 in. (1.53 m)	5 ft. 3 in. (1.60 m)	5 ft. 5 in. (1.65 m)	6 ft. 5 in. (1.96 m)	6 ft. 9 in. (2.05 m)	6 ft. 11 in. (2.10 m)
Loader Clearance Circle, Bucket Carry Position	42 ft. 9 in. (13.02 m)	43 ft. 2 in. (13.16 m)	43 ft. 6 in. (13.26 m)	44 ft. 1 in. (13.45 m)	44 ft. 7 in. (13.60 m)	44 ft. 11 in. (13.70 m)

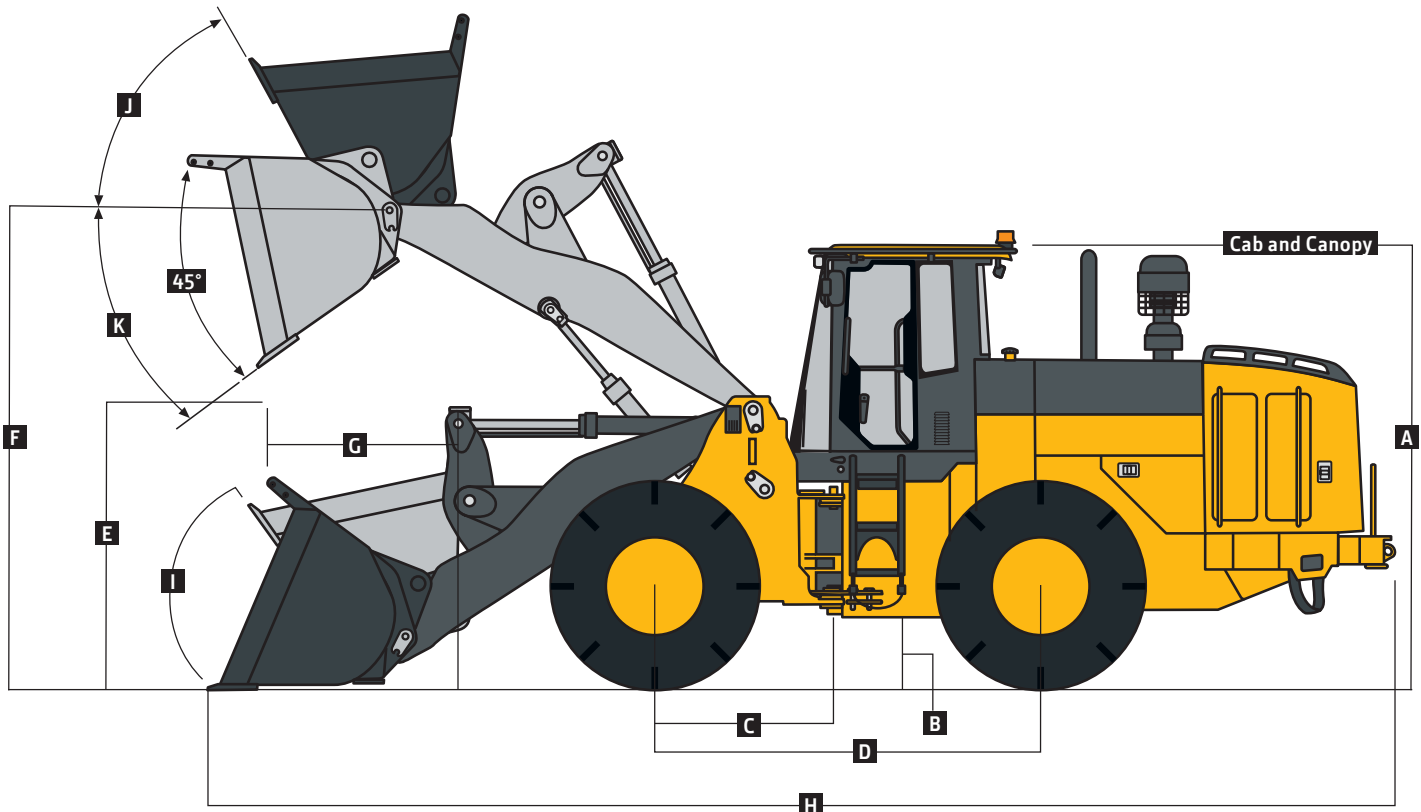

Machine Dimensions		744K WH					
Linkage with Pin-On Bucket		Standard Z-Bar			High-Lift Z-Bar		
A Height to Top of Cab and Canopy		11 ft. 8 in. (3.56 m)			11 ft. 8 in. (3.56 m)		
B Ground Clearance		21 in. (531 mm)			21 in. (531 mm)		
C Length from Centerline to Front Axle		5 ft. 7 in. (1.70 m)			5 ft. 3 in. (1.60 m)		
D Wheelbase		11 ft. 4 in. (3.46 m)			5 ft. 7 in. (1.70 m)		
E Dump Clearance							
With 6.0-cu.-yd. (4.7 m ³) Bucket		9 ft. 10 in. (2.99 m)			12 ft. 1 in. (3.69 m)		
With 7.0-cu.-yd. (5.3 m ³) Bucket		9 ft. 6 in. (2.89 m)			11 ft. 10 in. (3.61 m)		
With 8.0-cu.-yd. (6.1 m ³) Bucket		9 ft. 2 in. (2.79 m)			11 ft. 7 in. (3.52 m)		
F Height to Hinge Pin, Fully Raised		14 ft. 3 in. (4.33 m)			16 ft. 1 in. (4.90 m)		
G Dump Reach							
With 6.0-cu.-yd. (4.7 m ³) Bucket		3 ft. 10 in. (1.17 m)			4 ft. 11 in. (1.50 m)		
With 7.0-cu.-yd. (5.3 m ³) Bucket		4 ft. 2 in. (1.26 m)			5 ft. 3 in. (1.61 m)		
With 8.0-cu.-yd. (6.1 m ³) Bucket		4 ft. 6 in. (1.37 m)			5 ft. 8 in. (1.73 m)		
H Overall Length							
With 6.0-cu.-yd. (4.7 m ³) Bucket		29 ft. 6 in. (9.00 m)			31 ft. 8 in. (9.65 m)		
With 7.0-cu.-yd. (5.3 m ³) Bucket		29 ft. 11 in. (9.13 m)			32 ft. 1 in. (9.78 m)		
With 8.0-cu.-yd. (6.1 m ³) Bucket		30 ft. 6 in. (9.29 m)			32 ft. 7 in. (9.94 m)		
I Maximum Rollback at Ground Level		36.3 deg.			37.7 deg.		
J Maximum Rollback at Full Height		53.0 deg.			51.1 deg.		
K Maximum Dump Angle at Full Height		47.0 deg.			36.9 deg.		
Capacity, Heaped, with Bolt-On Cutting Edge		6.0 cu. yd. (4.6 m ³)	7.0 cu. yd. (5.4 m ³)	8.0 cu. yd. (6.1 m ³)	6.0 cu. yd. (4.6 m ³)	7.0 cu. yd. (5.3 m ³)	8.0 cu. yd. (6.1 m ³)
Capacity, Struck		5.3 cu. yd. (4.1 m ³)	6.2 cu. yd. (4.7 m ³)	7.1 cu. yd. (5.4 m ³)	5.3 cu. yd. (4.1 m ³)	6.2 cu. yd. (4.7 m ³)	7.1 cu. yd. (5.4 m ³)
Breakout Force		39,756 lb. (18 033 kg)	36,305 lb. (16 468 kg)	32,691 lb. (14 828 kg)	35,368 lb. (16 043 kg)	32,281 lb. (14 642 kg)	29,024 lb. (13 165 kg)
Tipping Load, Straight		47,772 lb. (21 669 kg)	46,788 lb. (21 223 kg)	45,837 lb. (20 792 kg)	38,442 lb. (17 437 kg)	36,956 lb. (16 763 kg)	36,281 lb. (16 427 kg)
Tipping Load, 40-deg. Full Turn		41,298 lb. (18 733 kg)	40,384 lb. (18 318 kg)	39,512 lb. (17 922 kg)	32,962 lb. (14 951 kg)	31,644 lb. (14 353 kg)	31,014 lb. (14 068 kg)
Bucket Weight		6,467 lb. (2933 kg)	6,889 lb. (3125 kg)	7,200 lb. (3266 kg)	6,467 lb. (2933 kg)	6,889 lb. (3125 kg)	7,200 lb. (3266 kg)
Bucket Width		10 ft. 8 in. (3.25 m)	10 ft. 8 in. (3.25 m)	10 ft. 8 in. (3.25 m)	10 ft. 8 in. (3.25 m)	10 ft. 8 in. (3.25 m)	10 ft. 8 in. (3.25 m)
Reach, 45-deg. Dump, 7-ft. (2.13 m) Clearance		5 ft. 10 in. (1.77 m)	5 ft. 11 in. (1.82 m)	6 ft. 1 in. (1.87 m)	7 ft. 8 in. (2.33 m)	7 ft. 8 in. (2.33 m)	8 ft. 0 in. (2.45 m)
Loader Clearance Circle, Bucket Carry Position		44 ft. 8 in. (13.61 m)	46 ft. 0 in. (14.02 m)	46 ft. 3 in. (14.10 m)	47 ft. 6 in. (14.48 m)	47 ft. 9 in. (14.55 m)	48 ft. 1 in. (14.66 m)

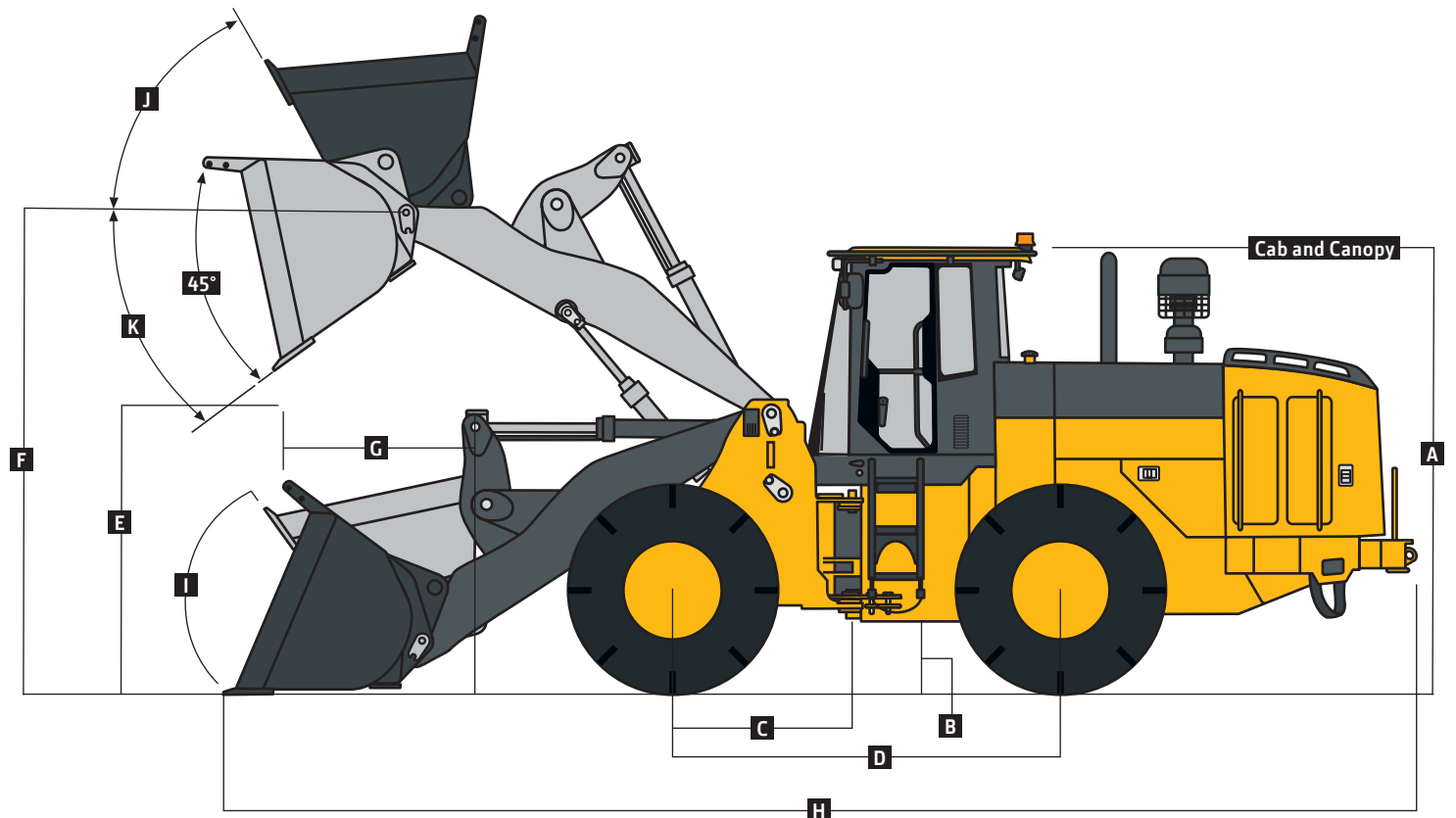

Additional equipment

Key: ● Standard ▲ Optional or special

See your John Deere dealer for further information.

524	544	624	644	724	744	Engine
●	●	●	●	●	●	Wet-sleeve cylinder liners
●	●	●	●	●	●	Automatic glow plugs for cold start
●	●	●	●	●	●	Programmable auto-idle and -shutdown
●	●	●	●	●	●	Selectable idle adjustment from 900–1,250 rpm
●	●	●	●	●	●	Automatic derating for exceeded system temperatures
●	●	●	●	●	●	Serpentine drive belt for automatic tensioner
				●	●	Electric fuel-priming pump
●	●	●	●	●	●	Dual-stage fuel filter and water separator
●	●	●	●	●	●	500-hour vertical spin-on oil filter
				●	●	Engine-compartment light
▲	▲	▲	▲	▲	▲	Chrome exhaust stack
▲	▲	▲	▲	▲	▲	Automatic ether starting aid (recommended for cold starts below 10 deg. F [–12 deg. C])
▲	▲	▲	▲	▲	▲	Engine-block heater (recommended for cold starts below –10 deg. F [–23 deg. C])
Powertrain						
●	●	●	●	●	●	Programmable maximum high gear
●	●	●	●	●	●	2,000-hour vertical spin-on transmission filter
				●	●	Transmission diagnostic ports
▲	▲	▲	▲	▲	●	Wheel-spin control
Quad-Cool™ Cooling System [new for 724K and 744K]						
●	●	●	●	●	●	Heavy-duty, trash-resistant radiator and high-ambient cooling package
●	●	●	●	●	●	Antifreeze, –34 deg. F (–37 deg. C)
●	●	●	●	●	●	Cool-on-demand swing-out fan
▲	▲	▲	▲	▲	▲	Automatic reversing fan drive
▲	▲	▲	▲	▲	▲	Axle coolers
▲	▲	▲	▲	▲	▲	Harsh environmental coolers
Hydraulics						
●	●	●	●	●	●	Automatic return to dig
●	●	●	●	●	●	In-cab adjustable automatic boom-height kickout/return to carry
●	●	●	●	●	●	Reservoir with sight gauge and fill strainer
●	●	●	●	●	●	Hydraulic diagnostic ports
●	●	●	●	●	●	4,000-hour in-tank filter
●	●	●	●	●	●	2-function hydraulic control
▲	▲	▲	▲	▲	▲	3-function hydraulic control
▲	▲	▲	▲	▲	▲	4-function hydraulic control
Steering Systems						
●	●	●	●	●	●	Conventional steering wheel with spinner knob
▲	▲	▲	▲	▲	▲	Joystick steering (including conventional steering column) with gear-shift, F-N-R, and horn
▲	▲	▲	▲	▲	▲	Secondary steering
Electrical						
●	●	●	●	●	●	Solid-state electrical power-distribution system
●	●	●	●	●	●	Battery-terminal safety covers
●	●	●	●	●	●	By-pass start safety cover at starter

524	544	624	644	724	744	Electrical (continued)
●	●	●	●	●	●	Lights: Halogen driving lights with guards (2) / Front (4) and rear (2) cab work lights (and rear grille (2) work lights for the 744K) / Turn signals and flashers / LED stop- and taillights
●	●	●	●	●	●	Reverse warning alarm
●	●	●	●	●	●	Multifunction/multi-language LCD color monitor
●	●	●	●	●	●	Indicator lights: Standard and selected options / Amber caution and red stop
●	●	●	●	●	●	Built-in diagnostics: Diagnostic-code details / Sensor values / Calibrations / Individual circuit tester
▲	▲	▲	▲	▲	▲	Electrical corrosion-prevention package
▲	▲	▲	▲	▲	▲	AM/FM/WB radio
▲	▲	▲	▲	▲	▲	AM/FM/WB radio with CD player
Operator's Station						
●	●	●	●	●	●	Key-less start with multiple security modes
●	●	●	●	●	●	Hydraulic controls integrated to seat
●	●	●	●	●	●	Cup holders (2)
●	●	●	●	●	●	Lunch-box/cooler holder
▲	▲	▲	▲	▲	▲	12-volt power port
●	●	●	●	●	●	Rubber floor mat
●	●	●	●	●	●	Tilt steering column
●	●	●	●	●	●	Outside and inside rearview mirrors
●	●	●	●	●	●	Slip-resistant steps and ergonomic handholds
▲	▲	▲	▲	▲	▲	Quiet cab with heater
▲	▲	▲	▲	●	●	Quiet cab with air conditioning/heater
●	●	●	●	●	●	Sun visor
●	●	●	●	●	●	Front and rear intermittent windshield wiper and washers
▲	▲	▲	▲	▲	▲	Premium seat with high-wide back and headrest extension, heated, leather/fabric cover, and adjustable air suspension
▲	▲	▲	▲	●	●	Seat with backrest extension, deep foam, fabric cover, and adjustable air suspension
▲	▲	▲	▲	▲	▲	Powered cab air pre-cleaner
▲	▲	▲	▲	▲	▲	Large heated outside mirrors
▲	▲	▲	▲	▲	▲	Rear camera and radar object-detection system
▲	▲	▲	▲	▲	▲	Embedded payload scale
▲	▲	▲	▲	▲	▲	Fire extinguisher
Waste-Handler Package						
●	●	●	●	●	●	Waste-handler guards: Articulation / Axle seal / Boom cylinder and hydraulic lines / Bucket-cylinder hydraulic lines, zerk, and sensor / Driveshaft / Extreme-duty front loader frame cover with handles / Extreme-duty transmission side / Lower boom and bucket grease-fitting / Rear loader frame cover / Drive, turn, and work light

524	544	624	644	724	744	Waste-Handler Package (continued)
●	●	●	●	●	●	Cab-floor-mounted lockable master electrical disconnect switch
●	●	●	●	●	●	Extreme-duty cab-entry steps
▲	▲	▲	▲	▲	▲	Extreme-duty hydraulic bottom guards (fuel tank, loader frame, and engine frame)
▲	▲	▲	▲	▲	▲	Bottom guards, bolt-on, front frame and transmission
●	●	●	●	●	●	Full-frontal cab window guard (high-visibility version not designed to SAE J1084)
●	●	●	●	●	●	Rear-access platforms with step, handhold, and tie-downs
●	●	●	●	●	●	Cab-roof-mounted strobe light
Loader Linkage						
●	●	●	●	●	●	Z-bar loader linkage
▲	▲	▲	▲	▲	▲	High-lift Z-bar loader linkage
Buckets and Attachments						
▲	▲	▲	▲	▲	▲	Full line of Deere pin-on buckets
▲	▲	▲	▲	▲	▲	Worksite Pro™ hydraulic coupler (accepts JRB-pattern attachments)
▲	▲	▲	▲	▲	▲	Hi-vis hydraulic coupler (accepts Euro-pattern attachments [Volvo])
▲	▲	▲	▲	▲	▲	Full line of Deere hook-on buckets and forks
▲	▲	▲	▲	▲	▲	Bolt-on fork frame guard
Overall Vehicle						
▲	▲	●	●	●	●	JDLink™ Ultimate wireless communication system (standard on 624K cabs / optional on 624K canopies)
●	●	●	●	●	●	NeverGrease™ rear-axle oscillation
●	●	●	●	●	●	NeverGrease steering-cylinder joints
●	●	●	●	●	●	Front and rear tie-downs
●	●	●	●	●	●	Fenders, front
▲	▲	▲	▲	▲	▲	Fenders, full-coverage, front or front and rear
●	●	●	●	●	●	Rear hitch with locking pin
▲	▲	▲	▲	▲	▲	Rear cast bumper/counterweight with rear hitch and locking pin
●	●	●	●	●	●	Articulation locking bar
●	●	●	●	●	●	Loader boom service locking bar
●	●	●	●	●	●	40-deg. steering articulation to each side
●	●	●	●	●	●	Vandal protection with lockable engine enclosures, right counterweight storage, battery box, and filler access for radiator/fuel/hydraulic/transmission
●	●	●	●	●	●	Ground-level fueling
▲	▲	▲	●	●	●	Environmental drains for engine, transmission, hydraulic oils, and engine coolant
▲	▲	▲	●	●	●	Fluid-sampling ports for engine, transmission, hydraulic and axle oils, and engine coolant
▲	▲	▲	▲	▲	▲	Level 1 or Level 2 sound package
			▲	▲	▲	Quick fluid service (engine, transmission, hydraulic oils, and engine coolant)
▲	▲	▲	▲	▲	▲	Close-mounted steps
▲	▲	▲	▲	▲	●	Lift eyes
▲	▲	▲	▲	▲	▲	License-plate bracket and light

Net engine power is with standard equipment including air cleaner, exhaust system, alternator, and cooling fan at test conditions per ISO 9249. No derating is required up to 5,000-ft. (1525 m) altitude for the 524K, 544K, and 624K, and up to 10,000-ft. (3050 m) altitude for the 644K, 724K, and 744K. Specifications and design subject to change without notice. Specifications are in accordance with ISO standards. Except where otherwise noted, these specifications are based on units with applicable linkage, waste-handler protection package, ROPS cab, full fuel tank, and 175-lb. (79 kg) operator; 524K, 544K, and 624K units with 20.5 x 25 solid rubber tires; 644K and 724K units with 23.5 x 25 solid rubber tires; and 744K unit with 31.5 x 25 solid rubber tires.

