

Versatile, top-quality paving of poured-in-place profiles.

Slipform paver SP 15 / SP 15i



Outstanding features of the SP 15 / SP 15i slipform paver

02
03

1 |

HIGHLY FLEXIBLE OFFSET MOULD SYSTEM

Concrete feeding system offering a wide variety of adjustment options. Flexible arrangement of the offset mould on the left or right side, close to or far to one side of the machine frame. A wide variety of different offset moulds for poured-in-place profiles is available for a wide range of applications.

2 |

HIGH-QUALITY MACHINE CONTROL SYSTEM

High-quality machine control system for maximum operational reliability, precise machine functionality and automatic detection of configuration parameters and operating states.

10 |

INTELLIGENT TRANSPORT CONCEPT

Compact machine dimensions ensure ease of transport.

9 |

EASE OF OPERATION

Ergonomically designed operator's platform with self-explanatory operating concept for maximum productivity.

8 |

MODULAR ADAPTABILITY

Flexible arrangement of the paving mould and track units to ensure high machine utilization.

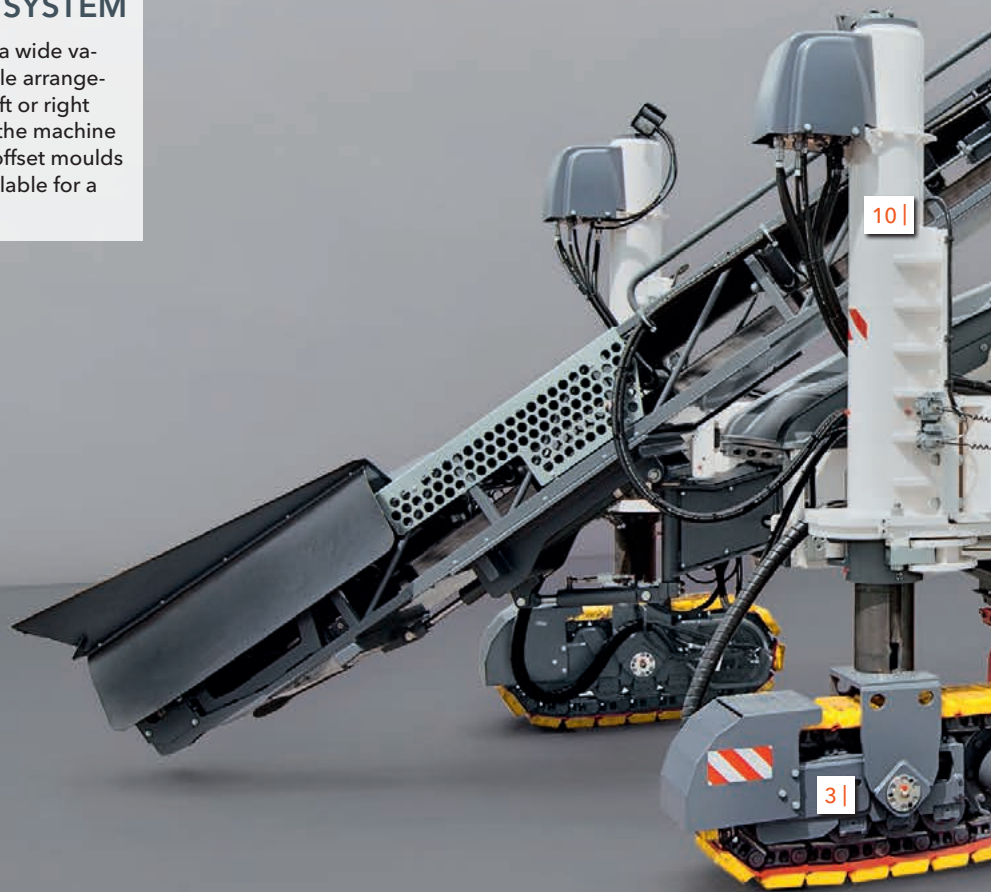

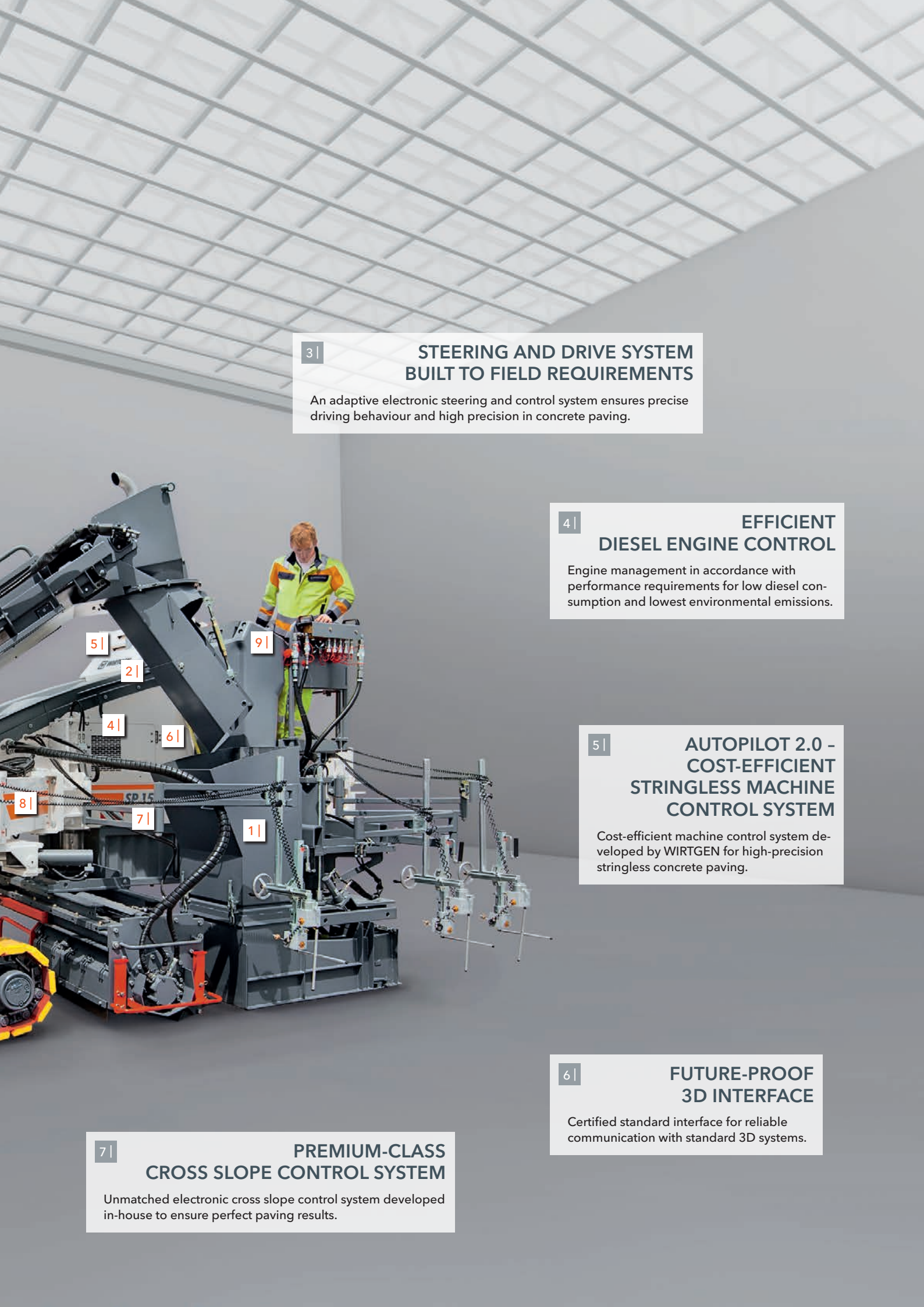

3 |

STEERING AND DRIVE SYSTEM BUILT TO FIELD REQUIREMENTS

An adaptive electronic steering and control system ensures precise driving behaviour and high precision in concrete paving.

4 |

EFFICIENT DIESEL ENGINE CONTROL

Engine management in accordance with performance requirements for low diesel consumption and lowest environmental emissions.

5 |

AUTOPILOT 2.0 - COST-EFFICIENT STRINGLESS MACHINE CONTROL SYSTEM

Cost-efficient machine control system developed by WIRTGEN for high-precision stringless concrete paving.

6 |

FUTURE-PROOF 3D INTERFACE

Certified standard interface for reliable communication with standard 3D systems.

7 |

PREMIUM-CLASS CROSS SLOPE CONTROL SYSTEM

Unmatched electronic cross slope control system developed in-house to ensure perfect paving results.

5 |

2 |

4 |

6 |

8 |

7 |

1 |

9 |





A new kind of

economic efficiency.

The WIRTGEN SP 15/ SP 15i slipform paver. Equipped with sophisticated features, customer-specific solutions, innovative machine technologies. And efficient multifunctionality. The compact machine boasts an unsurpassed variety of different applications in the paving of high-quality offset concrete profiles. SP 15/ SP 15i - undeniably WIRTGEN. Undeniably a champion.

- 1 | Flexible chute in steel or rubber design
- 2 | Pivoting legs for adjustment of the track units to site conditions
- 3 | Lifting column with hydraulic cylinder for height adjustment of the track units
- 4 | Concrete feeding system in belt conveyor or auger conveyor design offering various adjustment options
- 5 | Receiving hopper for freshly delivered concrete
- 6 | Hydraulically driven, separately height-adjustable and steerable track units
- 7 | Height-adjustable, laterally telescoping trimmer
- 8 | Offset mould, suitable for mounting on the left and right side of the paver, telescoping to both sides
- 9 | Quick-change mould-mounting system for kerb and gutter profiles
- 10 | Laterally telescoping rear track unit
- 11 | Walk-through operator's platform offering a good view of both the machine and the construction site
- 12 | Clearly structured control panel, suitable for mounting on the left or right side of the operator's platform
- 13 | Weather umbrella

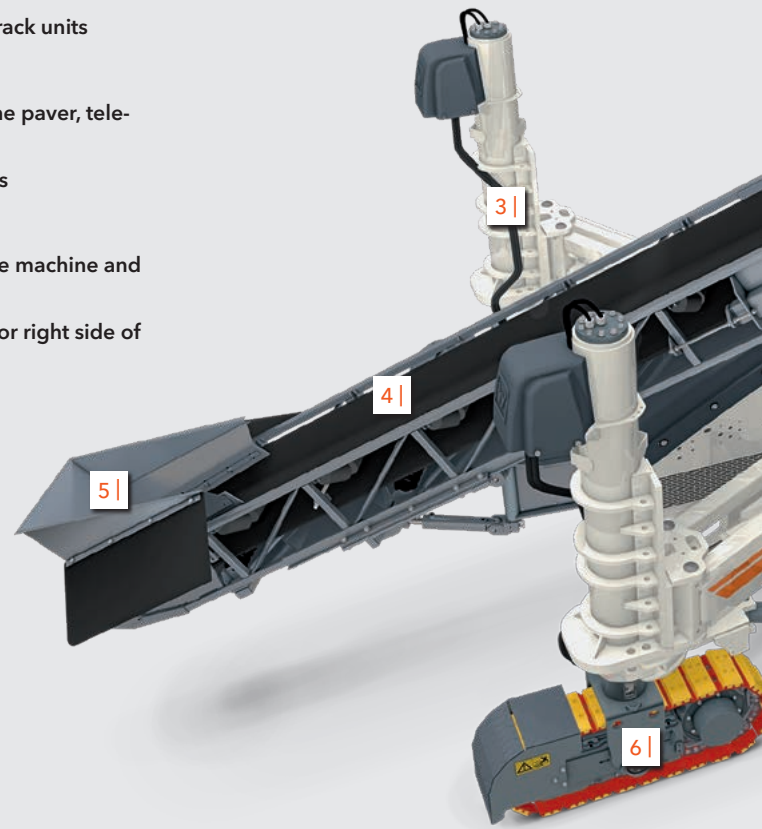

A striking array of performance features

WIDE RANGE OF OFFSET APPLICATIONS

The SP 15/SP 15i is second to none as a multi-purpose machine for offset concrete paving. It is the ideal choice for producing both poured-in-place profiles at heights of up to 1.3 m and concrete slabs at widths of up to 1.8 m. The slipform paver owes its wide range of applications to exceptional flexibility in positioning the paving mould and track units. Offset moulds in a wide variety of different profiles can be mounted either on the right or on the left side of the machine. The paver's flexibility is enhanced further by optional features such as the trimmer, concrete feeding by means of belt conveyor or auger conveyor, electric or hydraulic vibrators. This wealth of configura-

tion options enables the SP 15/SP 15i to be fully adjusted to site conditions and achieves a significant increase in productivity.

The compact SP 15/SP 15i impresses with its sturdy design for tough operating conditions, exceptional manoeuvrability and simple operating concept.

Intelligent electronic steering and control technology ensures full compliance with the specified requirements.

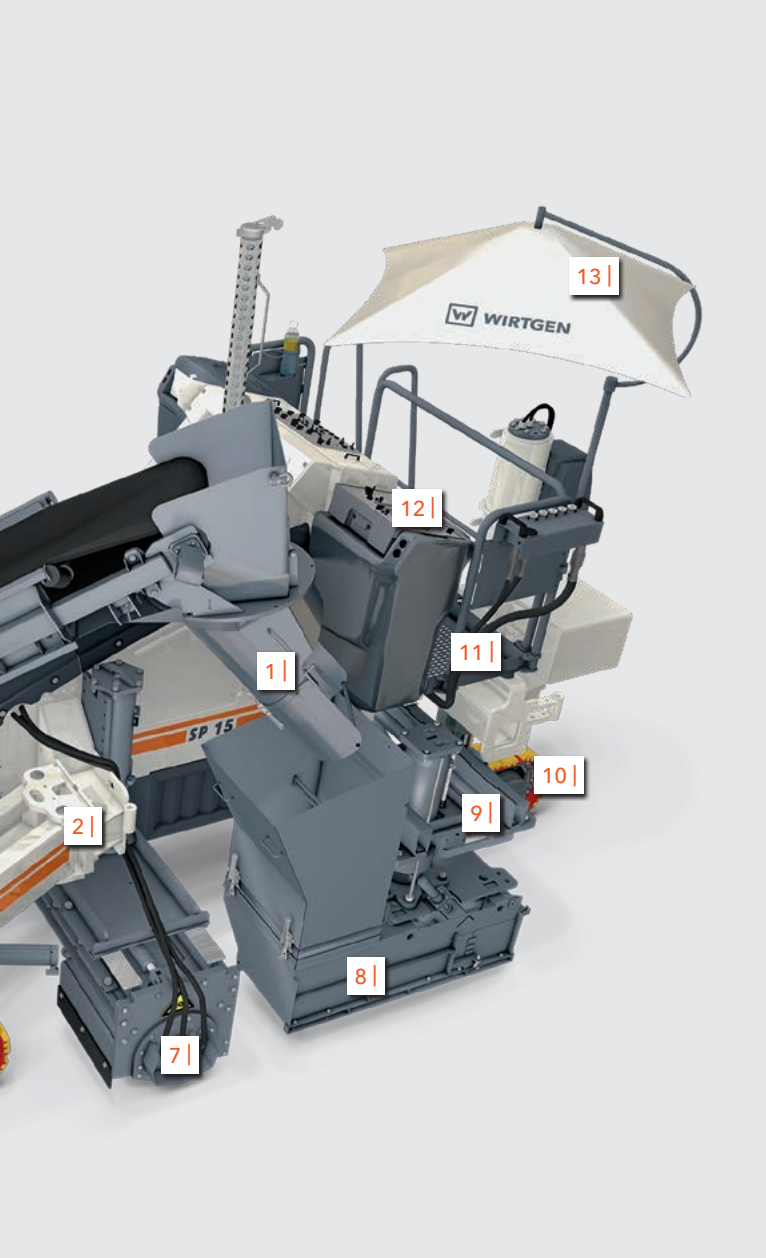

1 | Paving a sloped concrete shoulder.

2 | No problem for the SP 15/SP 15i: paving radii to pin-point accuracy.



11

1 | *Special parapet application for high containment performance: paving continuously reinforced concrete safety barriers both on the right ...*

High utilization rate due to a wide range of applications

THE SP 15/SP 15i IN ACTION

The SP 15/SP 15i is the perfect choice for paving large poured-in-place concrete profiles at heights of up to 1.3 m or widths of up to 1.8 m. Even larger profiles can be realized in accordance with customer requirements. A wide variety of different profile geometries can be produced, including kerbs, gutters, safety barriers, drains, sewers and narrow paths. Ease of transport enables the SP 15/SP 15i to perform different jobs on different construction sites during a single working day: changing moulds or switching

them from one side of the paver to the other is accomplished quickly and easily right on site. A trimmer can be mounted to create a perfect subgrade on construction sites presenting difficult ground conditions.

Flexible positioning of the paving mould, track units and concrete feeding system tremendously increases the range of applications of the SP 15/SP 15i. The paver's flexibility is enhanced even further by the telescoping mould mount and the addition of individual complementary features.



2 | ... and on the left side of the machine.

3 | Paving pedestrian and bicycle paths at widths of up to 1.8 m using a mould offering modular extension options.



4-5 | Paving small and large water gutters.

6 | Accurate paving of kerb and gutter profiles using the AutoPilot 2.0.

7 | Producing a slot drain to ensure rain-water drainage.



A man in a blue shirt and orange safety vest is operating a piece of machinery. A red hard hat is hanging on the machinery. The background is a clear blue sky.

**Standing here,
you're in charge.**

Be relaxed and comfortable during work while keeping everything in full view - a given with the SP 15/SP 15i. Clearly structured controls arranged with ergonomic principles in mind. Providing you with all relevant information at a single glance. The intelligent visibility concept comes as a standard feature. With the SP 15/SP 15i, you're always in command. Ease of operation and high productivity become one.



1 | Additional synergistic effects are created by the standardized, intuitive operating concept of the entire range of WIRTGEN slipform pavers.

Ease of operation enhances productivity

FAMILIAR WITH THE MACHINE IN NO TIME

The machine operator's well-being and performance are based on the ergonomic design of the spacious, walk-through operator's platform. The control panel of the SP 15/SP 15i can be positioned on the left or right side in accordance with job requirements, thus offering perfect visibility on both sides of the machine, paving process and construction site. The graphic screen on the control panel keeps the operator informed of all relevant operating parameters on an event-driven basis. Ease of operation is ensured by clear, language-independent symbols. These

features give the operator full control of the SP 15/SP 15i quickly, enabling him to work very effectively after only a short period of time.

A comprehensive lighting system turns the SP 15/SP 15i into a top performer even during night operations. Ample storage space is available for tools, sensors, the hydraulically operated high-pressure cleaner or other items needed on site.



2 | The convenient access ladder can be adjusted in height manually.

3 | Control panel suitable for mounting on the left or right side for perfect visibility.

4 | The graphic screen is incorporated in the centre of the clearly structured control panel.





Hidden intelligence.

While you are in command at the control panel of the SP 15/SP 15i, others are working in the background: innovative control technologies. Developed to precisely fit your specific requirements, based on our experience of many decades in this field. Tried-and-tested technologies. Autonomous, always wide awake. Hidden co-pilots that ensure ease of operation. That are intelligent. That manage, economize, boost performance. While you can fully focus on achieving work results of the highest quality. It all adds up.

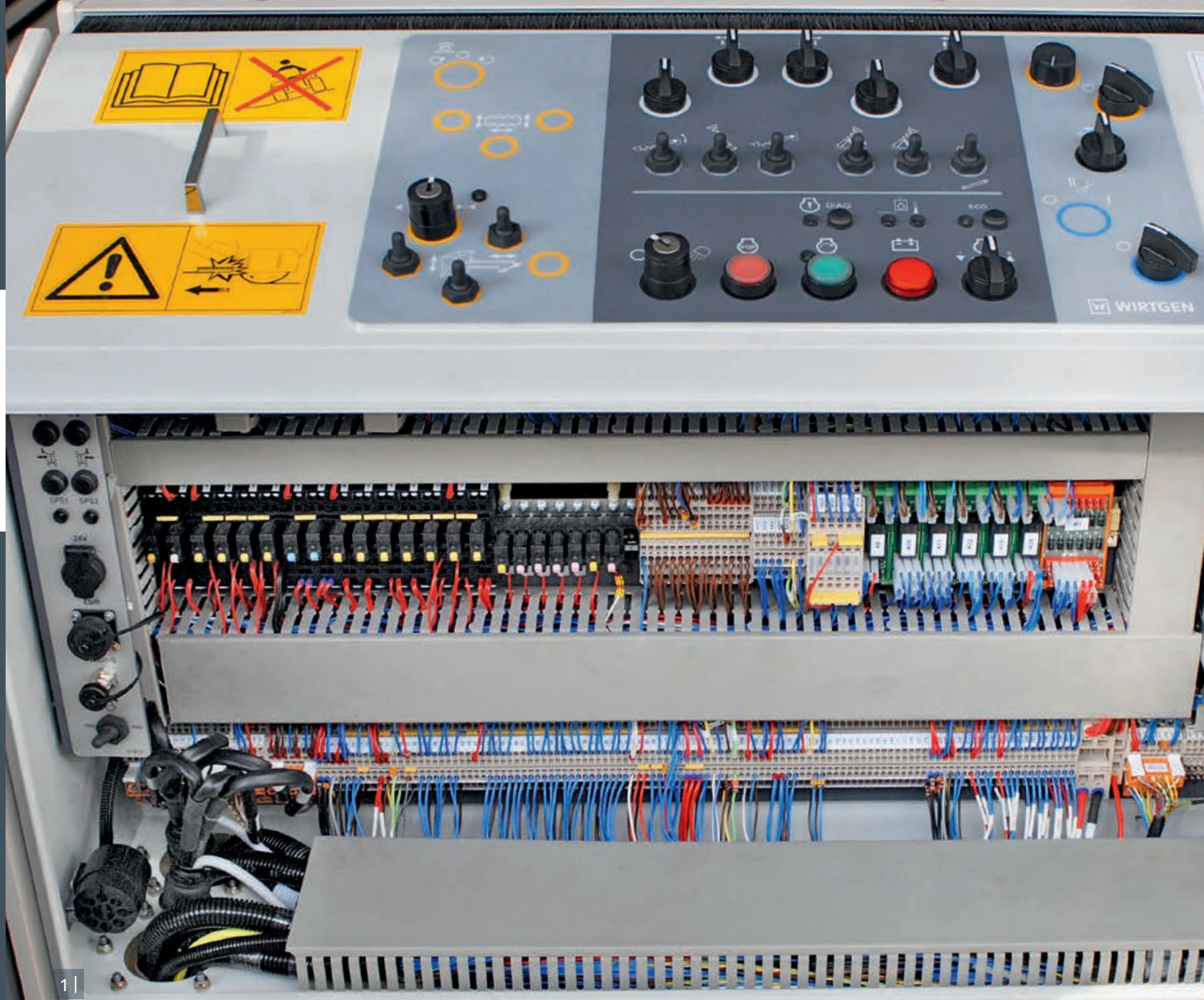

1 | Software developed in-house ensures high operational reliability.

Faultless operation - whatever the job

SOFTWARE AND HARDWARE

The SP 15/SP 15i slipform paver features an integrated machine control system of the highest quality, in which the large proportion of software developed in-house plays the decisive role. For the constant further development of the software guarantees maximum operational reliability of the machine. In addition, our many years of experience in software and hardware development allow for higher and more flexible machine functionality in terms of applications and meeting specific customer requirements.

Efficient engine management is an integral part of the machine control system. WIDIAG, the diagnostic system with standardized interface, is used by WIRTGEN service engineers for quick, specific service diagnostics right on site. In addition, the WIRTGEN WITOS FleetView telematics system supports fleet management, machine position and status monitoring, as well as maintenance and diagnostic procedures. In short: it is yet another key driver for improved efficiency in day-to-day operation.



2-3 | The high-quality machine control system guarantees perfect straight-ahead travel and precise steering in bends.

4 | Separate valves on the track units ensure high-precision height adjustment and steering control.

Precise driving behaviour - whatever the job

PRECISION IN CONCRETE PAVING GUARANTEED

The SP 15/SP 15i features an intelligent electronic steering and control system which offers everything it takes for precise driving behaviour and therefore high-precision concrete paving. The slipform paver comes into its own especially when working in bends. This is where the tried-and-tested Ackermann steering system ensures precise driving behaviour and therefore highest concrete quality. The computer-assisted steering system varies the speed of the individual track units during cornering, thus enabling the SP 15/SP 15i to follow the previously specified references with pinpoint accuracy. In addition, the steering angle positions of all track units are adjusted fully automatically based on the radius to be paved and the paver geometry. An unbeatable feature!

1 | *In stringless operation, the SP 15/SP 15i permits a paving radius of 500 mm - or less.*

The SP 15/SP 15i is capable of producing profiles with a minimum radius of only 500 mm. High-precision drive motor control guarantees smooth machine travel even when operating at extremely low speeds. The control system prevents spinning of the track units during cornering, maintaining optimum traction.

Additional steering modes - crab and coordinated - make easy work of repositioning and manoeuvring the slipform paver.



2 |



2 | Control panel with different steering mode settings for manoeuvring.

3 | Automatic adjustment of the steering angles and speeds of the individual track units to the paver's geometry.

3 |

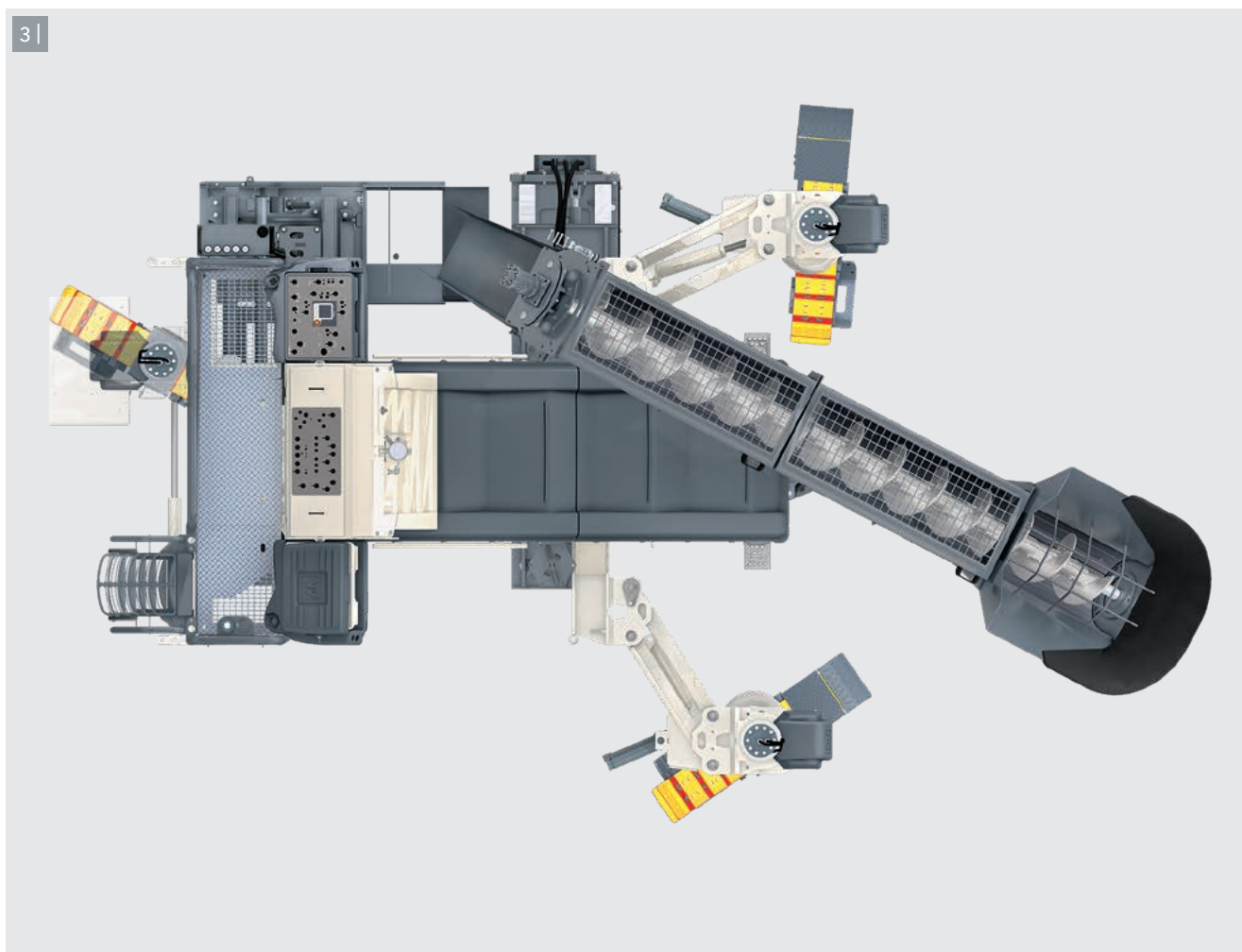

State-of-the-art engine technology

EFFICIENT DIESEL ENGINE CONTROL

Fuel consumption of the SP 15/SP 15i is minimized by the integrated ECO mode diesel engine control system. Upon activation of the ECO mode system, the engine speed is adjusted to the paver's performance requirements in an automated process. The engine operates at low speeds, for example, to match low machine advance rates, and at higher speeds to match the machine's increasing travel speed. High or maximum engine speeds are only required at high machine advance rates or when operating vibrators or a trimmer. The ECO mode system detects the current paving situation and optimizes the engine speed in accordance with the machine features used without the need for manual operator intervention.

1 | *The ECO mode engine control system enables the SP 15/SP 15i to always work in the optimum performance and torque ranges.*

The performance-based engine management system guarantees low diesel consumption, low noise emission levels and low operating costs.

The engine technology of the SP 15 complies with the specifications of exhaust emission standards EU Stage 3a/US Tier 3. The SP 15i features state-of-the-art engine technology for lowest environmental emission levels, complying with the strict specifications of exhaust emission standards EU Stage 4/US Tier 4f.

1 |



2 |

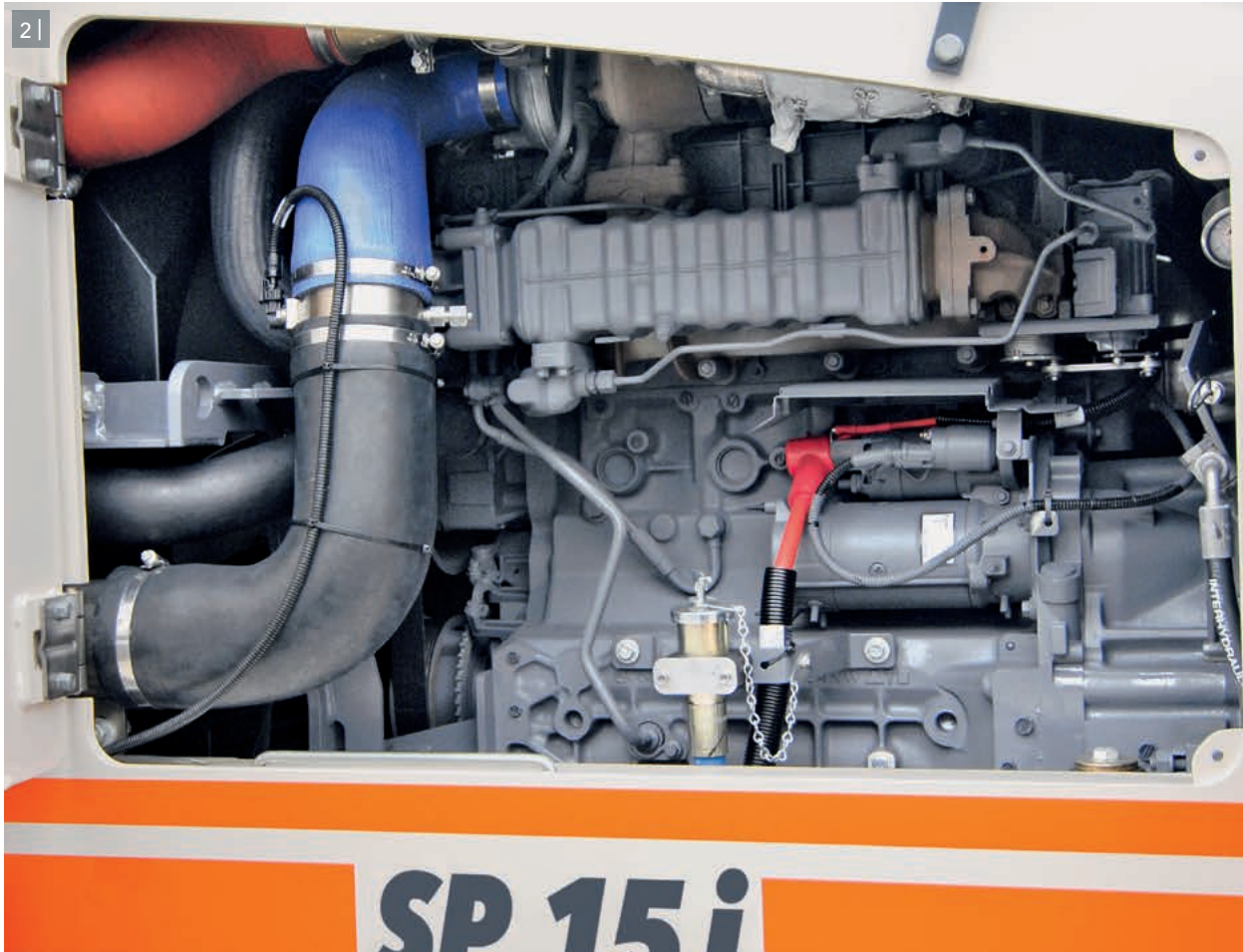

2 | The ECO mode engine control system guarantees low fuel consumption.

3 | Manual selection of the ECO mode system.



3 |



AutoPilot 2.0 – cost-efficient, stringless machine control system

22
23

WORK MORE EFFECTIVELY

The standard 3D machine control systems for producing poured-in-place concrete profiles by means of a slipform paver are frequently not a viable option especially for small contracting companies. This is mostly due to high investment costs, the level of technical support required in day-to-day operation, and the need to manage digital modelling data.

WIRTGEN provides customers with AutoPilot 2.0, an innovative and cost-efficient alternative system developed in-house, which eliminates these drawbacks. The system is based on GNSS (Global Navigation Satellite System) and has been precisely tailored for use with

the SP 15/SP 15i, assisting with the automated paving of a wide variety of different offset and inset concrete profiles, such as safety barriers on motorways or kerbs for traffic islands.

It requires no more than the uninterrupted reception of signals from a sufficiently large number of satellites and proficient use of the system including the Field Rover prism pole. Relevant points of the object to be paved are taught-in via a tablet computer on the Field Rover using software developed in-house. These are then used to compute a virtual stringline which is optimized for the slipform paving process and incorporates local conditions.

1 | *Stringless paving of poured-in-place profiles using the AutoPilot 2.0 system.*

2 | *The Field Rover is used to collect measuring points and perform check measurements.*

3 | *Following the successful calculation and verification of the virtual stringline, the tablet computer is placed into the docking station on the slipform paver.*

1 |



Unlike with to conventional 3D systems, the digital data model is created on the construction site. After connecting the tablet computer on the operator's platform of the paver, the specifications stored in the system can be executed immediately without requiring any intermediate steps. The operator remains in full control, however, and can intervene in the autonomous paving process whenever necessary. The system also permits the import of data, offering unique verification and intuitive editing functions.

Major advantage of the system: it dispenses with time-consuming surveying operations, the installation and removal of stringline, and the preparation of a geodetic data model.





1 |

1 | *WIRTGEN-specific acceptance procedures ensure safe application of the different 3D control systems.*

High-precision 3D control

2 | *Field-proven integrated standard interface for 3D control systems.*

MADE-TO-MEASURE PROFILE PAVING

Stringless control systems will drive the future of professional concrete paving. In addition to ensuring high paving accuracy, 3D control systems offer yet another major advantage: establishing the digital terrain models is much more cost-effective than surveying and the installation of stringline. The SP 15/SP 15i is all set for the job: an integrated standard

interface enables it to be fitted with a state-of-the-art external 3D control system in lieu of AutoPilot 2.0.

In thorough acceptance procedures, we have tested the compatibility of the SP 15/SP 15i with the 3D control systems of leading suppliers, thus ensuring safety of use. In addition, our own experts are working on continuously improving and perfecting the systems.

2 |



Unrivalled cross slope control

PERFECT PAVING QUALITY

Perfect paving results are guaranteed by the electronic cross slope control system developed by WIRTGEN on the basis of the "Rapid Slope" sensor.

Optimized control technology enables the innovative cross slope control system to achieve as yet unmatched dynamics and precision. Significantly shorter machine response times are reflected in the precision and quality of the completed concrete product.

The WIRTGEN cross slope control system can be relied on to level out any vibrations or ground irregularities in virtually no time at all.

1-2 | *Cross slope specifications are adhered to with pinpoint precision.*



2 |





In perfect shape for mastering the difficult jobs.



Everyday challenges in concrete paving operations. Fixed obstacles, restricted space. Difficult ground conditions, difficulties in concrete supply. The innovative WIRTGEN SP 15/SP 15i meets them all with made-to-measure, high-performance solutions. Offering unrivalled flexibility to adjust to the most diverse site conditions. With the fully modular machine design, for example, or the flexible mould system. Professional features making every job a success. The SP 15/SP 15i - and all's right with the construction world.



11

1 | *Three steerable track units enable the paver to turn on its own axis.*

Machine stability even in the toughest jobs

ADDING MODULAR FEATURES TO THE MACHINE FRAME

Seasoned slipform paver operators appreciate their machine's ability to reliably adjust to difficult site conditions. The SP 15/SP 15i is of fully modular design. Its track units offer extremely flexible adjustment options to provide the small slipform paver with perfect stability during operation. The paving mould and concrete feeding system can be adjusted to specific site conditions in accordance with requirements. In addition, the SP 15/SP 15i

can be easily modified, and complementary components can be added to cater to complex customer-specific applications. Customer options can also be retrofitted at any time using the standard interfaces incorporated in the machine.

The two front track units can be hydraulically pivoted about wide angles to allow full adjustment to site conditions. Flexibility on site is enhanced further by the paver's mechanically or hydraulically movable rear track unit.



2 | The rear track unit can be telescoped outwards ...

3 | ... to drive as close to the paving profile as possible, ensuring high machine stability.

4 | The track width of the two front track units can be adjusted via telescoping pivoting legs at the flick of a switch.



11

1 + 4 | The SP 15/ SP 15i is optionally equipped with a belt conveyor or auger conveyor.

Continuous concrete supply for high daily output rates

FLEXIBILITY IS THE KEY

The reliable, steady supply of concrete from the mixer truck to the paving mould is of vital importance for the successful paving of poured-in-place profiles. To meet this requirement, the SP 15/SP 15i is optionally equipped with an auger conveyor, belt conveyor or hydraulically folding belt conveyor shortening the paver's transport length. All three feeding systems offer flexible hydraulic adjustment to specific site conditions: in longitudinal direction, in their angle of incline, and about a slewing angle to feed the mould on the left or right side of the paver. The auger conveyor can be adjusted to significantly steeper

inclines of up to 45 degrees compared to the belt conveyor.

In addition, the auger conveyor is suitable for use as a buffer, offering capacity for holding larger concrete volumes.

As the auger conveyor is capable of holding large quantities of concrete, paving can continue even between concrete mixer loads.

Marks in favour of the belt conveyor are high conveying speed, good accessibility, and quick and easy cleaning.



2 |

2 | Hydraulic cylinders enable the feeding system to be slewed and adjusted in longitudinal position and incline.



3 |

3 | Concrete discharge: the rubber or steel chute can be positioned right above the hopper of the paving mould.



4 |

Positioning the paving mould according to requirements

MOUNTING ON THE RIGHT OR LEFT

The SP 15/SP 15i offers maximum flexibility regardless of the job to be completed. The paving mould can be mounted on the right or left side of the paver to meet different site requirements. This keeps traffic disruptions to a minimum as both the SP 15/SP 15i and the mixer truck are always moving with the flow of traffic.

A hydraulically telescoping mould mount enables the paving mould to be moved to either side, allowing profiles to be paved either within or outside the paver's dimensions. Height adjustment is effected via the track units, enabling a maximum profile paving height of 1,300 mm - unrivalled in this performance class.

The hydraulically operated quick-change mould-mounting system permits kerb and gutter profiles to be changed quickly and with only little effort.

1-2 | The paving mould can be telescoped outwards hydraulically by up to 700 mm.

3 | A quick-change mould-mounting system permits paving moulds to be changed quickly right on site.

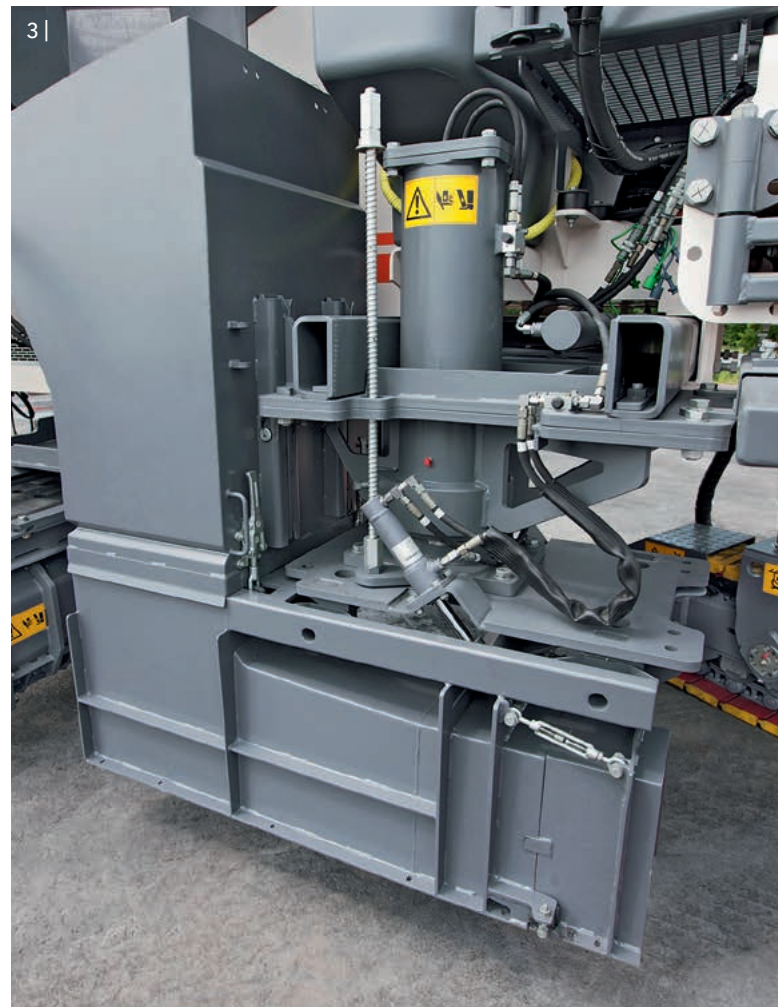

4 |



5 |



4 | Hydraulic stroke adjustment by up to 1,000 mm (additional mechanical adjustment: 280 mm).

5 | The mould can be mounted on the left or right - modification is completed within an extremely short time.

Perfect preparation of the base using a trimmer

1 | *The trimmer offers numerous adjustment options via hydraulic cylinders.*



2 | *The trimmer fine-grades the previously compacted base ...*



LEVEL BASE FOR A PERFECT PAVING PROCESS

The design of the trimmer is based on our unmatched expertise gained in several decades of experience in cutting technology.

The trimmer is fitted with picks arranged in a helical pattern, fine-grading an insufficiently level base to ensure uniform profile paving.

The trimmer is arranged right in front of the paving mould and can be adjusted in height

and cross slope as well as telescoped to either side. The unit has a basic width of 600 mm and can be extended in increments to a maximum width of 1,600 mm.

Customized solutions – such as a trimmer conveying the material towards the periphery of the machine – can also be realized.

3 | *... to a working depth of up to 150 mm.*





1 | Transport on a low-loader truck – a perfect match!

Intelligent transport concept

OPTIMIZED MACHINE DIMENSIONS

Excellent manoeuvrability and an exceedingly compact design speed up loading and transport of the SP 15/SP 15i slipform paver. Minimum effort is required to prepare the machine for transport. Paving moulds with small profile widths need not be removed but can remain mounted on the machine during transport.

With the mould in retracted position, the slipform paver complies with the maximum width permissible under applicable legislation. And when equipped with the folding belt conveyor, the SP 15/SP 15i can be transported with ease even on small transport vehicles.

2 | Compact dimensions: in retracted position, the small paving mould remains in place during transport.



3 | In folding design, the belt conveyor can be folded hydraulically for transport.



Technical specification

36
37

	SP 15	SP 15i
Range of applications	Offset paving	
Concrete feeding system		
Belt conveyor	Length: 4,900 mm; belt width: 600 mm	
Folding belt conveyor (option)	Length: 5,500 mm; belt width: 600 mm	
Auger conveyor (option)	Length: 4,600 mm; auger diameter: 400 mm	
Concrete paving mould		
Arrangement	Left/right	
Lateral adjustment of mould	700 mm	
Height adjustment of mould (option)	400 mm	
Max. mould height	1,300 mm ^{*1}	
Max. mould width	1,800 mm ^{*1}	
Vibration		
Connectors for hydraulic vibration	5	
Connectors for electric vibration (option)	5	
Trimmer unit (option)		
Standard width	600 mm	
Max. width	1,600 mm ^{*2}	
Working depth	0 to 150 mm	
Drum diameter with tools	500 mm	
Maximum lift	775 mm	
Hydraulic height adjustment	400 mm	
Mechanical height adjustment	375 mm	
Lateral adjustment of trimmer	1,300 mm	
Engine		
Engine manufacturer	Deutz	Deutz
Type	TCD 2012 L04 2V AG3	TCD 4.1 L4
Cooling	Water	Water
Number of cylinders	4	4
Rated power at 2,100 rpm	92 kW/123 HP/125 PS	95 kW/127 HP/129 PS
Displacement	4,040 cm ³	4,040 cm ³
Fuel consumption, full load	23.7 l/h	25 l/h
Fuel consumption, field mix	10.6 l/h	11.2 l/h
Exhaust emission standards	EU Stage 3a/US Tier 3	EU Stage 4/US Tier 4f
Electrical system		
Voltage supply	24 V	

^{*1} = Please consult factory for different offset geometries or special applications

^{*2} = Please consult factory for special widths

	SP 15	SP 15i
Filling capacities		
Fuel	220 l	
AdBlue® / DEF * ³	-	20 l
Hydraulic oil	220 l	
Water	220 l	160 l
Additional water tank	290 l	
Driving performance		
Operating speed	0 to 15 m/min	
Travel speed	0 to 35 m/min	
Track units		
Number of track units	3	
Track unit arrangement	2 x front / 1 x rear	
Dimensions (L x W x H)	1,340 mm x 260 mm x 550 mm	
Height adjustment of machine		
Hydraulic height adjustment	1,000 mm	
Mechanical height adjustment	280 mm	
Transport dimensions (L x W x H) *⁴		
Basic machine without concrete feeding system	5,400 mm x 2,400 mm x 2,650 mm	
Basic machine with belt conveyor	7,300 mm x 2,550 mm x 2,750 mm	
Basic machine with folding belt conveyor	6,700 mm x 2,550 mm x 2,950 mm	
Basic machine with auger conveyor	6,750 mm x 2,500 mm x 2,800 mm	
Belt conveyor without chute	5,500 mm x 1,050 mm x 680 mm	
Folding belt conveyor without chute	6,200 mm x 1,050 mm x 930 mm	
Auger conveyor without chute	5,100 mm x 1,150 mm x 1,000 mm	
Trimmer unit	2,200 mm x 800 mm x 1,680 mm	
Machine weights *⁵		
Empty weight of basic machine with belt conveyor	9,800 kg	
Operating weight, CE * ⁶ of basic machine with belt conveyor	10,350 kg	
Max. operating weight, full tanks, with trimmer, auger conveyor without paving mould	12,950 kg	
Trimmer unit, working width 600 mm	1,100 kg	
Belt conveyor	850 kg	
Folding belt conveyor	920 kg	
Auger conveyor	1,300 kg	

*³ = AdBlue® is a registered trademark of the Association of the Automotive Industry (Verband der Automobilindustrie e. V.; VDA)

*⁴ = All specifications are minimum specifications without offset mould mounted on the paver

*⁵ = Weights depend on the paver's range of equipment and working width

*⁶ = Weight of machine, half weight of all operating materials, machine operator (75 kg), on-board tools, no optional equipment features

Dimensions

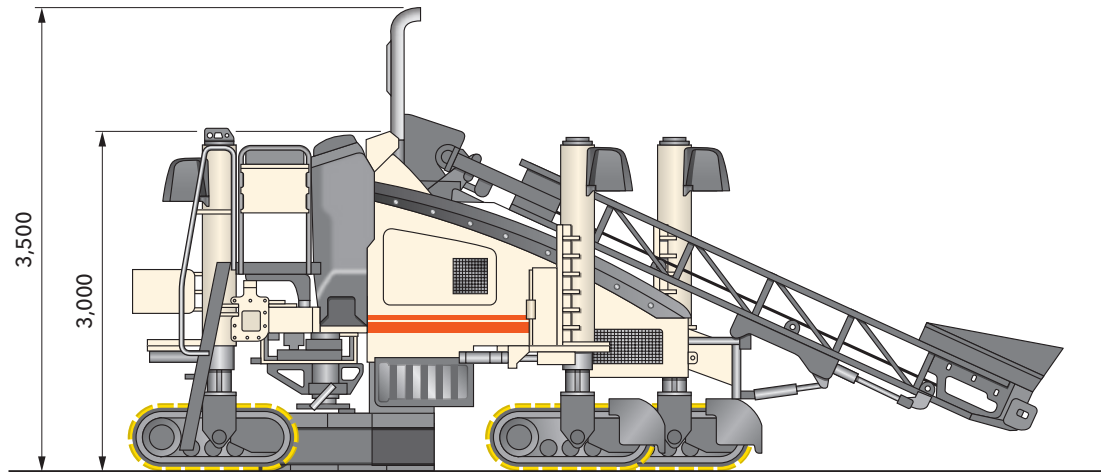

Direction of operation

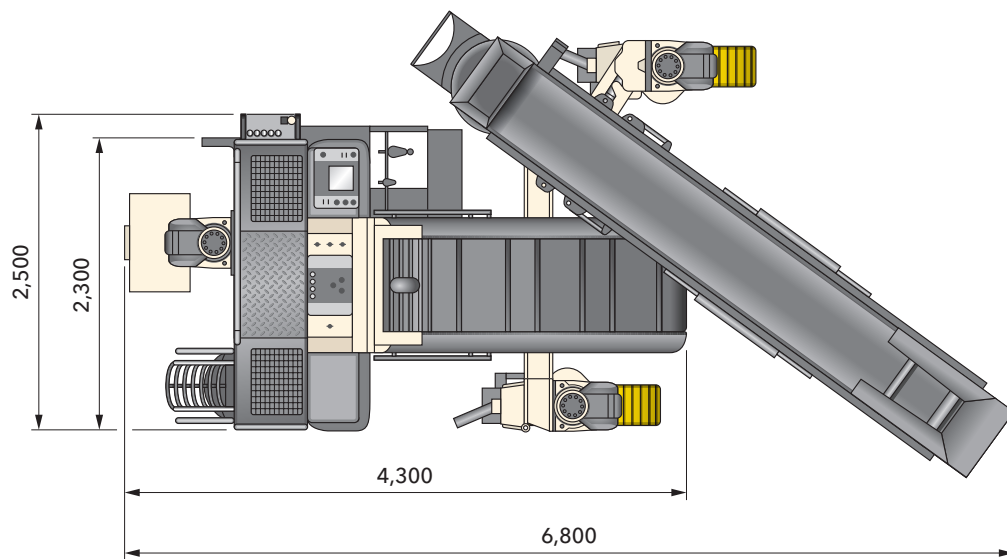

Incline of belt conveyor

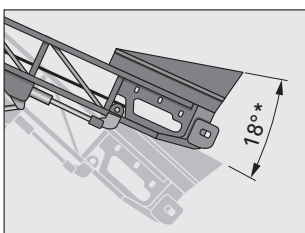

Longitudinal movement of belt conveyor

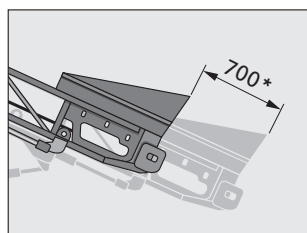

Transverse movement of belt conveyor

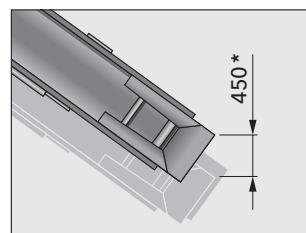

Slewing angle of belt conveyor

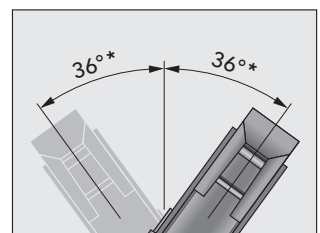

Dimensions in mm

* = Details also applicable to auger conveyor

Arrangement of track units and optional equipment features

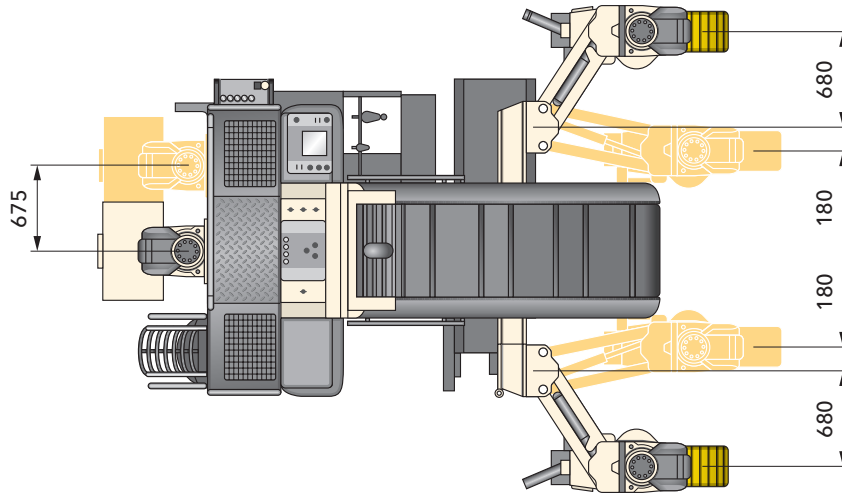

Direction of operation



Manoeuvring radius

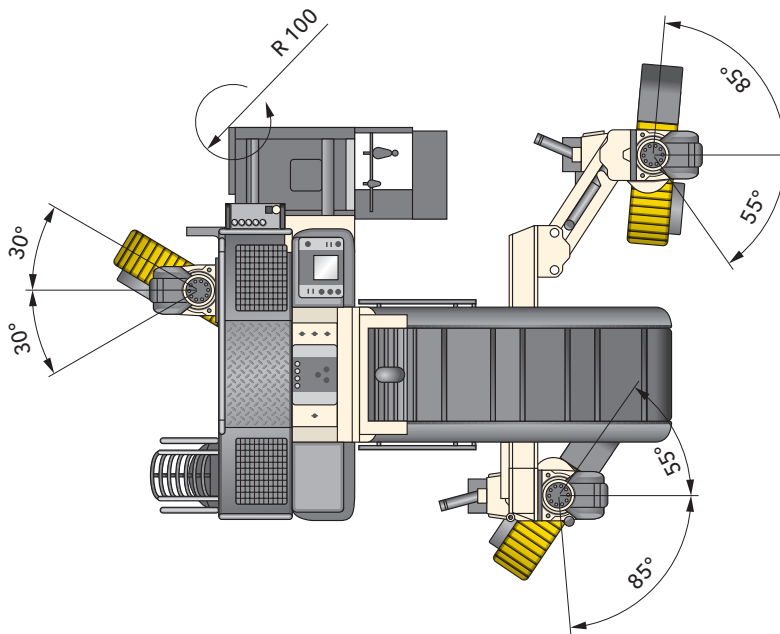

Paving radius applicable in operation

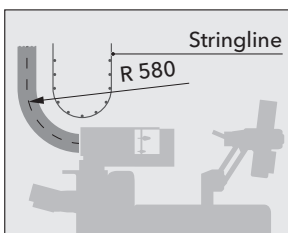

Paving radius on the stringline, offset mould retracted

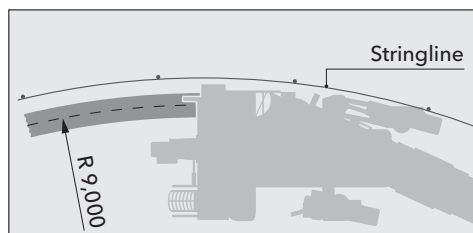

Paving radius on the stringline, offset mould extended

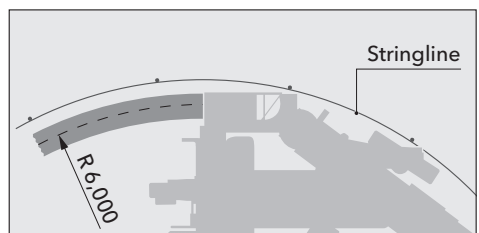

Standard equipment features

	SP 15	SP 15i
Basic machine		
Fuel tank, 220 l	■	■
Hydraulic oil tank, 220 l	■	■
Electrical system (24 V)	■	■
Pressure-and-flow-controlled hydraulic pump in the open circuit for driving the track units	■	■
Pressure-and-flow-controlled hydraulic pump in the open circuit for driving the hydraulic or electric vibrators	■	■
Pressure-controlled hydraulic pump in the open circuit for all cylinder functions	■	■
Proportionally controlled hydraulic pump, closed circuit, for driving the auger conveyor or belt conveyor	■	■
Main frame and height adjustment		
Sturdy machine frame for accommodating two track units at the front and one track unit at the rear	■	■
Chassis and chassis linkage		
Three hydraulically driven track units, 1.34 m long; gear ratio 1:42; including towing device	■	■
Continuously adjustable paving speed from 0 to 15 m/min	■	■
Continuously adjustable transport speed from 0 to 35 m/min	■	■
Three hydraulic levelling cylinders with a stroke of 1.00 m	■	■
The rear track unit can be moved along the rear suspension in order to select the most favourable position for the particular application	■	■
Model with one rigid and one pivoting front track unit connection (parallelogram arm)	□	□
Three track units fitted with triple-grouser steel track pads	□	□

- = Standard equipment
- = Standard equipment, replaceable with optional equipment
- = Optional equipment

	SP 15	SP 15i
Machine control, levelling and steering		
Digital control system with LCD display providing the operator with all pertinent information and allowing parameter settings, e.g. free choice of languages (D/GB/F/E/NL), to be made via a menu	■	■
Proportional electrohydraulic levelling and steering by means of a PLC system including two levelling sensors, two steering sensors and one slope sensor	■	■
Sensor mounting brackets, adjustable in height and range	■	■
Vibration		
Hydraulic vibrator drive for up to 5 vibrators	□	□
Two straight vibrators D66, hydraulically driven	□	□
Concrete feeding system		
Belt conveyor 4.90 m x 0.60 m with reversible hydraulic drive, hydraulically adjustable	□	□
Steel chute	□	□
Concrete equipment for offset paving		
The offset paving moulds can be mounted on the left or right side of the machine	■	■
The mould mount can be telescoped outwards by 0.70 m per side	■	■
Offset paving mould up to 0.60 m wide, max. height of 0.40 m	□	□
Miscellaneous		
Water tank with 220 l capacity and additional water tank with 290 l capacity	■	—
Water tank with 160 l capacity and additional water tank with 290 l capacity	—	■
Pre-fitting for installing the WITOS FleetView control unit	■	■
European design type certification, EuroTest mark and CE conformity	■	■
Standard painting in RAL 9001 (cream)	□	□
WITOS FleetView - professional telematics solution to optimize machine use and servicing	□	□
Lighting system including 3 halogen working lights, 24 V	□	□

■ = Standard equipment
 □ = Standard equipment, replaceable with optional equipment
 □ = Optional equipment

Optional equipment features

42
43

	SP 15	SP 15i
Chassis and chassis linkage		
Model with one rigid (spacer) and one pivoting front track unit connection (parallelogram arm)	<input type="checkbox"/>	<input type="checkbox"/>
Two pivoting front track units (parallelogram arms)	<input type="checkbox"/>	<input type="checkbox"/>
Three track units fitted with polyurethane track pads	<input type="checkbox"/>	<input type="checkbox"/>
Hydraulic positioning feature for the rear track unit	<input type="checkbox"/>	<input type="checkbox"/>
Machine control, levelling and steering		
Two slab tracers	<input type="checkbox"/>	<input type="checkbox"/>
Third height and steering sensor for paving in corners with tight radii	<input type="checkbox"/>	<input type="checkbox"/>
Pre-fitting for 3D levelling	<input type="checkbox"/>	<input type="checkbox"/>
AutoPilot 2.0 (868-870 MHz) with Field Rover	<input type="checkbox"/>	<input type="checkbox"/>
AutoPilot 2.0 (902-928 MHz) with Field Rover	<input type="checkbox"/>	<input type="checkbox"/>
Training for AutoPilot 2.0	<input type="checkbox"/>	<input type="checkbox"/>
Laser transmitter for AutoPilot 2.0 including stand	<input type="checkbox"/>	<input type="checkbox"/>
Laser receiver for AutoPilot 2.0	<input type="checkbox"/>	<input type="checkbox"/>
Ultrasonic sensor for AutoPilot 2.0	<input type="checkbox"/>	<input type="checkbox"/>
Total station Leica iCON robot 50 for AutoPilot 2.0	<input type="checkbox"/>	<input type="checkbox"/>
Additional tablet computer with case for AutoPilot 2.0	<input type="checkbox"/>	<input type="checkbox"/>
Vibration		
Electric vibrator drive with 10 kVA generator for up to 5 vibrators	<input type="checkbox"/>	<input type="checkbox"/>
Two curved vibrators D66, hydraulically driven	<input type="checkbox"/>	<input type="checkbox"/>
Two straight vibrators D66, electrically driven	<input type="checkbox"/>	<input type="checkbox"/>
Two curved vibrators D66, electrically driven	<input type="checkbox"/>	<input type="checkbox"/>
Straight vibrator D66, hydraulically driven	<input type="checkbox"/>	<input type="checkbox"/>
Curved vibrator D66, hydraulically driven	<input type="checkbox"/>	<input type="checkbox"/>
Straight vibrator D66, electrically driven	<input type="checkbox"/>	<input type="checkbox"/>
Curved vibrator D66, electrically driven	<input type="checkbox"/>	<input type="checkbox"/>
Concrete feeding system		
Belt conveyor 5.50 m x 0.60 m in folding design with reversible hydraulic drive, fully hydraulically adjustable	<input type="checkbox"/>	<input type="checkbox"/>
Auger conveyor 4.60 m x 0.40 m with reversible hydraulic drive, hydraulically adjustable	<input type="checkbox"/>	<input type="checkbox"/>
Steel-rubber chute	<input type="checkbox"/>	<input type="checkbox"/>
Concrete equipment for offset paving		
Offset paving mould from 0.60 m to 1.20 m wide, max. height of 0.40 m	<input type="checkbox"/>	<input type="checkbox"/>
Offset paving mould from 1.20 m to 1.80 m wide, max. height of 0.40 m	<input type="checkbox"/>	<input type="checkbox"/>
Offset paving mould up to 0.90 m high, max. base width of 0.60 m, including hopper	<input type="checkbox"/>	<input type="checkbox"/>
Offset paving mould up to 1.20 m high, max. base width of 0.60 m, including hopper	<input type="checkbox"/>	<input type="checkbox"/>
Split offset paving mould up to 0.60 m wide, max. height of 0.40 m	<input type="checkbox"/>	<input type="checkbox"/>
Split offset paving mould from 0.60 m to 1.20 m wide, max. height of 0.40 m	<input type="checkbox"/>	<input type="checkbox"/>

- = Standard equipment
- = Standard equipment, replaceable with optional equipment
- = Optional equipment

	SP 15	SP 15i
Concrete equipment for offset paving		
Bottom part for split offset paving mould (AV) up to 0.60 m wide (max. height of 0.40 m)	<input type="checkbox"/>	<input type="checkbox"/>
Bottom part for split offset paving mould (AV) from 0.60 m to 1.20 m wide (max. height of 0.40 m)	<input type="checkbox"/>	<input type="checkbox"/>
Set of hydraulic components for telescoping the offset mould mount	<input type="checkbox"/>	<input type="checkbox"/>
Height adapter for split offset paving moulds	<input type="checkbox"/>	<input type="checkbox"/>
Height-adjustable mould mount with 0.40 m lift for split offset mould	<input type="checkbox"/>	<input type="checkbox"/>
Hydraulic quick-change system for offset paving mould	<input type="checkbox"/>	<input type="checkbox"/>
Additional adapter plate for quick-change system	<input type="checkbox"/>	<input type="checkbox"/>
Set of hydraulic components for adjusting the sideplate of an offset paving mould	<input type="checkbox"/>	<input type="checkbox"/>
Offset trimmer		
Trimmer, basic width 0.60 m, for mounting on the left side	<input type="checkbox"/>	<input type="checkbox"/>
Trimmer, basic width 0.60 m, for mounting on the right side	<input type="checkbox"/>	<input type="checkbox"/>
Trimmer - extension, 0.20 m wide, for mounting on the left side	<input type="checkbox"/>	<input type="checkbox"/>
Trimmer - extension, 0.40 m wide, for mounting on the left side	<input type="checkbox"/>	<input type="checkbox"/>
Trimmer - extension, 0.20 m wide, for mounting on the right side	<input type="checkbox"/>	<input type="checkbox"/>
Trimmer - extension, 0.40 m wide, for mounting on the right side	<input type="checkbox"/>	<input type="checkbox"/>
Operator's platform		
Weather umbrella for operator's platform	<input type="checkbox"/>	<input type="checkbox"/>
Miscellaneous		
Painting in one special colour (RAL)	<input type="checkbox"/>	<input type="checkbox"/>
Painting in two special colours (RAL)	<input type="checkbox"/>	<input type="checkbox"/>
Painting in max. two special colours with the lower part of the machine painted in special colour (RAL)	<input type="checkbox"/>	<input type="checkbox"/>
High-performance lighting system including 3 LED working lights, 24 V	<input type="checkbox"/>	<input type="checkbox"/>
High-pressure cleaner	<input type="checkbox"/>	<input type="checkbox"/>
Large storage compartment at the rear of the machine	<input type="checkbox"/>	<input type="checkbox"/>
Wire tensioning system, complete with 1,000 m steel wire rope	<input type="checkbox"/>	<input type="checkbox"/>
Second tensioning winch for levelling the machine using two steel wire ropes	<input type="checkbox"/>	<input type="checkbox"/>
Wire tensioning system, complete with 4 x 300 m nylon rope	<input type="checkbox"/>	<input type="checkbox"/>
Radius kit, fibreglass rod as stringline replacement for paving in corners with different radii	<input type="checkbox"/>	<input type="checkbox"/>
Machine commissioning (day rate)	<input type="checkbox"/>	<input type="checkbox"/>

= Standard equipment
 = Standard equipment, replaceable with optional equipment
 = Optional equipment



WIRTGEN GmbH
Reinhard-Wirtgen-Str. 2 · 53578 Windhagen · Germany
Phone: +49 (0)26 45/131-0 · Fax: +49 (0)26 45/131-392
Internet: www.wirtgen.com · E-Mail: info@wirtgen.com

