

L-SERIES
TRACTOR LOADERS



JOHN DEERE

210L EP / 210L



VERSATILITY,
FRONT TO BACK

THE *L-SERIES*

GO-ANYWHERE

**LOADING, LIFT
AND MORE.**



+



RELIABLE + PRODUCTIVE

ING,





HUGELY POPULAR ON THE WEST COAST,
**OUR TRACTOR LOADERS ARE NOW
CATCHING ON EVERYWHERE.**

For years, John Deere “skip” loaders have been extremely popular on the West Coast. With their go-anywhere grading ability and operating ease, it’s no surprise these once “secret weapons” are becoming one of the worst-kept secrets in the business.

A key reason for their popularity is versatility. Our L-Series Tractor Loaders are more than just great grading machines. The economically priced 210L EP Tractor Loader offers plenty of capability for a wide variety of tasks. If you need more power and options, choose the 210L.

L-Series machines boast many customer-inspired enhancements to help maximize productivity and uptime, while lowering daily operating costs. Equip yours with a multipurpose bucket or multitude of other attachments, and you’ll have **what you need for whatever comes your way.**

DEPENDABLE, DURABLE, AND DOWN TO BUSINESS.

L-Series Tractor Loaders aren't modified backhoes, unlike many competitor offerings. These industrial-strength machines are purpose built for tractor-loader owners and their unique applications.

Lift more

Improved loader capacities allow for increased lifting and breakout forces. Get more done in a day with 26-percent-faster loader-lift cycle times and 17-percent more loader lifting, from 5,432 to 6,340 lb.

Proven engine technology

You can feel confident in the performance, fuel efficiency, and reliability of the Deere 210L EP's proven Yanmar 3.3L engine. This IT4-equivalent diesel complies with FT4 emissions regulations without the need for aftertreatment components, minimizing machine complexity and the number of parts needed to maintain your fleet.

Powerful FT4 engine

Rugged FT4/Stage IV PowerTech™ Plus diesel for the 210L meets rigid emissions regulations, enabling you to work, wherever there's work — even in nonattainment areas. Our field-proven technology is simple, fluid efficient, fully integrated, and fully supported. It employs cooled exhaust gas recirculation (EGR) and selective catalytic reduction (SCR).

Better resale value

You'll profit from proven John Deere advantages such as smooth and responsive hydraulics, exceptional reliability, low daily operating costs, and unsurpassed resale.

More durable components

Larger-diameter hitch-pitch and tilt cylinder pins improve durability, for long life. Optional transmission guard provides more protection from stones, stumps, and debris, while preventing material accumulation when backing over the pile.

Hydraulically actuated clutch packs

Clutch packs are hydraulically actuated to deliver more reliable performance, regardless of operating conditions and load.



FT4

**EPA FINAL TIER 4 (FT4)/
EU STAGE IV POWERTECH
PLUS DIESEL ENGINE***

**EPA Interim Tier 4 (IT4)-equivalent Yanmar on the 210L EP.*





COMFORT, CONVENIENCE, AND CONTROL

TAKE A TURN FOR THE BETTER.

With customer-inspired enhancements such as increased seat rotation and an ergonomic loader grip, our operator stations once again set the standard for comfort and ease of control. Whether equipped with a canopy or optional four-season air-conditioned/heated cab, L-Series machines help beat fatigue and boost productivity.



OUTSTANDING BOX-BLADE VIEW

More comfort and visibility

Right-hand armrest is larger and more comfortable. Seat rotation has been increased from 50 to 70 deg. for a better view to the box blade and easier machine entry and exit. Unrestricted visibility out the front and rear is even more expansive.

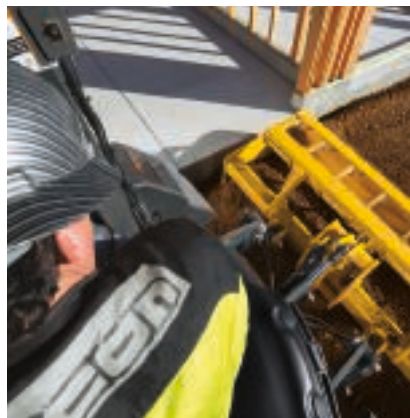

Vital info at a glance

Easy-view monitor displays important operating information at a glance. Available passcode-enabled security system helps prevent unauthorized machine movement.

Easy-to-use loader-control grip

"Palm-on-top" loader-control grip is extremely comfortable and easy to use. Optional control of clutch disconnect, auxiliary proportional roller, and momentary mechanical-front-wheel drive is at your fingertips.

Elevated canopy platform

Higher canopy with wider and lower step provides better visibility over the hood and to the corners of the front bucket, as well as to the rear box blade. Makes it easier to service under-canopy components, too.

Smooth-shifting PowerShift™ transmission

Exclusive PowerShift transmission allows smooth no-clutch fingertip shifting and direction changes for fast work cycles.



TASKS.
MASTERED.

DESIGNED AND BUILT

FOR YOUR MULTIPLE PURPOSES.

Whether you do earthwork or roadwork, land clearing or landscaping — if it's a versatile heavy-duty tractor loader you need, get an L-Series.

More rear-weight options

700- and 1,500-lb. rear ballast-weight packages give you more versatility to customize your machine to your application. 700-lb. hitch-weight package is now compatible with the power takeoff (PTO) option (210L only), for even greater versatility.

On-the-fly MFWD with optional limited-slip front axle

Mechanical-front-wheel drive (MFWD) and differential lock can be engaged on-the-go to give extra traction in poor underfoot conditions or for moving heavy loads. Optional limited-slip front axle delivers 65 percent of available power to the tire with the best traction for true all-wheel-drive pulling power.

Increased hitch range of motion and control

Hitch design makes it easier to position the box blade over the pile, for more versatility and productivity. Optional dual-tilt rear hydraulic cylinders provide greater three-point side-to-side hitch control of the rear attachments.

Work our connections

Equipped with an optional loader coupler or three-point hitch coupler, L-Series Tractor Loaders accept numerous productivity-enhancing attachments. Integral three-point hitch and optional PTO accommodate a variety of Category 2 tools such as disks, mowers, blades, and box scrapers.

See more, do more

Improved fender design and light positioning provide better visibility around the canopy.

Extend your workday

Premium LED lighting package option for canopy units includes two front spotlights and two rear and two side floodlights, for enhanced visibility to the rear work tools in low- or no-light conditions.

PREMIUM LED LIGHTING PACKAGE



CHEAP UPKEEP

MORE SAVINGS. LESS HASSLE.

No DPF

No diesel particulate filter (DPF) is needed on either model, reducing downtime and expense.

Quiet, fuel-efficient fan

Variable-speed electronically controlled fan on the 210L automatically speeds up or slows down, operating only as needed to keep things cool. Also helps conserve power and fuel, while reducing noise. Viscous variable-speed fan is standard on the 210L EP.

Maintenance-free batteries

Standard maintenance-free batteries improve cold-starting reliability, reduce periodic service, and lengthen battery life.

Same-side ground-level service

Two-position tilt hood provides same-side ground-level access to engine and transmission dipsticks, engine-oil fill, fuel and air filters, and coolant reservoir. Fuel fill is also conveniently close.

Easy clean-out coolers

Hydraulic and transmission coolers mounted in the mainframe are unhinged. Radiator, charge air, fuel, and A/C condenser coolers are in the front, if equipped.

Onboard diagnostics

If something goes wrong, the multi-language monitor displays easy-to-understand diagnostic information about the issue, along with a trouble code, to help get you back up and running quickly.

Reversible router bits extend wear

Router bits are reversible, for double the life.



Get valuable insight with
JOHN DEERE WORKSIGHT™

John Deere WorkSight is an exclusive suite of telematics solutions that increases uptime while lowering operating costs. At its heart, JDLink™ machine monitoring provides real-time utilization data and alerts to help you maximize productivity and efficiency while minimizing downtime. Remote diagnostics enable your dealer to read codes and record performance data without a trip to the jobsite.

Keep downtime down with
JOHN DEERE ULTIMATE UPTIME

John Deere Ultimate Uptime, featuring John Deere WorkSight, is a customizable support solution available exclusively from your Deere dealer. This flexible offering maximizes equipment availability with standard John Deere WorkSight capabilities that can help prevent future downtime and speed repairs when needed. In addition to the base John Deere WorkSight features, our dealers work with you to build an uptime package that meets the specific needs of your machine, fleet, project, and business, including customized maintenance and repair agreements, onsite parts availability, extended warranties, fluid sampling, response-time guarantees, and more.





210L EP / 210L SPECIFICATIONS

Engine	210L EP		210L	
Manufacturer and Model	Yanmar 4TNV98CT turbocharged		John Deere PowerTech™ Plus 4045HT082 turbocharged	
Non-Road Emission Standard	EPA Interim Tier 4 equivalent, EPA Final Tier 4 compliant		EPA Final Tier 4/EU Stage IV	
Displacement	3.3 L (203 cu. in.)		4.5 L (276 cu. in.)	
Gross Peak Power	54 kW (72 hp) at 2,330 rpm		71 kW (95 hp) at 2,244 rpm	
Power Ratings				
Net Peak Power (ISO 9249)	51 kW (69 hp) at 2,010 rpm		69 kW (93 hp) at 2,244 rpm	
Net Peak Torque (ISO 9249)	271 Nm (200 lb.-ft.) at 1,800 rpm		383 Nm (282 lb.-ft.) at 1,400 rpm	
Net Torque Rise	27%		28%	
Lubrication	Pressure system with spin-on filter and cooler		Pressure system with spin-on filter and cooler	
Air Cleaner	Dual-stage dry type with safety element and evacuator valve			
Cooling				
Fan Type	Viscous variable-rate (temperature controlled) cooling fan standard		Electronically controlled, variable rate, suction type cooling fan	
Engine Coolant Rating	-40 deg. C (-40 deg. F)		-40 deg. C (-40 deg. F)	
Engine Oil Cooler	Oil to water		Oil to water	
Powertrain				
Transmission	4-speed, helical-cut gears, full PowerShift™ transmission with hydraulic reverser standard; electric clutch cutoff on loader lever			
Torque Converter	Single stage, dual phase with 2.63:1 stall ratio, 280 mm (11 in.)			
Maximum Travel Speeds with PowerShift Transmission, Measured with 16.9L-24 Rear Tires	<i>Forward</i>	<i>Reverse</i>	<i>Forward</i>	<i>Reverse</i>
Gear 1	5.2 km/h (3.2 mph)	6.6 km/h (4.1 mph)	5.0 km/h (3.1 mph)	6.4 km/h (4.0 mph)
Gear 2	9.7 km/h (6.0 mph)	12.2 km/h (7.6 mph)	9.3 km/h (5.8 mph)	11.7 km/h (7.3 mph)
Gear 3	19.9 km/h (12.4 mph)	—	19.1 km/h (11.9 mph)	—
Gear 4	36.2 km/h (22.5 mph)	—	34.5 km/h (21.4 mph)	—
Axles				
Axle Oscillation, Stop to Stop, Front Axle	22 deg.		22 deg.	
Axle Ratings	<i>Front</i>	<i>Rear</i>	<i>Mechanical-Front-Wheel Drive (MFWD)</i>	<i>Rear</i>
SAE J43	5000 kg (11,000 lb.)	6000 kg (13,200 lb.)	4500 kg (9,921 lb.)	6000 kg (13,200 lb.)
Dynamic	9000 kg (19,800 lb.)	10 000 kg (22,000 lb.)	8500 kg (18,739 lb.)	10 000 kg (22,000 lb.)
Static	23 500 kg (51,800 lb.)	26 500 kg (58,400 lb.)	23 500 kg (51,809 lb.)	26 500 kg (58,400 lb.)
Ultimate	37 000 kg (81,600 lb.)	39 500 kg (87,100 lb.)	37 000 kg (81,571 lb.)	41 500 kg (91,500 lb.)
Differentials				
MFWD Axle	Open – standard; automatic, limited-slip traction control – custom or optional			
Rear Axle	Foot actuated, hydraulically engaged 100% mechanical lock			
Steering (ISO 5010)				
Axle	Hydrostatic power steering and emergency steering		Hydrostatic power steering and emergency steering	
	<i>MFWD</i>		<i>MFWD</i>	
Curb-Turning Radius				
With Brakes	3.58 m (11 ft. 9 in.)		3.58 m (11 ft. 9 in.)	
Without Brakes	4.24 m (13 ft. 11 in.)		4.24 m (13 ft. 11 in.)	
Bucket-Clearance Circle				
With Brakes	10.23 m (33 ft. 7 in.)		10.23 m (33 ft. 7 in.)	
Without Brakes	11.19 m (36 ft. 9 in.)		11.19 m (36 ft. 9 in.)	
Steering Wheel Turns (lock to lock)	2.7		2.7	
Brakes (ISO 3450)				
Service	Power assisted, hydraulic wet disc, mounted inboard, self-adjusting and self-equalizing			
Parking	Spring applied, hydraulically released, wet, multi-disc, independent of service brakes with electric switch control			
Hydraulics				
Main Pump	Open-center system; axial-piston pump		Open center, single-gear pump, integral priority valve	
Pump Flow, Hitch and Loader	104 L/m (27.5 gpm) at 2,200 rpm		96 L/m (25.3 gpm) at 2,250 rpm	
System Relief Pressure	22 063 kPa (3,200 psi)		22 063 kPa (3,200 psi)	

210L EP / 210L SPECIFICATIONS



Hydraulics <i>(continued)</i>		210L EP	210L
Hitch Hydraulic Cycle Time			
Hitch Raise (full stroke)		1.9 sec.	1.5 sec.
Hitch Lower (to ground level)		0.9 sec.	1.2 sec.
Pitch Down		1.9 sec.	1.6 sec.
Pitch Up		2.2 sec.	1.6 sec.
Tilt Up		1.5 sec.	1.4 sec.
Tilt Down		1.7 sec.	1.2 sec.
Loader Hydraulic Cycle Time			
Boom Raise to Full Height		4.7 sec.	5.1 sec.
Bucket Dump at Maximum Height		1.6 sec.	2.4 sec.
Boom Lower (power down)		2.4 sec.	3.4 sec.
Controls			
Hitch	4-lever, single tilt cylinder; 5-lever dual tilt (includes auxiliary) optional		
Loader	Single-lever loader/bucket control with electric clutch cutoff switch; separate-lever loader auxiliary function optional; single-lever loader/auxiliary with metered roller switch for auxiliary optional		
Cylinders		210L EP / 210L	
Heat-treated, chrome-plated, polished rods; hardened steel (replaceable bushings) pivot pins			
	<i>Bore</i>	<i>Rod Diameter</i>	<i>Stroke</i>
Loader Boom (2)	80.0 mm (3.15 in.)	50.0 mm (1.97 in.)	790.0 mm (31.10 in.)
Loader Bucket (1)	90.0 mm (3.54 in.)	50.0 mm (1.97 in.)	744.0 mm (29.29 in.)
Hitch Lift (1)	80.0 mm (3.15 in.)	50.0 mm (1.97 in.)	254.0 mm (10.00 in.)
Hitch Pitch (1)	63.5 mm (2.50 in.)	31.8 mm (1.25 in.)	196.9 mm (7.75 in.)
Hitch Tilt (1 or 2)	76.2 mm (3.00 in.)	50.8 mm (2.00 in.)	120.7 mm (4.75 in.)
MFWD (1)	65.0 mm (2.56 in.)	40.0 mm (1.57 in.)	210.0 mm (8.27 in.)
Electrical		210L EP	210L
Voltage		12 volt	12 volt
Alternator Rating		130 amp with canopy or cab	130 amp with canopy / 150 amp with cab
Lights		4 halogen: 2 front and 2 optional rear (32,500 candlepower each); turn signals and flashers, 2 front and 2 rear; stop- and taillights; 2 front amber and 2 rear reflectors; 6-LED-light option: 2 front, 2 side, and 2 rear	
Operator Station		210L EP / 210L	
Type (SAE J1040)	Standard canopy: solid-mounted ROPS/FOPS, left access, with 2-post ROPS and steel roof / optional cab: isolation-mounted ROPS/FOPS, left access, with molded roof and standard HVAC		
Seat Rotation	<i>Standard</i>	<i>Optional</i>	
Left	10 deg.	20 deg.	
Right	40 deg.	50 deg.	
Tires/Wheels		<i>Front</i>	<i>Rear</i>
With MFWD		12X16.5 12 PR, heavy-side-wall traction	16.9-24 142A8 LI, 8-ply equivalent (R4)
Serviceability		210L EP	210L
Refill Capacities			
Cooling System			
Cab		19.3 L (20.4 qt.)	30.0 L (31.7 qt.)
Canopy		17.4 L (18.4 qt.)	28.2 L (29.8 qt.)
Rear Axle		18 L (19 qt.)	18 L (19 qt.)
Engine Oil (including vertical spin-on filter)		10.5 L (11.1 qt.)	13 L (13.7 qt.)
Torque Converter and Transmission		15.1 L (16 qt.)	15.1 L (16 qt.)
Fuel Tank (with ground-level fueling)		117.3 L (31 gal.)	117.3 L (31 gal.)
Diesel Exhaust Fluid (DEF) Tank		—	16.3 L (4.3 gal.)
Hydraulic System		111.7 L (29.5 gal.)	111.7 L (29.5 gal.)
Hydraulic Reservoir		45 L (11.9 gal.)	45 L (11.9 gal.)
MFWD Housing			
Axle		6.5 L (6.9 qt.)	6.5 L (6.9 qt.)
Planetary (each)		0.9 L (1 qt.)	0.9 L (1 qt.)

210L EP / 210L

Operating Weights	210L EP	210L
With Full Fuel Tank, 79-kg (175 lb.) Operator, and Standard Equipment	4794 kg (10,569 lb.)	5137 kg (11,326 lb.)
Typical with Canopy, MFWD, Single Battery, 2x4 Valve, 0.86-m ³ (1.125 cu. yd.) Loader Bucket, 454-kg (1,000 lb.) Wheel Weights, Deluxe Electrical, and 2134-mm (84 in.) Box Blade	6100 kg (13,449 lb.)	6444 kg (14,206 lb.)
Optional Components		
Cab (weight difference between canopy and cab)	363 kg (800 lb.)	363 kg (800 lb.)
Box Blade		
2134 mm (84 in.)	771 kg (1,700 lb.)	771 kg (1,700 lb.)
2235 mm (88 in.)	816 kg (1,800 lb.)	816 kg (1,800 lb.)
Wheel Weights	454 kg (1,000 lb.)	454 kg (1,000 lb.)
Hitch Weights	318 kg (700 lb.) / 681 kg (1,500 lb.)	318 kg (700 lb.) / 681 kg (1,500 lb.)
Front Loader Coupler	286 kg (630 lb.)	286 kg (630 lb.)
Overall Dimensions	210L EP / 210L	
A Ground Clearance, Minimum	262 mm (10.3 in.)	
B Overall Length, Transport (without box blade)	5.31 m (17 ft. 5 in.)	
C Transport Height		
Canopy	2.62 m (8 ft. 7 in.)	
Cab	2.64 m (8 ft. 8 in.)	
D Length from Axle to Axle (MFWD axle)	2.16 m (7 ft. 1 in.)	
E Width Over Tires	2.13 m (7 ft. 0 in.)	
3-Point Hitch Dimensions and Performance		
Hitch Downforce (excluding attachment weight)	8 kN (1,790 lb.)	
Lift Capacity, Static at Lower Link	3917 kg (8,629 lb.)	
Lower Hitch Point Height		
Maximum	780 mm (30.7 in.)	
Minimum	213 mm (8.4 in.)	

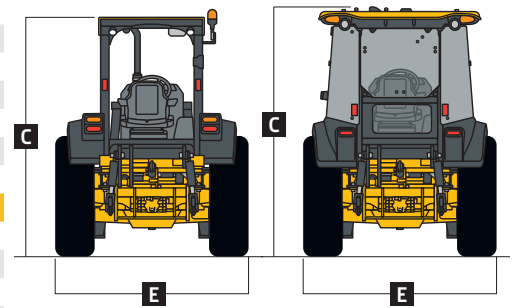

210L EP/210L with Canopy 210L EP/210L with Cab

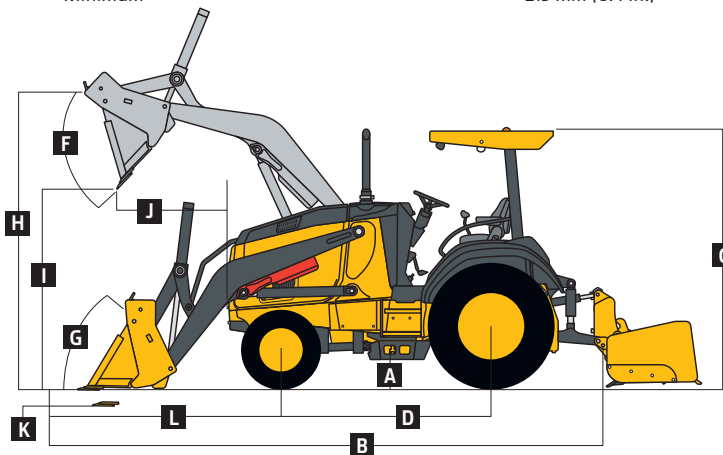

210L EP/210L Tractor Loader with Canopy

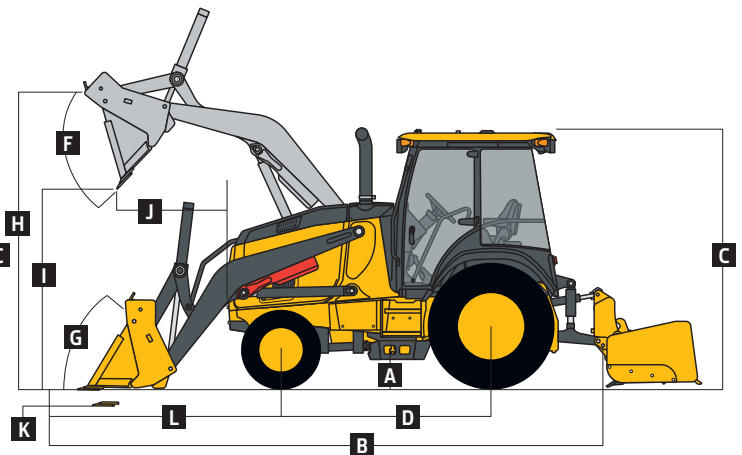

210L EP/210L Tractor Loader with Cab

Loader Dimensions and Performance		210L EP / 210L	
F	Bucket Dump Angle, Maximum	45 deg.	
G	Rollback Angle at Ground Level	40 deg.	
Bucket		<i>Heavy-duty</i>	<i>Multipurpose</i>
	Capacity	0.86 m ³ (1.12 cu. yd.)	0.96 m ³ (1.25 cu. yd.)
	Width	2184 mm (86 in.)	2184 mm (86 in.)
	Weight	390 kg (860 lb.)	795 kg (1,750 lb.)
	Breakout Force (with wheel weights and box blade)	42.3 kN (9,521 lb.)	36.7 kN (8,245 lb.)
	Lift Capacity, Full Height (with wheel weights and box blade)	2876 kg (6,340 lb.)	2529 kg (5,575 lb.)
H	Height to Bucket Hinge Pin, Maximum	3.36 m (11 ft. 0 in.)	3.36 m (11 ft. 0 in.)
I	Dump Clearance, Bucket at 45 deg.	2.66 m (8 ft. 9 in.)	2.56 m (8 ft. 5 in.)
J	Reach at Full Height, Bucket at 45 deg.	765 mm (30.1 in.)	803 mm (31.6 in.)
K	Digging Depth Below Ground, Bucket Level	197 mm (7.8 in.)	238 mm (9.4 in.)
L	Length from Front Axle Centerline to Bucket Cutting Edge	2.04 m (6 ft. 8 in.)	2.16 m (7 ft. 1 in.)

Lift Capacity with Quick-Coupler Forks			
Hydraulic Capacity	1219-mm (48 in.) Tines	1524-mm (60 in.) Tines	
A	Maximum Height	1664 kg (3,668 lb.)	1548 kg (3,413 lb.)
B	Maximum Reach	2667 kg (5,880 lb.)	2508 kg (5,529 lb.)
C	At Ground Line	3374 kg (7,438 lb.)	3184 kg (7,019 lb.)
D	Below Ground Line	312 mm (12.3 in.)	312 mm (12.3 in.)
	Rated Capacity of Tines	3900 kg (8,598 lb.)	3900 kg (8,598 lb.)
	Rated Load per SAE J1197		

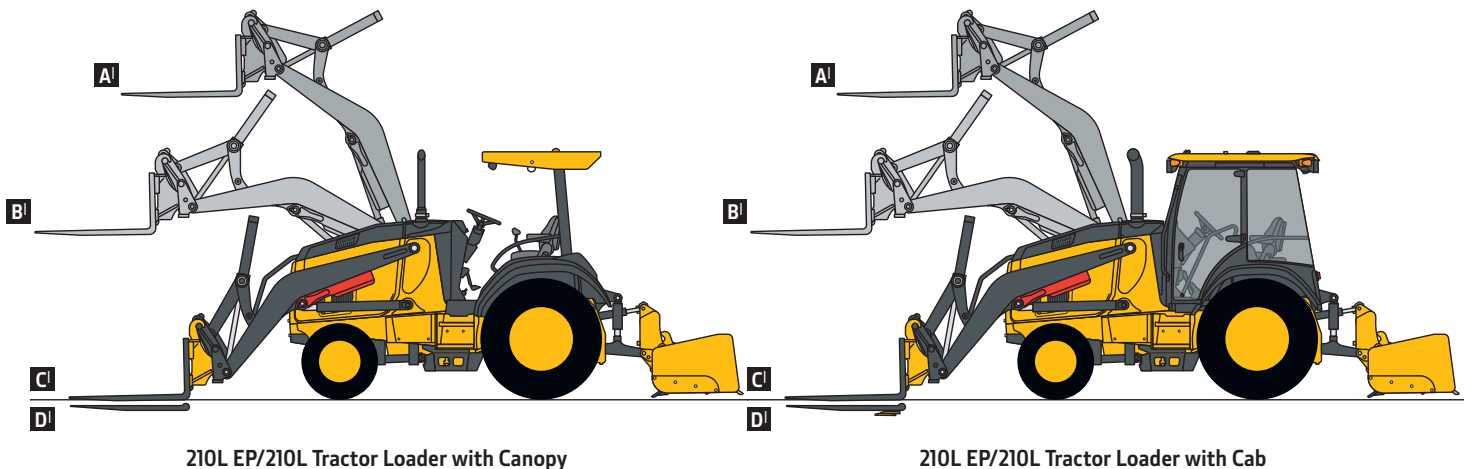

210L EP/210L Tractor Loader with Canopy

210L EP/210L Tractor Loader with Cab

Power Takeoff (PTO) Specs and Performance		210L EP	210L
Type		N/A	Dedicated hydrostatic system (pump, motor, and cooling package) suitable for continuous, heavy-duty PTO operations
	Hydromechanical 540-rpm PTO	N/A	41 kW (55 hp)

Additional equipment

Key: ● Standard ▲ Optional or special

See your John Deere dealer for further information.

210L EP	210L	Engine
●	●	Vertical spin-on engine oil filter
●	●	Vertical spin-on fuel filter with water separator
●		Coolant recovery tank
	●	Coolant recovery tank with low-level indicator
●	●	Serpentine belt with automatic belt tensioner
●	●	Oil-to-water engine oil cooler
●	●	Antifreeze, -37 deg. C (-34 deg. F)
●	●	Dual-element dry-type air cleaner
●	●	Enclosed safety fan guard
●	●	Fold-out, hinged cooling system
	●	Electronically controlled, variable-rate suction-type cooling fan
●		Viscous variable-rate cooling fan
●	●	High ambient temperature engine cooling
●	●	Muffler, under hood with curved-end exhaust stack
	●	Self-cleaning exhaust aftertreatment system
●		Glow plugs
	●	Grid heat
▲	▲	Electric engine coolant heater, 1,000 watts
●	●	Electronic fuel lift pump
Powertrain		
●	●	PowerShift™ transmission: Torque converter with twist-grip Transmission Control Lever (TCL) and neutral safety switch interlock (1st through 4th gears)
●	●	Transmission oil cooler
●	●	Vertical spin-on transmission filter
●	●	Differential lock, electric foot actuated
●	●	Power-assisted hydraulic service brakes (conform to ISO 3450): Inboard, wet multi-disc, self-adjusting and self-equalizing
●	●	Parking/emergency brake with electric switch control (conforms to ISO 3450): Spring applied, hydraulically released wet multi-disc / Independent of service brakes
●	●	Mechanical-front-wheel drive (MFWD), standard differential, sealed axle
▲	▲	MFWD, limited slip, sealed axle
▲	▲	Transmission guard
▲	▲	MFWD driveshaft guard
Category II 3-Point Hitch		
●	●	Integral Category II
●	●	4th-function sectional hydraulic valve, 4th-function auxiliary with capped hoses
▲	▲	5th-function hitch valve with control lever, dual-tilt cylinder
Loader		
●	●	Hydraulic self-leveling
●	●	Return-to-dig feature
●	●	Bucket-level indicator
●	●	Loader boom service lock
▲	▲	Auxiliary loader hydraulics (3rd-function valve) with 2-lever control
▲	▲	Auxiliary loader hydraulics with single control lever with electrohydraulic auxiliary control (MFWD and clutch disconnect)
▲	▲	Tractor built with no loader arms for use in confined areas

210L EP	210L	Loader (continued)
●	●	Palm-on-top loader control; single-button clutch disconnect
▲	▲	Palm-on-top loader control; 3-function fingertip control (clutch disconnect, MFWD, and proportional auxiliary roller)
▲	▲	Ride control
Hydraulic System		
●		104-L/m (27.5 gpm) rated flow
	●	96-L/m (25.3 gpm) rated flow
●	●	Independent hydraulic reservoir
●	●	Independent hydraulic oil cooler
●	●	"O"-ring face-seal connectors
●	●	6-micron vertical spin-on filter
Electrical		
●	●	12-volt system
●	●	130-amp alternator (210L EP canopy or cab; 210L canopy)
	●	150-amp alternator (cab)
●	●	Single battery with 190-min. reserve capacity and 925 CCA
▲	▲	Dual batteries with 380-min. reserve capacity and 1,850 CCA
●	●	Positive terminal battery cover
●	●	Blade-type multi-fused circuits
●	●	By-pass start safety cover on starter
▲	▲	Battery disconnect
Lights		
●	●	For cab and canopy: Front driving/working halogen (2) / Turn signal/flashing lights (2) / Rear stop and taillights (2) / Rear reflectors (2)
▲	▲	Deluxe electrical package for canopy: Front work lights (2), rear work lights (2), 12-volt outlets (2), and battery-disconnect switch
▲	▲	Premium LED lighting package for canopy: Front work lights (2), rear work lights (2), side work lights (2), 12-volt outlets (2), and battery-disconnect switch
Operator's Station		
●	●	Canopy: 2-post, ROPS/FOPS (Level 1 / meets ISO 3471/SAE J1040), steel roof
▲	▲	Cab: ROPS/FOPS (Level 1 / meets ISO 3471/SAE J1040), air conditioning (7.6-kW [26,000 Btu/h] output and CFC-free R-134a refrigerant), headliner, dome light, tinted safety glass, deluxe interior trim, molded floor mats, left cab door, right emergency egress, front windshield wiper, front windshield washer, heater/defroster/pressurizer (11.7-kW [40,000 Btu/h] heater), 12-volt outlets (2), rear working lights (2), and 50-deg. (10 left, 40 right) rotating mechanical-suspension cloth seat
●	●	Electric monitor system with audible and/or visual warning: Service code / Air cleaner restriction / Low alternator voltage / Engine coolant temperature / Engine oil pressure / Hydraulic filter restriction / Park brake on/off / Seat belt / Transmission oil temperature / Hour meter / Engine rpm / System voltage / Job timer / Machine information
●	●	Engine coolant temperature gauge and fuel gauge

210L EP	210L	Operator's Station (continued)
●	●	Left front access
●	●	Slip-resistant steps and ergonomically located handholds
●	●	Built-in Operator's Manual storage compartment with manual
●	●	Interior rearview mirror
●	●	Foot throttle
▲	▲	Hand throttle
●	●	Horn
●	●	Key start switch with electric fuel shutoff
●	●	Suspension vinyl seat, 50-deg. (10 left, 40 right) rotating with flip-up armrests, backrest angle adjustment, swivel base, and 76-mm (3 in.) retractable seat belt
▲	▲	Non-suspension vinyl seat, 50-deg. (10 left, 40 right) rotating with flip-up armrests and 76-mm (3 in.) retractable seat belt
▲	▲	Suspension cloth fabric seat, 50-deg. (10 left, 40 right) rotating with flip-up armrests, backrest angle adjustment, swivel base, and 76-mm (3 in.) retractable seat belt (for use with optional cab)
▲	▲	Enhanced mechanical suspension seat, 70-deg. (20 left, 50 right) rotating with flip-up armrests and tilt steering
Loader Buckets		
●	●	Less bucket, with bucket pins
▲	▲	Less bucket, less pins
▲	▲	General-purpose bucket with cutting edge and skid plates
▲	▲	Heavy-duty bucket
▲	▲	Multipurpose bucket with cutting edge and skid plates
▲	▲	Loader coupler
Box Blade		
▲	▲	2.13-m (84 in.) heavy-duty with hydraulically actuated ripper bar and replaceable router bits
▲	▲	2.20-m (88 in.) heavy-duty with hydraulically actuated ripper bar and replaceable router bits
Overall Vehicle		
●	●	1-piece unitized construction mainframe
●	●	Vehicle tie-downs (2 front and 2 rear)
●	●	Vandal protection for instrument panel, access doors, fuel tank, and hydraulic reservoir
●	●	Reverse warning alarm
▲	▲	Rear-hitch counterweight (318 kg [700 lb.] ¹ and 681 kg [1,500 lb.] ¹)
▲	▲	Wheel weights
	▲	Hydromechanical power takeoff (PTO), 41 kW (55 hp), 540 rpm
▲	▲	3-point hitch weight box
▲	▲	Drawbar, fixed single position
▲	▲	Machine security
▲	▲	Tilt steering
▲	▲	French language kit
▲	▲	Spanish language kit
▲	●	JDLINK™ wireless communication system (available in specific countries; see your dealer for details)

¹Compatible with PTO.

Net engine power is with standard equipment including air cleaner, exhaust system, alternator, and cooling fan at test conditions specified per ISO 9249. No derating is required up to 1500-m (5,000 ft.) altitude for the 210L EP. Specifications and design subject to change without notice. Wherever applicable, specifications are in accordance with SAE and/or ISO standards. Except where otherwise noted, these specifications are based on a unit with 16.9-24 R4 8-ply rear tires, 12-16.5 R4 12-ply front tires, 0.86-m³ (1.12 cu. yd.) loader bucket, full fuel tank, and 79-kg (175 lb.) operator.

