



TRAILER | JEEP  
**S500** | **L40**

# 50-TON FLIP ROLL SCISSORNECK TRAILERS



## INDUSTRY BEST WARRANTY

### 2 YEAR WARRANTY

1 year standard comprehensive and 1 year extended warranty with 5 year structural at no additional cost. *Ask us for details.*

### FLEXIBLE FINANCING

Custom financing solutions available to best suit your business. *Ask us for details.*

## Maximum Payload. Minimum Wear.

The all-new S500 flip-over beavertail scissorneck trailer from Brandt delivers the superior reliability required to handle your heaviest loads and keep coming back for more.

### ① Easier to Own

This trailer is backed by the best support in the business to make ownership stress-free:

- Flexible purchasing options include rentals, rental purchasing, leasing, and conventional financing.
- Brandt's advanced paint protection looks better, lasts longer, and inhibits corrosion for longer trailer life and increased resale value.
- Reliable design and long-lasting components reduce total cost of ownership.

### ② Easier to Operate

The S500's easy-to-use design enables you to do more with less effort:

- Knife-edge gooseneck profile makes it easy to load low ground-clearance vehicles over the front of the trailer.
- Kicker rolls are placed between the first and second axles to reduce friction, making loading and unloading short payloads easier and more efficient.
- Winch and J-hook positioning alternates from side to side, making securing loads easier and more efficient from either side of the trailer.

### ③ Safer

This trailer is purpose-built for safe operation, allowing you to work confidently:

- Premium fir decking throughout provides better traction for the operator in wet and frozen conditions.
- Work lights are placed in important loading and unloading areas, including in the control box, to make operation easier in adverse conditions.
- Remotely-mounted air-tank drain valves make maintenance safer and faster.

Powerful Value. **Delivered.**



# SCISSORNECK TRAILER DIMENSIONS

Shown with optional L40 Jeep  
 \*Belly roll position  
 \*\*Kicker roll position

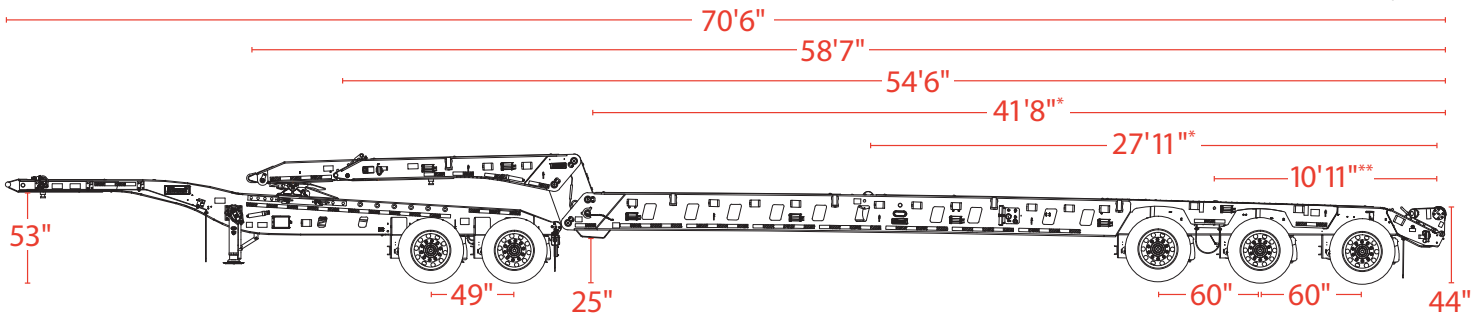

## FEATURES

### Gooseneck Design and Multiple King-Pin Settings

Allows the trailer to utilize tandem- and tri-drive trucks for superior flexibility.

### Fir Decking

Allows easy and inexpensive replacement while minimizing tare weight and maximizing safety.

### Illuminated Control Box

Makes the trailer easier and safer to operate.

### Industry-Exclusive Powder-Coat Finish

Looks better, lasts longer, and inhibits corrosion to increase trailer life and resale value.

RELIABILITY - RATED CAPACITY	
Rated Load on 16' (ton)	50
Nominal Axle Wall Thickness (in)	3/4
DURABILITY - STRUCTURE	
Decking/Floor Material	3" Fir
Paint Finish	Zinc Primer + Polyester Powder Coat
DIMENSIONS	
Deck Length (ft)	41'7"
Overall Length (ft)	54'5"
Wheelbase (ft) - 88" KP	40'7"
Deck Width (ft)	10
Running Gear Width (ft)	10
Loaded Deck Height (in)	45
Upper Coupler Height (in)	53
Gooseneck Swing (in)	80, 112, 160 w/GN ext.

GOOSENECK FEATURES	
Knife Edge Profile	●
Cable Savers	●
2 Pairs of Pin Pockets	●
4 Sets of Winches/J-Hooks	●
3 Pairs of Chain Pockets	●
1/2" Upper Coupler Plate	●
Links to Pin in Step Deck or Hi-Boy Position	●
Gooseneck Extension for Tandem Jeep	○
Swingout Lights	○
DECK FEATURES	
Fold Down Dolly Legs for Unladen Trailer	●
Ratcheting Live Roll in Center of Deck, Comes with 2 Sets of Support Rollers	●
13 Pairs of Chain Pockets	●
8 Pairs of Pin Pockets	●
7 Sets of Winches/J-Hooks	●

SUSPENSION FRAME FEATURES	
Drum Brakes	●
PAN22 Disc Brakes	○
8.25 X 22.5" Aluminum Wheels	●
275/70R22.5 Bridgestone M840 On/Off Road Tires	○
Air Pots Rotated to be in Front of and Above Axle	●
Flip Over Beaver Tail with Grouser Bars	●
8" Flip Tail Roll, Comes with 2 Sets of Support Rollers & Cable Savers	●
Load Bearing Bolsters with Chain Pockets	●
9 Pairs of Pin Pockets	●
3 Pairs of Chain Pockets	●
2 Sets of Winches/J-Hooks	●
Rebound Limiters	●
Strobe Lights	●
Wood Decking in Center	●
Remote Drain Valve Accessible on Outside of Frame	●
Mudflaps	●
Ratcheting Kicker Rolls Between Axles 1 & 2	○
Battery Back-up Kit for Strobes	○
Swingout Lights	○
Work Lights	○

EASY TO OWN - PURCHASE OPTIONS	
Cash	○
Rent or Lease*	○
Low Rate Lease*	○

BUMPER TO BUMPER WARRANTY	
1 Year - Comprehensive	●
2 Year - Comprehensive	○
3 Year - Comprehensive	○

● Included at no extra cost ○ Option available \*See Dealer for Details

For more information  
 Call us at 1-888-227-2638  
 Email us at [sales@brandt.ca](mailto:sales@brandt.ca)  
 Or visit us at [brandt.ca/trailers](http://brandt.ca/trailers)

© Brandt Industries Ltd. All rights reserved. The Brandt name and logo are trademarks of Brandt Industries Ltd., used under license. All product information and specifications are subject to change without notification. Printed in Canada. Revised 09/2024-CU

