



H450

# 45-TON HEAVY HAUL TRAILER



## 2 YEAR WARRANTY

1 year standard comprehensive and 1 year extended warranty with 5 year structural at no additional cost. *Ask us for details.*

## FLEXIBLE FINANCING

Custom financing solutions available to best suit your business. *Ask us for details.*

## Lightweight Heavy-Hauler.

Introducing the all-new H450 commercial hydraulic removable gooseneck tridem trailer from Brandt. This trailer delivers the perfect combination of capacity, durability, and flexibility to suit all of your agricultural and mid-sized construction equipment hauling needs.

### ① Higher Productivity

For enhanced productivity, the H450 delivers versatility and speed to get on the road faster:

- Best-in-class 17" loaded deck height works with more equipment without needing over-height permits.
- 100 ksi steel and tapered I-beam flange deliver a lower tare weight for superior payload capacity.
- Load securement is available everywhere you need it, including the gooseneck, deck, and suspension.

### ② Increased Uptime

High-quality construction and rapid connection points ensure maximum uptime with the H450:

- Innovative gooseneck connects on uneven ground with far greater range for faster turnaround.
- Controls are placed in a sealed box, ensuring longer life of the components and easy operator access.
- Heavy-duty suspension and deck interface are formed instead of welded for maximum durability.

### ③ Lower Cost of Operation

The H450 features long-lasting components and reduced maintenance for a lower cost of ownership.

- Purpose-built hydraulic cylinders from Brandt include protective sleeves for longer cylinder life.
- High-performance wiring harnesses and sealed weatherpack connections dramatically improve longevity.
- Remote air tank drain lines are safer and easier to use, saving time on daily maintenance.

Powerful Value. **Delivered.**



# SPECIFICATIONS H450 TRAILER

## BASE UNIT KEY SPECIFICATIONS

RELIABILITY - RATED CAPACITY		
	H450 Tridem	H450 Tandem+Pin On Connection
Capacity	90,000 lb Fully Distributed (80,000 lb in 16')	
Area of Operation	Canada, US, On Highway	
Use With	R25 Jeep	
Overall Length	46'6" - 54'10"	43'2" - 52'8"
Deck Length	23'11" - 30'3"	24' - 33'
Deck Width	8'6" - 10'	
Running Gear Width	8'6" - 10'	
Wheelbase	39'2" - 46'5"	37'6" - 46'9"
Upper Coupler Height	48" - 50"	
Tractor Swing Clearance	82"	
Gooseneck Extension Swing Clearance	108" (With Optional Gooseneck Extension)	
Loaded Deck Height	17" at 5" Ground Clearance	
Loaded Ground Clearance	Adjustable to 5 settings: 5" to 8"	
Flip Axle Connection Type	Not Available	Flush Top, Pin On - 38" Lug Center, 20" Pin Couple, 1.5" Pin
Gooseneck Type	<ul style="list-style-type: none"> <li>Wide Fully Decked Hydraulic Removable Drop-in Kingpin</li> <li>Low Profile Tapered Beams</li> <li>Easy Detach/Attach on Uneven Ground</li> <li>Truck Wet Kit ISO 7241-B 3/4" Quick Connects</li> <li>Center Drive Lug with Anti-Dive Pin</li> <li>15 gpm, 3000 psi max</li> <li>5 Ground Height Settings</li> <li>Hydraulic Operated T-Style Support Arm</li> <li>Protected Air and Electrical Connections</li> <li>Gooseneck Extension Lugs</li> </ul>	
Gooseneck Top Deck Load Securement	Four Pull-Up D-rings in Corners, Four Alternating 3-Bar Winches	
Deck Type	Flush Deck, 4-Rail, Low Profile Front Ramps With Grouser Bars, Welded Deck End Ramps	
Beams	Fabricated, 100 ksi Flanges and Webs, Cambered to Suit Full Load	
Decking	1 5/16" Apitong	
Decking Load Securement	4 Pull-Up D-rings Between Main Rails, 8 D-rings Per Side Down Outer Rail, 8 Alternating 3-Bar Winches, 7 Chain Cutouts Per Side on Outer Flange, Quantities Change Based on Deck Length	
Storage	Storage Compartment in Base of Gooseneck	
Suspension Frame Type	Fixed Tridem Square Tail	Tandem with Lugs for Flip Axle
Suspension Features	Grouser Bars on Transition Ramps, Dock Bumpers on Lightbar, 2-Sets of Pockets for Oversize/D-Sign	
Primary Suspension Load Securement	4 Flat Mounted D-rings in Corners, 2 Chain Pockets for Cross Chaining	
Additional Suspension Load Securement	3 Alternating 3-Bar Winches, 2 Chain Cutouts on Each Side of Outer Web	2 Alternating 3-Bar Winches, 1 Chain Cutout on Each Side of Outer Web
Suspension Capacity	(3) x HT250 25,000 lb	(2) x HT250 25,000 lb
Axle Capacity (Nominal)	22,500 lb Per Axle, 5/8 Wall	
Hubs	Duralite, 75W90 Synthetic Gear Oil, 10-Stud	Duralite, 75W90 Synthetic Gear Oil, 10-Stud



**RELIABILITY - RATED CAPACITY CONT'D**

	H450 Tridem	H450 Tandem+Pin On Connection
<b>Air System</b>	<ul style="list-style-type: none"> <li>• FMVSS</li> <li>• CMVSS Compliant</li> <li>• 2S2M ABS System</li> </ul>	<ul style="list-style-type: none"> <li>• Weather Sealed</li> <li>• Bolster Mounted Air Control Box including Air Gauge</li> <li>• Regulated Air Override</li> <li>• 5-Position Ride Height Selection</li> <li>• Dump Valve and Spring Brake Release Valve</li> </ul>
<b>Electrical System</b>	FMVSS, CMVSS Compliant, LED Lighting, 4" Lightbar Mounted Strobes with Switch in Control Box, OEM Harness with Weatherproof Connectors and Braided Loom, Rear 7-way Socket for Auxiliary Lighting	

**AXLE SPACING**

49"	○	○
54"	○	○
60"	○	○

**GOOSENECK OPTIONS**

<b>Standard</b>	82" Swing Gooseneck, Frame Length 9'10", Fully Decked, Deck 8'6" Wide by 7'9" Long
<b>Narrow</b>	82" Swing Gooseneck, Frame Length 9'10", Narrow Frame, No Decking

**OUTRIGGERS**

<b>No Outriggers</b>	○
<b>Steel Swing-out Outriggers</b>	Steel Swing-out Outriggers, 10'6" Wide on 8'6" Trailer, Every 2', Double at Front
<b>Aluminum Pull-out Outriggers</b>	Aluminum Pull-out Outriggers with Traction Grip, 13' Wide on 8'6" Trailer, 15' Wide on 10'0" Trailer, 16" Beam Centers

**INNER SUSPENSION OPTIONS**

<b>Full Wood Deck</b>	1 5/16 Apitong Full Width, Mini Boom Trough Plate
<b>Full Suspension Boom Trough</b>	1 5/16 Apitong Over Tires, Full Length Deep Boom Trough

**DECK LENGTH OPTIONS**

<b>8'- 6" Wide, Fully Decked</b>	23'11"	24'0"
	25'11"	26'0"
	27'11"	28'0"
	28'5"	28'3"
	28'11"	29'0"
	29'5"	29'3"
	29'11"	30'0"
	30'3"	32'6"
<b>10'- 0" Wide, Fully Decked</b>	28'5"	28'3"
	28'11"	29'3"
	30'3"	32'6"
		33'0"
		33'0"

# HEAVY HAUL TRAILER DIMENSIONS

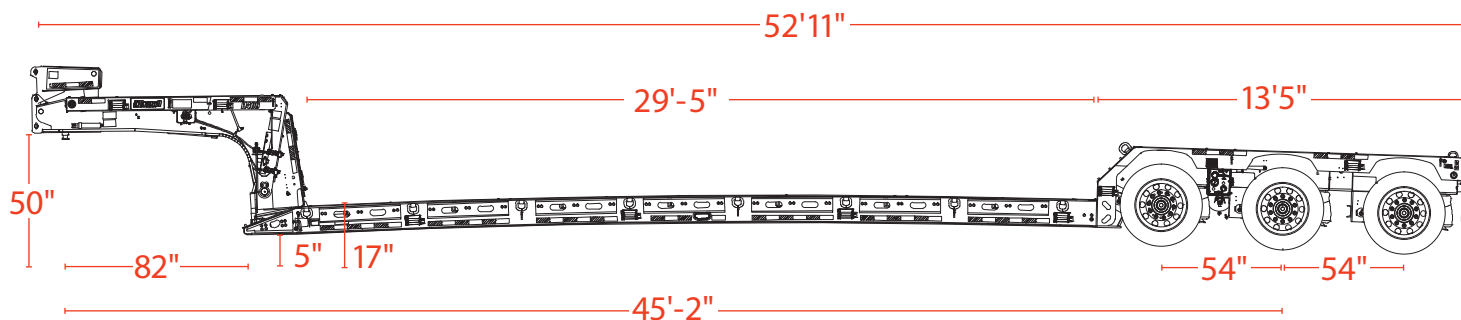

## FEATURES

### Adjustable Rear Ride Height

Choose from five settings in 1.5" increments for precise ground clearance from 5" to 8".

### Narrow, Tapered Gooseneck

Delivers best-in-class deck well length to haul larger, longer equipment.

### Gooseneck Extension

Narrow gooseneck extension accommodates Brandt R25 single axle jeep, tridem truck tractor, or tandem with pusher axle to transfer weight and increase payload.

### T-Style Gooseneck Support Arm

Keeps the neck stable on uneven terrain, allowing the weight to rest on the truck or jeep frame when disconnected.

### Support Arm T-Bar End Caps

Deliver easier reconnection by supporting the unit on uneven terrain while preventing damage and ensuring operator safety.

### Gooseneck Work Lights

Optional lights on the rear of the gooseneck provide a safer deck workspace for operators in low light conditions.

### Excellent Connection Points

Recessed D-rings and large chain cut outs make it easier and faster to secure your load and hit the road.

### Apitong Decking

High-quality hardwood decking lasts longer than pressure-treated options, and provides a safe working space for operators.

### Durable Finish

Brandt's superior powder-coat paint process provides a lasting finish for rust protection and long-term resale value.

### Superior Brake Performance

For rapid response time and reduced stopping distance, the tractor brake signal is boosted for superior brake application and release.

### 14 HP EFI Hydraulic Power Pack

Optional power pack features fuel injection for better performance in all conditions, and is enclosed to prevent damage from the elements.

For more information  
Call us at 1-888-227-2638  
Email us at [sales@brandt.ca](mailto:sales@brandt.ca)  
Or visit us at [brandt.ca/trailers](http://brandt.ca/trailers)

© Brandt Industries Ltd. All rights reserved. The Brandt name and logo are trademarks of Brandt Industries Ltd., used under license. All product information and specifications are subject to change without notification. Printed in Canada. Revised 09/2024-CU

**Brandt**