

SWING MACHINES

3154G / 3156G / 3754G / 3756G



JOHN DEERE



PRODUCTIVITY IN
FULL SWING



STACK THE DECK.



Five years in the making. Backed by over a half-century of experience in the woods. To build a better swing machine, we went to you, our customer. Through our Customer Advocate Group (CAG), we collected invaluable input from loggers just like you — the ones who live it every day. Then we spent thousands of hours testing the machines until we got them exactly right.

You spoke. We listened. We responded with a major cab update that sets a new standard for comfort and safety — improvements that you won't be able to imagine living without. And as always, there are a host of other new features that help boost productivity and maximize uptime, while lowering daily operating costs. Our Swing Machines will change your expectations about what a swing machine can accomplish.



The new cooling package design is tougher and keeps the hydraulics cooler. And with fewer components, the electrical system is more reliable and easier to troubleshoot.

James Faulk, CAG member
Hill Logging Inc., Jeffersonville, Georgia



RUGGED, RELIABLE, AND READY TO RUMBLE

Dishes it out. And takes it.

You never quit, and neither will your G-Series Swing Machine. Because in the forest, uptime isn't everything. It's the only thing.

Simplified electrical system

More reliable electrical architecture simplifies wiring harnesses and minimizes the number of fuses and relays needed, eliminating 30 percent of the electrical connectors. JDLink™ enables quick fault detection and troubleshooting.

Beefier structures

Undercarriage and mainframe are designed to deliver up to 67-percent longer life. More robust boom-foot base with larger pins on the 3154G and 3156G strengthens the boom connection. Bushings have been added to the boom tower and boom tip to improve joint integrity and simplify repair.

More robust cooling system

Larger, higher-capacity coolers and improved airflow help reduce hydraulic operating temperature, for maximum component life. Bar-and-plate design is more durable than in-style coolers.

Hydraulic reversing fan

Variable-speed fan runs only as fast and often as conditions demand, conserving power and fuel. Reversing fan automatically shifts airflow to eject cooler-core debris. For more frequent cleaning, simply press the handy dash-mounted button to activate the reversing cycle.



67%

MORE DURABLE
FRAME STRUCTURE



25%
**MORE
SPACE**
on Side-Entry Cab



Improved visibility

Countless hours of virtual-reality studies and field-testing with loggers led to superb all-around visibility. On the log-loader rear-entry cab, floor-mounted windows and cab-forward riser option improve visibility to the tracks and working area in log-loading applications. Polycarbonate windows durably meet safety requirements.

Easy-to-read monitor

Multi-language color LCD monitor provides intuitive access to a wealth of machine data and functions.

Safer access

Log-loader rear-entry cab helps ensure safer, easier entry and exit.

FORWARD-THINKING CAB DESIGN

Truly visionary.

Designed by loggers for loggers, two cab options provide significantly more operator comfort. Forestry-excavator cab is 25-percent larger than previous models. Log-loader cab features a riser and windows in the floor, for superb visibility to the tracks and work area. Optional cab-forward riser enables additional visibility to the right. Other fatigue-beating creature comforts include efficient climate control, heated/cooled seats, ergonomic controls, and XM Satellite Radio™-ready system.

The cab is a big step forward, with more comfort and better visibility. It's really come a long way. When you can reduce fatigue over a long shift, your operators will be more productive. And they'll want to come back tomorrow.

Brent Parries, CAG member

Pacific Forest Contractors Inc., Mount Hood, Oregon



Spacious, more comfortable cab

Spacious cab boasts an additional three in. of legroom. It's isolation mounted to reduce noise and vibration while smoothing the ride in rough terrain, substantially reducing fatigue.

Effortless control

Ergonomically correct short-throw pilot levers provide smooth, precise fingertip control with less movement or effort.



17%

MORE LIFTING POWER WITH
LONGER TRACK FRAMES



MOVE MORE WOOD

Put productivity into full swing.

Whether you need a log loader, shovel logger, road builder, or processor/harvester, G-Series Swing Machines will help you get more done, more efficiently. Choose a 3154G/3754G Forestry Excavator or 3156G/3756G Crawler Log Loader/Processor to match your application.

More stable and able

Longer track frames on the 3754G and 3756G put more track on the ground, for more stability — and up to 17-percent more lifting power.

Ample illumination

Five high-intensity halogen lights are standard for when you need to extend your workday beyond daylight. Optional 14-light LED package plus service and access lights provide outstanding all-around illumination.

Improved performance

Powerful 9L diesel engine on the 3154G and 3156G delivers 30-percent more horsepower at low rpm. Next-size-up main hydraulic pump improves multifunctioning, fuel economy, and component durability.

Fully integrated processing heads

Reliable, productive Waratah heads come factory installed and ready to go. Through-nose plumbing option routes hoses up and out of harm's way to extend hose life, increasing uptime and reducing operating costs.



A large John Deere harvester head is shown in the process of lifting a massive log. The harvester's mechanical arm is dark and complex, with a large, curved blade-like structure. The log is thick and has a rough, weathered surface with some orange-brown staining. The background is a dense forest of tall, thin evergreen trees under a clear blue sky. In the distance, snow-capped mountains are visible.

**ULTIMATE UPTIME, JOHN DEERE
FORESTSIGHT,[™] JDLINK**

Maximize machine uptime. Optimize your operation.

As a logger, you demand more uptime. Fast, accurate diagnosis of machine problems. Rapid, effective service response and the right part, the first time. And closer tracking of machines and operators for efficient operation. John Deere forestry technology solutions are there to help you — wherever the woods take you.

Get valuable insight with

JOHN DEERE FORESTSIGHT

With a JDLink subscription, alerts can be sent to your computer or mobile device — or your dealer, if you choose — to inform you of immediate machine issues. If downtime does occur, exclusive remote diagnostics and programming enable your Deere dealer to minimize the time and cost associated with sending a technician to the logging site for an initial diagnostic visit. You can also receive reminders of periodic scheduled maintenance on your computer or mobile device, or from your dealer.

Keep downtime down with

ULTIMATE UPTIME

In addition to the base John Deere ForestSight features, our dealers work with you to build an uptime package that meets your specific needs, including customized maintenance and repair agreements, onsite parts availability, extended warranties, fluid sampling, response-time guarantees, and more.



“The performance is just really, really good. I’ve always liked the stability of Deere swing machines. And with the larger undercarriages, these machines are even more stable.”

Roger Smith, CAG member

RL Smith Logging, Olympia, Washington

SIMPLE TO SERVICE.

See the light

With the LED light option, illumination in all service compartments means you won't have to fumble around for a flashlight before dawn or after dark.

Wide-open access

Larger service bays make it easier to access components, helping ensure daily checks and preventative maintenance get done effortlessly and on schedule.

Tilt-down panel

Right-side service panel tilts down to provide a stable platform for accessing daily and periodic-maintenance items. It also provides fast, convenient access to filters, diesel exhaust fluid (DEF), hydraulic oil-fill locations, and other common service points.

Remote diagnostics

When equipped with JDLink, fast, accurate remote diagnostics and rapid service response with the right part the first time, industry-leading parts availability, and dealer support are always within easy reach.

Impressive fuel economy

Three productivity modes allow you to adjust the machine to the application. **High productivity** delivers more power and faster hydraulic response. **Power** delivers a balance of power, speed, and fuel economy for normal operation. **Economy** limits top speed and helps save fuel.





3154G

Engine		3154G Road Builder	Optional engine for use in Canada, Australia, and New Zealand
		Base engine for use in U.S. and U.S. Territories	
Manufacturer and Model		John Deere PowerTech™ PSS 9.0 L	John Deere PowerTech™ Plus 9.0 L
Non-Road Emission Standards		EPA Final Tier 4/EU Stage IV	EPA Tier 3/EU Stage IIIA
Net Rated Power (ISO 9249)		186 kW (249 hp) at 1,900 rpm	186 kW (249 hp) at 1,900 rpm
Cylinders		6	6
Engine Displacement		9.0 L (549 cu. in.)	9.0 L (549 cu. in.)
Off-Level Capacity		70% (35 deg.)	70% (35 deg.)
Aspiration		Series turbocharged, air-to-air charge-air cooler	Turbocharged, air-to-air charge-air cooler
Oil Filter, Remote Mounted		Full-flow spin-on filter	Full-flow spin-on filter
Cooling			
Fan Drive		Cool-on-demand hydraulic-driven, suction-type fan remote-mounted drive w/ optional reversing fan	
Powertrain			
2-speed propel with automatic shift			
Maximum Travel Speed			
Low		2.7 km/h (1.7 mph)	
High		4.2 km/h (2.6 mph)	
Drawbar Pull		30 350 kgf (66,910 lbf)	
Hydraulics			
Open center, pilot operated			
Main Pumps			
		2 variable-displacement pumps	
Maximum Rated Flow x 2		236 L/m (62.3 gpm)	
System Operating Pressure			
Implement Circuits		34 300 kPa (4,975 psi)	
Power Boost		38 000 kPa (5,511 psi)	
Controls		Pilot levers; short-stroke, low-effort hydraulic pilot with shutoff lever	
Electrical			
		<i>EPA Final Tier 4/EU Stage IV</i>	<i>EPA Tier 3/EU Stage IIIA</i>
System Voltage		24 volt	24 volt
Alternator Rating		150 amp	130 amp
Lights			
Work		5 halogen: 3 cab front and 2 right-hand front log deflector standard / 14 LEDs optional	
Access (optional)		1 LED (rear right cab)	1 LED (rear right cab)
Service		5 LEDs (compartment and engine hood)	5 LEDs (compartment and engine hood)
Undercarriage			
Rollers (per side)			
Carrier		2	
Track		9	
Shoes, Double Grousers (per side)		48	
Undercarriage Pitch		216 mm (8.5 in.)	



Ground Pressure	3154G Road Builder	
700-mm (28 in.) Double-Grouser Shoes	2.69-m (8 ft. 10 in.) Undercarriage	2.92-m (9 ft. 7 in.) Undercarriage
	65.6 kPa (9.5 psi)	65.8 kPa (9.5 psi)

Swing Mechanism		
Swing Speed	8.7 rpm	
Swing Torque	120 000 Nm (88,507 lb.-ft.)	

Operator's Station		
Operator Height from Ground (eye level), Side-Entry Forestry Cab	3125 mm (10 ft. 3 in.)	

Serviceability

Refill Capacities		
Fuel Tank	1080.0 L (285.0 gal.)	
Cooling System	39.7 L (10.5 gal.)	
Diesel Exhaust Fluid (DEF) Tank (FT4)	43.6 L (11.5 gal.)	
Engine Crankcase (including filter)	27.0 L (28.5 qt.)	
Hydraulic Tank Oil	195.0 L (52.0 gal.)	

Operating Weights
 With full fuel tank, 79-kg (175 lb.) operator, side-entry forestry cab, 5538-kg (12,206 lb.) counterweight, 700-mm (28 in.) double-grouser shoes, FT4 engine, and 2.69-m (8 ft. 10 in.) undercarriage; no attachment included

SAE Operating Weight	EPA Final Tier 4/EU Stage IV	EPA Tier 3/EU Stage IIIA
	37 174 kg (81,954 lb.)	36 947 kg (81,454 lb.)

Optional Components (add weight)		
Rear-Entry Cab	671 kg (1,480 lb.)	671 kg (1,480 lb.)
Cab Forward	739 kg (1,630 lb.)	739 kg (1,630 lb.)
2.92-m (9 ft. 7 in.) Undercarriage	678 kg (1,494 lb.)	678 kg (1,494 lb.)

Operating Dimensions

With 700-mm (28 in.) shoes; 5538-kg (12,206 lb.) counterweight; 3.1-m (10 ft. 2 in.) arm; 1034-kg (2,279 lb.), 1.34-m³ (1.75 cu. yd.), 1065-mm (42 in.) bucket; full fuel tank; 79-kg (175 lb.) operator, and standard equipment

A Maximum Reach	10.80 m (35 ft. 5 in.)
A' Maximum Reach at Ground Level	10.54 m (34 ft. 7 in.)
B Maximum Digging Depth	5.99 m (19 ft. 8 in.)
C Maximum Cutting Height	11.86 m (38 ft. 11 in.)
D Maximum Dumping Height	8.79 m (28 ft. 10 in.)
E Minimum Swing Radius	2.69 m (8 ft. 10 in.)
F Tail Swing Radius	3.68 m (12 ft. 1 in.)

3154G Road Builder

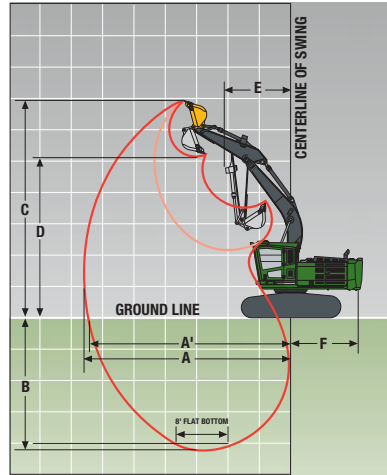

Machine not exactly as shown. Illustrations for dimensioning purposes only.

3154G

Machine Dimensions	3154G Road Builder	
	2.69-m (8 ft. 10 in.) Undercarriage	2.92-m (9 ft. 7 in.) Undercarriage
A Height (side-entry cab)	3.84 m (12 ft. 7 in.)	3.86 m (12 ft. 8 in.)
B Overall Length	11.15 m (36 ft. 7 in.)	11.15 m (36 ft. 7 in.)
C Rear-End Length / Swing Radius	3.61 m (11 ft. 10 in.)	3.61 m (11 ft. 10 in.)
D Distance Between Idler / Sprocket Centerline	4.06 m (13 ft. 4 in.)	4.06 m (13 ft. 4 in.)
E Undercarriage Length	5.00 m (16 ft. 5 in.)	5.00 m (16 ft. 5 in.)
F Counterweight Clearance	1.47 m (4 ft. 10 in.)	1.50 m (4 ft. 11 in.)
G Upperstructure Width	3.48 m (11 ft. 5 in.)	3.48 m (11 ft. 5 in.)
H Cab Height (side-entry cab)	3.84 m (12 ft. 7 in.)	3.86 m (12 ft. 8 in.)
I Track Width with 700-mm (28 in.) Double-Grouser Shoes	0.71 m (28 in.)	0.71 m (28 in.)
J Center of Sprocket to Center of Sprocket	2.69 m (8 ft. 10 in.)	2.92 m (9 ft. 7 in.)
K Ground Clearance	0.76 m (30 in.)	0.79 m (31 in.)
L Undercarriage Width with 700-mm (28 in.) Double-Grouser Shoes	3.40 m (11 ft. 2 in.)	3.63 m (11 ft. 11 in.)

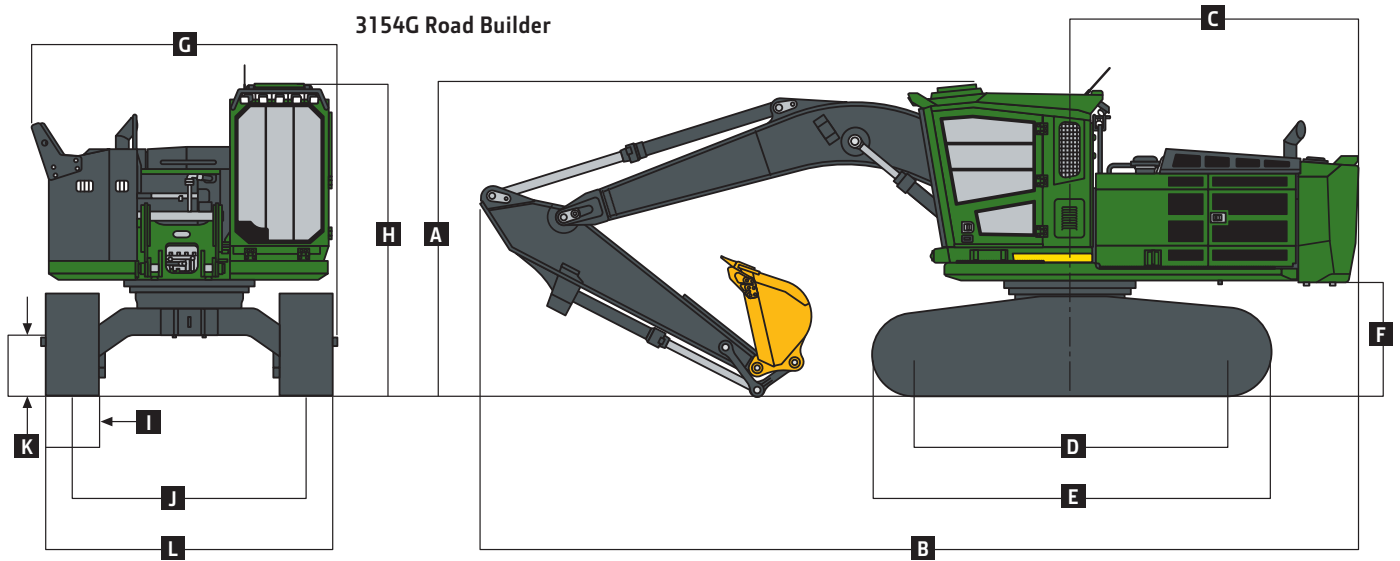

Attachment weight is not included when calculating the lift capacities.

Boldface type indicates hydraulic-limited capacities with power boost; **lightface** type indicates stability-limited capacities, in kg (lb.).
 Figures do not exceed 87 percent of hydraulic capacities or 75 percent of weight needed to tip machine.

Lift Capacity — 3154G Road Builder with 2.69-m (8 ft. 10 in.) undercarriage and 700-mm (28 in.) shoes; bare pin										
Load Point Height	3.1 m (10 ft.)		4.6 m (15 ft.)		6.1 m (20 ft.)		7.6 m (25 ft.)		9.1 m (30 ft.)	
	Over Front	Over Side	Over Front	Over Side	Over Front	Over Side	Over Front	Over Side	Over Front	Over Side
7.6 m (25 ft.)					6930	6930				
					(15,260)	(15,260)				
6.1 m (20 ft.)			8280	8280	7350	7350	6850	6850		
			(18,250)	(18,250)	(16,200)	(16,200)	(15,090)	(15,090)		
4.6 m (15 ft.)	15 500	15 500	10 320	10 320	8280	8280	7230	7230		
	(34,150)	(34,150)	(22,740)	(22,740)	(18,240)	(18,240)	(15,940)	(15,940)		
3.1 m (10 ft.)			12 760	12 760	9410	9410	7780	7780	6860	5980
			(28,110)	(28,110)	(20,740)	(20,740)	(17,140)	(17,140)	(15,120)	(13,190)
1.5 m (5 ft.)			14 410	14 410	10 360	10 260	8270	7560	6990	5890
			(31,760)	(31,760)	(22,830)	(22,600)	(18,230)	(16,670)	(15,410)	(12,980)
Ground Line	21 140	21 140	14 790	14 790	10 810	10 000	8510	7410		
	(46,600)	(46,600)	(32,600)	(32,600)	(23,830)	(22,040)	(18,750)	(16,340)		
-1.5 m (-5 ft.)	19 670	19 670	14 180	14 180	10 620	9910	8260	7370		
	(43,360)	(43,360)	(31,260)	(31,260)	(23,410)	(21,850)	(18,210)	(16,240)		
-3.1 m (-10 ft.)	16 960	16 960	12 610	12 610	9570	9570				
	(37,370)	(37,370)	(27,800)	(27,800)	(21,090)	(21,090)				
Lift Capacity — 3154G Road Builder with 2.92-m (9 ft. 7 in.) undercarriage and 700-mm (28 in.) shoes; bare pin										
Load Point Height	3.1 m (10 ft.)		4.6 m (15 ft.)		6.1 m (20 ft.)		7.6 m (25 ft.)		9.1 m (30 ft.)	
	Over Front	Over Side	Over Front	Over Side	Over Front	Over Side	Over Front	Over Side	Over Front	Over Side
7.6 m (25 ft.)					6930	6930				
					(15,260)	(15,260)				
6.1 m (20 ft.)			8280	8280	7350	7350	6850	6850		
			(18,250)	(18,250)	(16,200)	(16,200)	(15,090)	(15,090)		
4.6 m (15 ft.)	15 500	15 500	10 320	10 320	8280	8280	7230	7230		
	(34,150)	(34,150)	(22,740)	(22,740)	(18,240)	(18,240)	(15,940)	(15,940)		
3.1 m (10 ft.)			12 760	12 760	9410	9410	7780	7780	6860	6510
			(28,110)	(28,110)	(20,740)	(20,740)	(17,140)	(17,140)	(15,120)	(14,350)
1.5 m (5 ft.)			14 410	14 410	10 360	10 360	8270	8250	6990	6420
			(31,760)	(31,760)	(22,830)	(22,830)	(18,230)	(18,190)	(15,410)	(14,140)
Ground Line	21 140	21 140	14 790	14 790	10 810	10 810	8510	8100		
	(46,600)	(46,600)	(32,600)	(32,600)	(23,830)	(23,830)	(18,750)	(17,850)		
-1.5 m (-5 ft.)	19 670	19 670	14 180	14 180	10 620	10 620	8260	8050		
	(43,360)	(43,360)	(31,260)	(31,260)	(23,410)	(23,410)	(18,210)	(17,750)		
-3.1 m (-10 ft.)	16 960	16 960	12 610	12 610	9570	9570				
	(37,370)	(37,370)	(27,800)	(27,800)	(21,090)	(21,090)				

3156G

Engine	3156G Processor / Valve-in-Head (VIH) Log Loader / Live-Heel Log Loader		
	Base engine for use in U.S. and U.S. Territories	Optional engine for use in Canada, Australia, and New Zealand	
Manufacturer and Model	John Deere PowerTech™ PSS 9.0 L	John Deere PowerTech™ Plus 9.0 L	
Non-Road Emission Standards	EPA Final Tier 4/EU Stage IV	EPA Tier 3/EU Stage IIIA	
Net Rated Power (ISO 9249)	186 kW (249 hp) at 1,900 rpm	186 kW (249 hp) at 1,900 rpm	
Cylinders	6	6	
Engine Displacement	9.0 L (549 cu. in.)	9.0 L (549 cu. in.)	
Off-Level Capacity	70% (35 deg.)	70% (35 deg.)	
Aspiration	Series turbocharged, air-to-air charge-air cooler	Turbocharged, air-to-air charge-air cooler	
Oil Filter, Remote Mounted	Full-flow spin-on filter	Full-flow spin-on filter	
Cooling			
Fan Drive	Cool-on-demand hydraulic-driven, suction-type fan remote-mounted drive w/ optional reversing fan		
Powertrain			
2-speed propel with automatic shift			
Maximum Travel Speed			
Low	2.7 km/h (1.7 mph)		
High	4.2 km/h (2.6 mph)		
Drawbar Pull	30 350 kgf (66,910 lbf)		
Hydraulics			
Open center, pilot operated			
Main Pumps			
2 variable-displacement pumps			
Maximum Rated Flow x 2	236 L/m (62.3 gpm)		
System Operating Pressure			
Implement Circuits	34 300 kPa (4,975 psi)		
Power Boost	38 000 kPa (5,511 psi)		
Controls	Pilot levers; short-stroke, low-effort hydraulic pilot with shutoff lever		
Electrical			
	EPA Final Tier 4/EU Stage IV	EPA Tier 3/EU Stage IIIA	
System Voltage	24 volt		
Alternator Rating	150 amp		
Lights			
Work	5 halogen: 3 cab front and 2 right-hand front log deflector standard / 14 LEDs optional		
Access (optional)	1 LED (rear right cab)		
Service	5 LEDs (compartment and engine hood)		
Undercarriage			
Rollers (per side)			
Carrier	2		
Track	9		
Shoes, Double Grousers (per side)	48		
Undercarriage Pitch	216 mm (8.5 in.)		
Ground Pressure			
	3156G Processor	3156G VIH Log Loader	3156G Live-Heel Log Loader
Undercarriage	2.92-m (9 ft. 7 in.)		
700-mm (28 in.) Double-Grouser Shoes	74.9 kPa (10.9 psi)		
		72.4 kPa (10.5 psi)	72.2 kPa (10.5 psi)
Swing Mechanism			
3156G Processor / VIH Log Loader / Live-Heel Log Loader			
Swing Speed	8.7 rpm		
Swing Torque	120 000 Nm (88,507 lb.-ft.)		



Operator's Station 3156G Processor / VIH Log Loader / Live-Heel Log Loader

Operator Height from Ground (eye level)	
Side-Entry Forestry Cab	3125 mm (10 ft. 3 in.)
Rear-Entry Log Loader Cab	4471 mm (14 ft. 8 in.)

Serviceability

Refill Capacities	
Fuel Tank	1080.0 L (285.0 gal.)
Cooling System	39.7 L (10.5 gal.)
Diesel Exhaust Fluid (DEF) Tank (FT4)	43.6 L (11.5 gal.)
Engine Crankcase (including filter)	27.0 L (28.5 qt.)
Hydraulic Tank Oil	195.0 L (52.0 gal.)

Operating Weights 3156G Processor 3156G VIH Log Loader 3156G Live-Heel Log Loader

With full fuel tank, 79-kg (175 lb.) operator, rear-entry forestry cab, 6558-kg (14,454 lb.) counterweight, 700-mm (28 in.) double-grouser shoes, FT4 engine, and 2.92-m (9 ft. 7 in.) undercarriage; no attachment included

	EPA Final Tier 4/ EU Stage IV	EPA Tier 3/ EU Stage IIIA	EPA Final Tier 4/ EU Stage IV	EPA Tier 3/ EU Stage IIIA	EPA Final Tier 4/ EU Stage IV	EPA Tier 3/ EU Stage IIIA
SAE Operating Weight	42 579 kg (93,870 lb.)	42 352 kg (93,370 lb.)	42 352 kg (93,371 lb.)	42 126 kg (92,871 lb.)	43 429 kg (95,745 lb.)	43 202 kg (95,245 lb.)

Optional Components (add weight)

Side-Entry Cab	-671 kg (-1,480 lb.)	-671 kg (-1,480 lb.)	-671 kg (-1,480 lb.)	-671 kg (-1,480 lb.)	-671 kg (-1,480 lb.)	-671 kg (-1,480 lb.)
Rear-Entry Cab – Cab Forward	68 kg (150 lb.)	68 kg (150 lb.)	68 kg (150 lb.)	68 kg (150 lb.)	68 kg (150 lb.)	68 kg (150 lb.)

Operating Dimensions

With 700-mm (28 in.) shoes; 6558-kg (14,454 lb.) counterweight; full fuel tank; 79-kg (175 lb.) operator, and standard equipment

	Processor Arm 4.56-m (14 ft. 11 in.)	VIH Log Loader Arm 4.56-m (14 ft. 11 in.)	Live-Heel Log Loader Arm 4.56-m (14 ft. 11 in.)
A Maximum Reach	11.07 m (36 ft. 4 in.)	11.13 m (36 ft. 6 in.)	12.55 m (41 ft. 2 in.)
A' Maximum Reach at Ground Level	10.82 m (35 ft. 6 in.)	10.90 m (35 ft. 9 in.)	12.34 m (40 ft. 6 in.)
B Maximum Working Depth	3.05 m (10 ft. 0 in.)	3.02 m (9 ft. 11 in.)	4.45 m (14 ft. 7 in.)
C Maximum Working Height	13.00 m (42 ft. 8 in.)	13.13 m (43 ft. 1 in.)	14.53 m (47 ft. 8 in.)
D Maximum Log-Level Height	10.06 m (33 ft. 0 in.)	8.97 m (29 ft. 5 in.)*	9.25 m (30 ft. 4 in.)
E Minimum Swing Radius	4.57 m (15 ft. 0 in.)	5.03 m (16 ft. 6 in.)	4.57 m (15 ft. 0 in.)
F Tail Swing Radius	3.71 m (12 ft. 2 in.)	3.71 m (12 ft. 2 in.)	3.71 m (12 ft. 2 in.)

*Attachment dependent.

3156G Processor

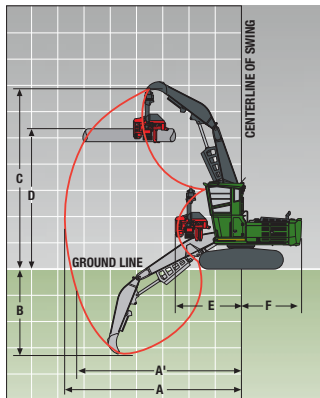

3156G VIH

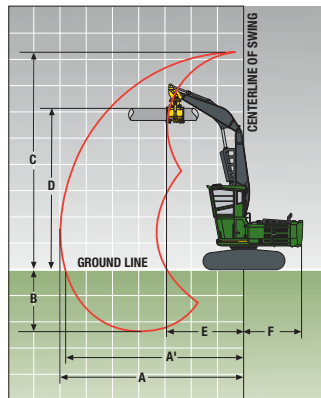

3156G Live Heel

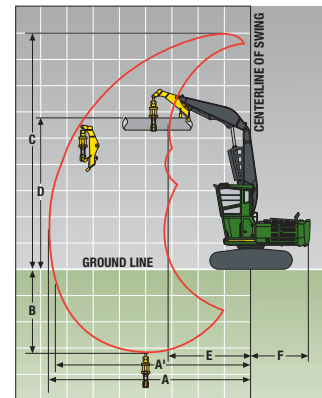

3156G

Machine Dimensions	3156G Processor	3156G VIH Log Loader	3156G Live-Heel Log Loader
A Height (rear-entry cab)	3.71 m (12 ft. 2 in.)	3.71 m (12 ft. 2 in.)	3.71 m (12 ft. 2 in.)
B Overall Length	14.81 m (48 ft. 7 in.)	15.39 m (50 ft. 6 in.)	15.52 m (50 ft. 11 in.)
C Rear-End Length / Swing Radius	3.63 m (11 ft. 11 in.)	3.63 m (11 ft. 11 in.)	3.63 m (11 ft. 11 in.)
D Distance Between Idler / Sprocket Centerline	4.06 m (13 ft. 4 in.)	4.06 m (13 ft. 4 in.)	4.06 m (13 ft. 4 in.)
E Undercarriage Length	5.00 m (16 ft. 5 in.)	5.00 m (16 ft. 5 in.)	5.00 m (16 ft. 5 in.)
F Counterweight Clearance	1.50 m (4 ft. 11 in.)	1.50 m (4 ft. 11 in.)	1.50 m (4 ft. 11 in.)
G Upperstructure Width	3.48 m (11 ft. 5 in.)	3.48 m (11 ft. 5 in.)	3.48 m (11 ft. 5 in.)
H Cab Height (rear-entry cab)	5.21 m (17 ft. 1 in.)	5.21 m (17 ft. 1 in.)	5.21 m (17 ft. 1 in.)
H ^I Tilted Cab Height (rear-entry cab)	3.71 m (12 ft. 2 in.)	3.71 m (12 ft. 2 in.)	3.71 m (12 ft. 2 in.)
I Track Width with 700-mm (28 in.) Double-Grouser Shoes	0.71 m (28 in.)	0.71 m (28 in.)	0.71 m (28 in.)
J Center of Sprocket to Center of Sprocket	2.92 m (9 ft. 7 in.)	2.92 m (9 ft. 7 in.)	2.92 m (9 ft. 7 in.)
K Ground Clearance	0.79 m (31 in.)	0.79 m (31 in.)	0.79 m (31 in.)
L Undercarriage Width with 700-mm (28 in.) Double-Grouser Shoes	3.63 m (11 ft. 11 in.)	3.63 m (11 ft. 11 in.)	3.63 m (11 ft. 11 in.)

3156G Processor – Low Cab

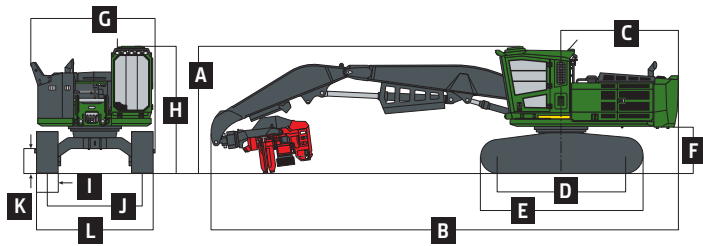

3156G Processor – High Cab

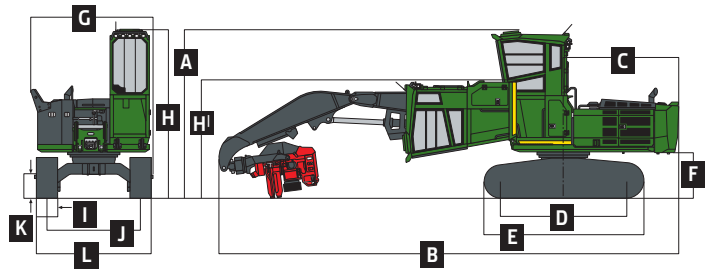

3156G VIH

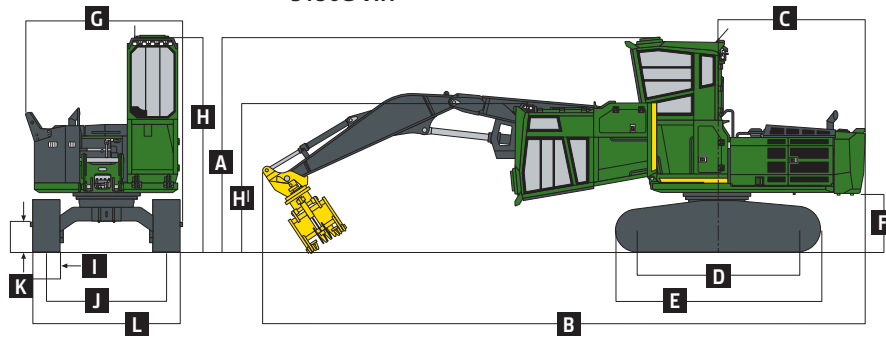

3156G Live Heel

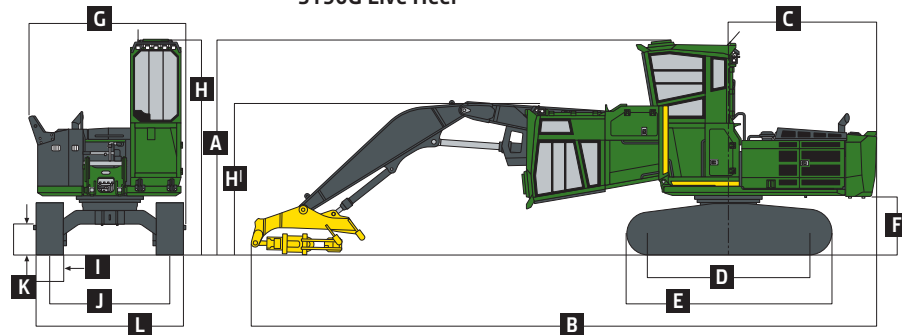

Specifications are subject to change without notice.

Machine not exactly as shown. Illustrations for dimensioning purposes only.

Attachment weight is not included when calculating the lift capacities. Boldface type indicates hydraulic-limited capacities with power boost; lightface type indicates stability-limited capacities, in kg (lb.). Figures do not exceed 87 percent of hydraulic capacities or 75 percent of weight needed to tip machine.

3156G

Lift Capacity — 3156G Processor with 2.92-m (9 ft. 7 in.) undercarriage and 700-mm (28 in.) shoes; bare pin

Load Point Height	4.6 m (15 ft.)		6.1 m (20 ft.)		7.6 m (25 ft.)		9.1 m (30 ft.)		10.7 m (35 ft.)		
	Over Front	Over Side	Over Front	Over Side	Over Front	Over Side	Over Front	Over Side	Over Front	Over Side	
12.2 m (40 ft.)	12 950 (28,550)	12 950 (28,550)									
10.7 m (35 ft.)	13 730 (30,260)	13 730 (30,260)	11 780 (25,970)	11 780 (25,970)							
9.1 m (30 ft.)			11 180 (24,640)	11 180 (24,640)	9960 (21,950)	9640 (21,240)					
7.6 m (25 ft.)			11 210 (24,710)	11 210 (24,710)	9840 (21,700)	9670 (21,310)	8750 (19,280)	7140 (15,730)			
6.1 m (20 ft.)	14 140 (31,170)	14 140 (31,170)	11 720 (25,830)	11 720 (25,830)	10 040 (22,140)	9530 (21,000)	8740 (19,260)	7110 (15,680)			
4.6 m (15 ft.)	16 000 (35,260)	16 000 (35,260)	12 570 (27,710)	12 570 (27,710)	10 410 (22,940)	9270 (20,440)	8820 (19,450)	6990 (15,410)	7280 (16,040)	5450 (12,020)	
3.1 m (10 ft.)	18 050 (39,770)	18 050 (39,770)	13 440 (29,620)	12 500 (27,550)	10 740 (23,680)	8960 (19,740)	8850 (19,510)	6830 (15,040)	7110 (15,680)	5400 (11,900)	
1.5 m (5 ft.)	18 980 (41,830)	18 360 (40,460)	13 840 (30,500)	11 930 (26,290)	10 800 (23,810)	8650 (19,070)	8660 (19,090)	6660 (14,680)	6630 (14,600)	5330 (11,750)	
Ground Line	17 980 (39,630)	17 680 (38,970)	13 350 (29,430)	11 530 (25,410)	10 330 (22,770)	8420 (18,560)	8050 (17,740)	6540 (14,410)	5520 (12,180)	5300 (11,680)	
-1.5 m (-5 ft.)	15 240 (33,600)	15 240 (33,600)	11 770 (25,950)	11 340 (24,980)	9090 (20,030)	8300 (18,290)	6740 (14,850)	6490 (14,300)			
-3.1 m (-10 ft.)			8980 (19,800)	8980 (19,800)							

Lift Capacity — 3156G VIH Log Loader with 2.92-m (9 ft. 7 in.) undercarriage and 700-mm (28 in.) shoes; bare pin

Load Point Height	4.6 m (15 ft.)		6.1 m (20 ft.)		7.6 m (25 ft.)		9.1 m (30 ft.)		10.7 m (35 ft.)		
	Over Front	Over Side	Over Front	Over Side	Over Front	Over Side	Over Front	Over Side	Over Front	Over Side	
12.2 m (40 ft.)	14 950 (32,960)	14 950 (32,960)									
10.7 m (35 ft.)	13 920 (30,680)	13 920 (30,680)	11 990 (26,430)	11 990 (26,430)							
9.1 m (30 ft.)			11 390 (25,110)	11 390 (25,110)	10 170 (22,420)	9780 (21,550)					
7.6 m (25 ft.)			11 440 (25,210)	11 440 (25,210)	10 070 (22,190)	9820 (21,650)	8970 (19,760)	7290 (16,080)			
6.1 m (20 ft.)	14 420 (31,770)	14 420 (31,770)	11 980 (26,400)	11 980 (26,400)	10 280 (22,670)	9700 (21,390)	8970 (19,770)	7290 (16,060)			
4.6 m (15 ft.)	16 320 (35,970)	16 320 (35,970)	12 850 (28,320)	12 850 (28,320)	10 660 (23,500)	9470 (20,870)	9060 (19,970)	7180 (15,820)	7450 (16,430)	5630 (12,410)	
3.1 m (10 ft.)			13 740 (30,280)	12 730 (28,070)	11 010 (24,270)	9170 (20,220)	9100 (20,050)	7030 (15,490)	7330 (16,140)	5590 (12,310)	
1.5 m (5 ft.)			14 150 (31,180)	12 190 (26,870)	11 080 (24,410)	8890 (19,590)	8910 (19,640)	6880 (15,160)	6830 (15,060)	5530 (12,190)	
Ground Line	18 310 (40,360)	18 030 (39,740)	13 660 (30,100)	11 810 (26,030)	10 600 (23,370)	8670 (19,100)	8290 (18,270)	6760 (14,900)	5700 (12,560)	5500 (12,130)	
-1.5 m (-5 ft.)	15 540 (34,260)	15 540 (34,260)	12 060 (26,580)	11 630 (25,630)	9350 (20,600)	8550 (18,850)	6960 (15,350)	6710 (14,800)			

Lift Capacity — 3156G Live-Heel Log Loader with 2.92-m (9 ft. 7 in.) undercarriage and 700-mm (28 in.) shoes; bare pin

Load Point Height	4.6 m (15 ft.)		6.1 m (20 ft.)		7.6 m (25 ft.)		9.1 m (30 ft.)		10.7 m (35 ft.)		12.2 m (40 ft.)	
	Over Front	Over Side	Over Front	Over Side	Over Front	Over Side	Over Front	Over Side	Over Front	Over Side	Over Front	Over Side
12.2 m (40 ft.)	13 500 (29,750)	13 500 (29,750)	11 560 (25,470)	11 560 (25,470)								
10.7 m (35 ft.)			10 330 (22,770)	10 330 (22,770)	9260 (20,410)	8810 (19,420)	7020 (15,480)	6770 (14,930)				
9.1 m (30 ft.)			9990 (22,010)	9990 (22,010)	8870 (19,540)	8870 (19,540)	7950 (17,530)	6500 (14,320)				
7.6 m (25 ft.)			10 130 (22,320)	10 130 (22,320)	8910 (19,630)	8910 (19,630)	7880 (17,370)	6750 (14,880)	6930 (15,280)	5370 (11,830)		
6.1 m (20 ft.)			10 830 (23,870)	10 830 (23,870)	9260 (20,400)	9260 (20,400)	8010 (17,660)	6760 (14,900)	6920 (15,250)	5370 (11,830)		
4.6 m (15 ft.)			11 010 (24,260)	11 010 (24,260)	9750 (21,490)	9090 (20,040)	8220 (18,110)	6680 (14,730)	6960 (15,330)	5290 (11,660)	5630 (12,410)	4110 (9,060)
3.1 m (10 ft.)			12 110 (26,680)	12 110 (26,680)	10 230 (22,540)	8820 (19,430)	8380 (18,470)	6560 (14,460)	6980 (15,380)	5190 (11,440)	5520 (12,160)	4090 (9,010)
1.5 m (5 ft.)			13 280 (29,260)	12 160 (26,790)	10 470 (23,080)	8500 (18,730)	8420 (18,560)	6490 (14,300)	6860 (15,120)	5070 (11,180)	5110 (11,270)	4050 (8,920)
Ground Line	12 660 (27,900)	12 660 (27,900)	13 460 (29,660)	11 570 (25,510)	10 360 (22,840)	8310 (18,310)	8230 (18,130)	6310 (13,900)	6470 (14,260)	4960 (10,930)	4170 (9,200)	4020 (8,870)
-1.5 m (-5 ft.)	10 190 (22,450)	10 190 (22,450)	12 740 (28,070)	11 140 (24,560)	9760 (21,520)	8030 (17,700)	7580 (16,700)	6160 (13,570)	5600 (12,340)	4890 (10,780)		
-3.1 m (-10 ft.)	11 230 (24,760)	11 230 (24,760)	10 980 (24,200)	10 920 (24,060)	8390 (18,490)	7900 (17,410)	6230 (13,730)	6090 (13,420)				

3754G

Engine		3754G Road Builder	Optional engine for use in Canada, Australia, and New Zealand
		Base engine for use in U.S. and U.S. Territories	
Manufacturer and Model		John Deere PowerTech™ PSS 9.0 L	John Deere PowerTech™ Plus 9.0 L
Non-Road Emission Standards		EPA Final Tier 4/EU Stage IV	EPA Tier 3/EU Stage IIIA
Net Rated Power (ISO 9249)		202 kW (271 hp) at 1,900 rpm	202 kW (271 hp) at 1,900 rpm
Cylinders		6	6
Engine Displacement		9.0 L (549 cu. in.)	9.0 L (549 cu. in.)
Off-Level Capacity		70% (35 deg.)	70% (35 deg.)
Aspiration		Series turbocharged, air-to-air charge-air cooler	Turbocharged, air-to-air charge-air cooler
Oil Filter, Remote Mounted		Full-flow spin-on filter	Full-flow spin-on filter
Cooling			
Fan Drive		Cool-on-demand hydraulic-driven, suction-type fan remote-mounted drive w/ optional reversing fan	
Powertrain			
2-speed propel with automatic shift			
Maximum Travel Speed			
Low		3.1 km/h (1.9 mph)	
High		4.5 km/h (2.8 mph)	
Drawbar Pull		36 102 kgf (79,590 lbf)	
Hydraulics			
Open center, pilot operated			
Main Pumps			
		2 variable-displacement pumps	
Maximum Rated Flow x 2		288 L/m (76.1 gpm)	
System Operating Pressure			
Implement Circuits		34 300 kPa (4,975 psi)	
Power Boost		38 000 kPa (5,511 psi)	
Controls		Pilot levers; short-stroke, low-effort hydraulic pilot with shutoff lever	
Electrical			
		<i>EPA Final Tier 4/EU Stage IV</i>	<i>EPA Tier 3/EU Stage IIIA</i>
System Voltage		24 volt	24 volt
Alternator Rating		150 amp	130 amp
Lights			
Work		5 halogen: 3 cab front and 2 right-hand front log deflector standard / 14 LEDs optional	
Access (optional)		1 LED (rear right cab)	1 LED (rear right cab)
Service		5 LEDs (compartment and engine hood)	5 LEDs (compartment and engine hood)
Undercarriage			
		<i>Standard</i>	<i>Optional LC</i>
Rollers (per side)			
Carrier		2	2
Track		8	9
Shoes, Double Grousers (per side)		49	53
Undercarriage Pitch		216 mm (8.5 in.)	216 mm (8.5 in.)



Ground Pressure **3754G Road Builder**

700-mm (28 in.) Double-Grouser Shoes 67.6 kPa (9.8 psi)

Swing Mechanism

Swing Speed 11.0 rpm

Swing Torque 120 000 Nm (88,507 lb.-ft.)

Operator's Station

Operator Height from Ground (eye level), 3125 mm (10 ft. 2 in.)

Side-Entry Forestry Cab

Serviceability

Refill Capacities

Fuel Tank 1080.0 L (285.0 gal.)

Cooling System 39.7 L (10.5 gal.)

Diesel Exhaust Fluid (DEF) Tank (FT4) 43.6 L (11.5 gal.)

Engine Crankcase (including filter) 27.0 L (28.5 qt.)

Hydraulic Tank Oil 195.0 L (52.0 gal.)

Operating Weights

With full fuel tank, 79-kg (175 lb.) operator, side-entry forestry cab, 5538-kg (12,206 lb.) counterweight, 700-mm (28 in.) double-grouser shoes, FT4 engine, and 2.92-m (9 ft. 7 in.) undercarriage; no attachment included

EPA Final Tier 4/EU Stage IV EPA Tier 3/EU Stage IIIA

SAE Operating Weight 43 143 kg (95,114 lb.) 42 916 kg (94,614 lb.)

Optional Components (add weight)

Rear-Entry Cab 671 kg (1,480 lb.) 671 kg (1,480 lb.)

LC Undercarriage 716 kg (1,578 lb.) 716 kg (1,578 lb.)

Operating Dimensions

With 700-mm (28 in.) shoes; 5538-kg (12,206 lb.) counterweight; 3.2-m (10 ft. 6 in.) arm; 1160-kg (2,557 lb.), 1.76-m³ (2.3 cu. yd.), 1370-mm (54 in.) bucket; full fuel tank; 79-kg (175 lb.) operator, and standard equipment

A Maximum Reach 11.05 m (36 ft. 3 in.)

A' Maximum Reach at Ground Level 10.80 m (35 ft. 5 in.)

B Maximum Digging Depth 7.14 m (23 ft. 5 in.)

C Maximum Cutting Height 10.52 m (34 ft. 6 in.)

D Maximum Dumping Log-Level Height 7.62 m (25 ft. 0 in.)

E Minimum Swing Radius 4.45 m (14 ft. 7 in.)

F Tail Swing Radius 3.68 m (12 ft. 1 in.)

3754G Road Builder

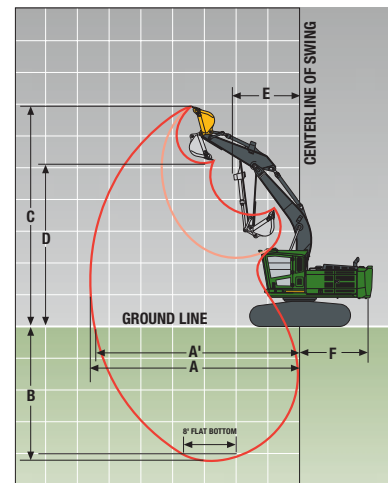

Machine not exactly as shown. Illustrations for dimensioning purposes only.

3754G

Machine Dimensions	3754G Road Builder	
	Standard	Optional LC
Undercarriage		
A Height (side-entry cab)	3.81 m (12 ft. 6 in.)	3.81 m (12 ft. 6 in.)
B Overall Length	11.15 m (36 ft. 7 in.)	11.15 m (36 ft. 7 in.)
C Rear-End Length / Swing Radius	3.61 m (11 ft. 10 in.)	3.61 m (11 ft. 10 in.)
D Distance Between Idler / Sprocket Centerline	4.04 m (13 ft. 3 in.)	4.47 m (14 ft. 8 in.)
E Undercarriage Length	4.95 m (16 ft. 3 in.)	5.46 m (17 ft. 11 in.)
F Counterweight Clearance	1.45 m (4 ft. 9 in.)	1.45 m (4 ft. 9 in.)
G Upperstructure Width	3.48 m (11 ft. 5 in.)	3.48 m (11 ft. 5 in.)
H Cab Height (side-entry cab)	3.81 m (12 ft. 6 in.)	3.81 m (12 ft. 6 in.)
I Track Width with 700-mm (28 in.) Double-Grouser Shoes	0.71 m (28 in.)	0.71 m (28 in.)
J Center of Sprocket to Center of Sprocket (gauge width)	2.92 m (9 ft. 7 in.)	2.92 m (9 ft. 7 in.)
K Ground Clearance	0.74 m (29 in.)	0.74 m (29 in.)
L Undercarriage Width with 700-mm (28 in.) Double-Grouser Shoes	3.63 m (11 ft. 11 in.)	3.63 m (11 ft. 11 in.)

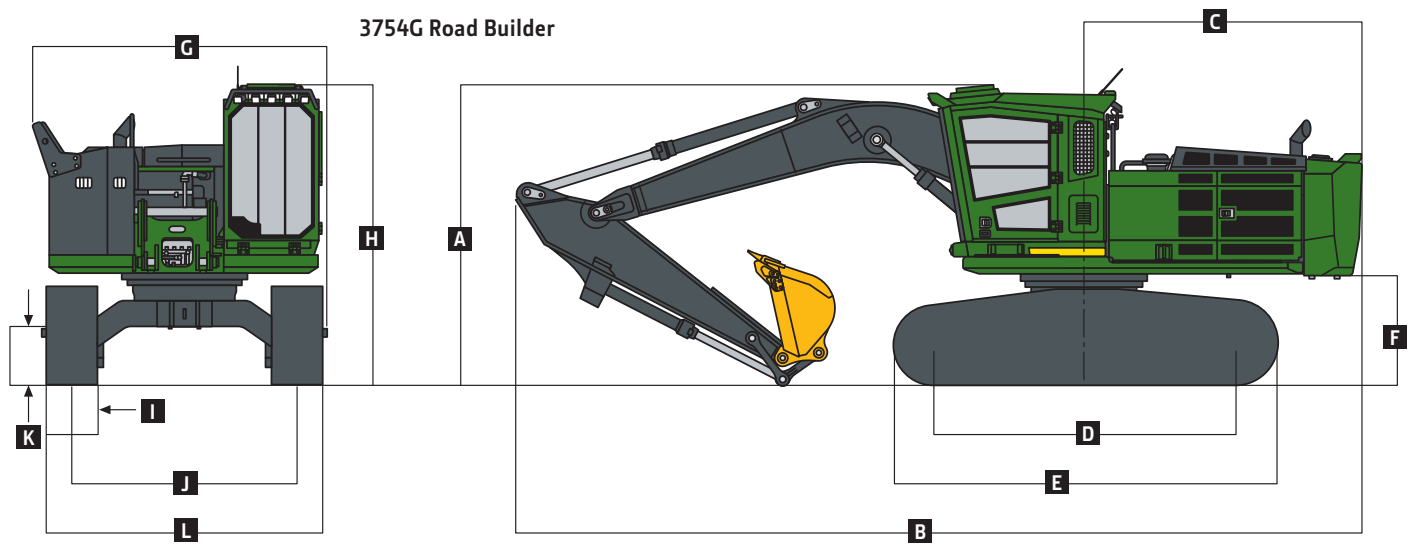

Attachment weight is not included when calculating the lift capacities.

Boldface type indicates hydraulic-limited capacities with power boost; lightface type indicates stability-limited capacities, in kg (lb.).
Figures do not exceed 87 percent of hydraulic capacities or 75 percent of weight needed to tip machine.

Lift Capacity — 3754G Road Builder with 2.92-m (9 ft. 7 in.) undercarriage and 700-mm (28 in.) shoes; bare pin										
Load Point Height	3.1 m (10 ft.)		4.6 m (15 ft.)		6.1 m (20 ft.)		7.6 m (25 ft.)		9.1 m (30 ft.)	
	Over Front	Over Side	Over Front	Over Side	Over Front	Over Side	Over Front	Over Side	Over Front	Over Side
7.6 m (25 ft.)							8270	8270		
							(18,220)	(18,220)		
6.1 m (20 ft.)							8340	8340		
							(18,380)	(18,380)		
4.6 m (15 ft.)			12 810	12 810	10 210	10 210	8900	8900	8240	6950
			(28,220)	(28,220)	(22,510)	(22,510)	(19,610)	(19,610)	(18,160)	(15,330)
3.1 m (10 ft.)			15 860	15 860	11 670	11 670	9630	8920	8490	6820
			(34,960)	(34,960)	(25,710)	(25,710)	(21,220)	(19,670)	(18,710)	(15,040)
1.5 m (5 ft.)			17 880	17 790	12 870	11 750	10 290	8620	8740	6680
			(39,410)	(39,220)	(28,360)	(25,910)	(22,670)	(19,000)	(19,260)	(14,730)
Ground Line	26 160	26 160	18 380	17 390	13 470	11 420	10 640	8420		
	(57,650)	(57,650)	(40,510)	(38,320)	(29,700)	(25,170)	(23,450)	(18,550)		
-1.5 m (-5 ft.)	24 600	24 600	17 740	17 350	13 330	11 310	10 450	8350		
	(54,210)	(54,210)	(39,100)	(38,240)	(29,380)	(24,930)	(23,040)	(18,410)		
-3.1 m (-10 ft.)	21 620	21 620	16 030	16 030	12 230	11 410	9200	8490		
	(47,640)	(47,640)	(35,330)	(35,330)	(26,960)	(25,150)	(20,280)	(18,700)		
-4.6 m (-15 ft.)	16 620	16 620	12 720	12 720	9320	9320				
	(36,630)	(36,630)	(28,030)	(28,030)	(20,530)	(20,530)				

3756G

Engine	3756G Processor / Valve-in-Head (VIH) Log Loader / Live-Heel Log Loader	
	Base engine for use in U.S. and U.S. Territories	Optional engine for use in Canada, Australia, and New Zealand
Manufacturer and Model	John Deere PowerTech™ PSS 9.0 L	John Deere PowerTech™ Plus 9.0 L
Non-Road Emission Standards	EPA Final Tier 4/EU Stage IV	EPA Tier 3/EU Stage IIIA
Net Rated Power (ISO 9249)	202 kW (271 hp) at 1,900 rpm	202 kW (271 hp) at 1,900 rpm
Cylinders	6	6
Engine Displacement	9.0 L (549 cu. in.)	9.0 L (549 cu. in.)
Off-Level Capacity	70% (35 deg.)	70% (35 deg.)
Aspiration	Series turbocharged, air-to-air charge-air cooler	Turbocharged, air-to-air charge-air cooler
Oil Filter, Remote Mounted	Full-flow spin-on filter	Full-flow spin-on filter
Cooling	Cool-on-demand hydraulic-driven, suction-type fan remote-mounted drive w/ optional reversing fan	
Powertrain	2-speed propel with automatic shift	
Maximum Travel Speed		
Low	3.1 km/h (1.9 mph)	
High	4.5 km/h (2.8 mph)	
Drawbar Pull	36 102 kgf (79,590 lbf)	
Hydraulics	Open center, pilot operated	
Main Pumps	2 variable-displacement pumps	
Maximum Rated Flow x 2	288 L/m (76.1 gpm)	
System Operating Pressure		
Implement Circuits	34 300 kPa (4,975 psi)	
Power Boost	38 000 kPa (5,511 psi)	
Controls	Pilot levers; short-stroke, low-effort hydraulic pilot with shutoff lever	
Electrical	EPA Final Tier 4/EU Stage IV	
System Voltage	24 volt	EPA Tier 3/EU Stage IIIA 24 volt
Alternator Rating	150 amp	130 amp
Lights		
Work	5 halogen: 3 cab front and 2 right-hand front log deflector standard / 14 LEDs optional	
Access (optional)	1 LED (rear right cab)	
Service	5 LEDs (compartment and engine hood)	5 LEDs (compartment and engine hood)



Undercarriage	3756G Processor / VIH Log Loader / Live-Heel Log Loader					
	<i>Standard</i>			<i>Optional LC</i>		
Rollers (per side)						
Carrier	2		2			
Track	8		9			
Shoes, Double Grousers (per side)	49		53			
Undercarriage Pitch	216 mm (8.5 in.)		216 mm (8.5 in.)			
Ground Pressure	3756G Processor		3756G VIH Log Loader		3756G Live-Heel Log Loader	
700-mm (28 in.) Double-Grouser Shoes	79.3 kPa (11.5 psi)		75.8 kPa (11.0 psi)		74.5 kPa (10.8 psi)	
Swing Mechanism	3756G Processor / VIH Log Loader / Live-Heel Log Loader					
Swing Speed	11.0 rpm					
Swing Torque						
Standard	120 000 Nm (88,507 lb.-ft.)					
Optional	148 462 Nm (109,500 lb.-ft.)					
Operator's Station						
Operator Height from Ground (eye level)						
Side-Entry Forestry Cab	3125 mm (10 ft. 2 in.)					
Rear-Entry Log Loader Cab	4471 mm (14 ft. 7 in.)					
Serviceability						
Refill Capacities						
Fuel Tank	1080.0 L (285.0 gal.)					
Cooling System	39.7 L (10.5 gal.)					
Diesel Exhaust Fluid (DEF) Tank (FT4)	43.6 L (11.5 gal.)					
Engine Crankcase (including filter)	27.0 L (28.5 qt.)					
Hydraulic Tank Oil	195.0 L (52.0 gal.)					
Operating Weights	3756G Processor		3756G VIH Log Loader		3756G Live-Heel Log Loader	
With full fuel tank, 79-kg (175 lb.) operator, rear-entry log loader cab, 7975-kg (17,577 lb.) counterweight, 700-mm (28 in.) double-grouser shoes, FT4 engine, and 2.92-m (9 ft. 7 in.) LC undercarriage; no attachment included						
	<i>EPA Final Tier 4/ EU Stage IV</i>	<i>EPA Tier 3/ EU Stage IIIA</i>	<i>EPA Final Tier 4/ EU Stage IV</i>	<i>EPA Tier 3/ EU Stage IIIA</i>	<i>EPA Final Tier 4/ EU Stage IV</i>	<i>EPA Tier 3/ EU Stage IIIA</i>
SAE Operating Weight	48 471 kg (106,861 lb.)	48 245 kg (106,361 lb.)	48 032 kg (105,893 lb.)	47 806 kg (105,393 lb.)	48 852 kg (107,700 lb.)	48 625 kg (107,200 lb.)
Optional Components (add weight)						
Side-Entry Cab	-671 kg (-1,480 lb.)	-671 kg (-1,480 lb.)	-671 kg (-1,480 lb.)	-671 kg (-1,480 lb.)	-671 kg (-1,480 lb.)	-671 kg (-1,480 lb.)
Standard Track Frame	-716 kg (-1,578 lb.)	-716 kg (-1,578 lb.)	-716 kg (-1,578 lb.)	-716 kg (-1,578 lb.)	-716 kg (-1,578 lb.)	-716 kg (-1,578 lb.)

Operating Dimensions	3756G Processor	3756G VIH Log Loader	3756G Live-Heel Log Loader
With 700-mm (28 in.) shoes; 7975-kg (17,577 lb.) counterweight; full fuel tank; 79-kg (175 lb.) operator, and standard equipment			
	4.88-m (16 ft. 0 in.) <i>Processor Arm</i>	4.88-m (16 ft. 0 in.) <i>VIH Log Loader Arm</i>	4.88-m (16 ft. 0 in.) <i>Live-Heel Log Loader Arm</i>
A Maximum Reach	11.63 m (38 ft. 2 in.)	11.68 m (38 ft. 4 in.)	13.13 m (43 ft. 1 in.)
A ^l Maximum Reach at Ground Level	11.40 m (37 ft. 5 in.)	11.46 m (37 ft. 7 in.)	12.90 m (42 ft. 4 in.)
B Maximum Working Depth	3.94 m (12 ft. 11 in.)	3.91 m (12 ft. 10 in.)	5.31 m (17 ft. 5 in.)
C Maximum Working Height	13.59 m (44 ft. 7 in.)	13.72 m (45 ft. 0 in.)	15.14 m (49 ft. 8 in.)
D Maximum Log-Level Height	9.93 m (32 ft. 7 in.)	9.53 m (31 ft. 3 in.)*	9.30 m (30 ft. 6 in.)
E Minimum Swing Radius	4.90 m (16 ft. 1 in.)	4.75 m (15 ft. 7 in.)	4.78 m (15 ft. 8 in.)
F Tail Swing Radius	3.71 m (12 ft. 2 in.)	3.71 m (12 ft. 2 in.)	3.71 m (12 ft. 2 in.)

*Attachment dependent.

3756G Processor

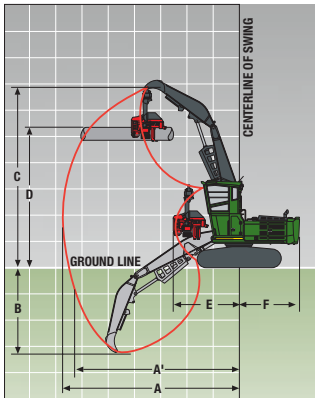

3756G VIH

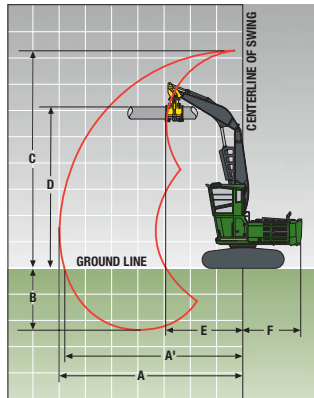

3756G Live Heel

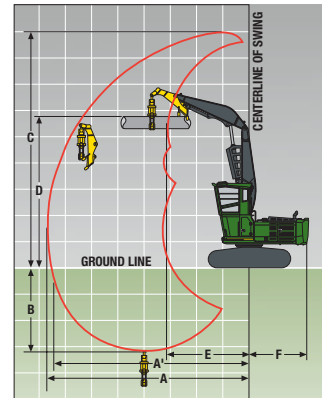

Machine Dimensions	3756G Processor	3756G VIH Log Loader	3756G Live-Heel Log Loader
A Height (rear-entry cab)	3.68 m (12 ft. 1 in.)	3.68 m (12 ft. 1 in.)	3.68 m (12 ft. 1 in.)
B Overall Length	15.37 m (50 ft. 5 in.)	15.98 m (52 ft. 5 in.)	16.59 m (54 ft. 5 in.)
C Rear-End Length / Swing Radius	3.63 m (11 ft. 11 in.)	3.63 m (11 ft. 11 in.)	3.63 m (11 ft. 11 in.)
D Distance Between Idler / Sprocket Centerline (LC)	4.47 m (14 ft. 8 in.)	4.47 m (14 ft. 8 in.)	4.47 m (14 ft. 8 in.)
E Undercarriage Length (LC)	5.46 m (17 ft. 11 in.)	5.46 m (17 ft. 11 in.)	5.46 m (17 ft. 11 in.)
F Counterweight Clearance	1.47 m (4 ft. 10 in.)	1.47 m (4 ft. 10 in.)	1.47 m (4 ft. 10 in.)
G Upperstructure Width	3.48 m (11 ft. 5 in.)	3.48 m (11 ft. 5 in.)	3.48 m (11 ft. 5 in.)
H Cab Height (rear-entry cab)	5.18 m (17 ft. 0 in.)	5.18 m (17 ft. 0 in.)	5.18 m (17 ft. 0 in.)
H ^l Tilted Cab Height (rear-entry cab)	3.68 m (12 ft. 1 in.)	3.68 m (12 ft. 1 in.)	3.68 m (12 ft. 1 in.)
I Track Width with 700-mm (28 in.) Double-Grouser Shoes	0.71 m (28 in.)	0.71 m (28 in.)	0.71 m (28 in.)
J Center of Sprocket to Center of Sprocket (gauge width)	2.92 m (9 ft. 7 in.)	2.92 m (9 ft. 7 in.)	2.92 m (9 ft. 7 in.)
K Ground Clearance	0.74 m (29 in.)	0.74 m (29 in.)	0.74 m (29 in.)
L Undercarriage Width with 700-mm (28 in.) Double-Grouser Shoes	3.63 m (11 ft. 11 in.)	3.63 m (11 ft. 11 in.)	3.63 m (11 ft. 11 in.)

3756G Processor – Side-Entry Cab

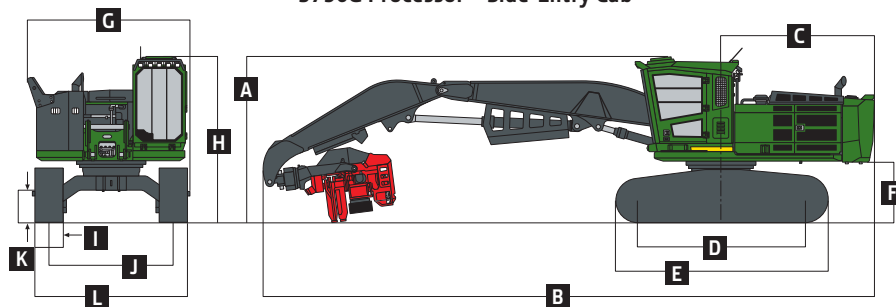

3756G Processor – Rear-Entry Cab

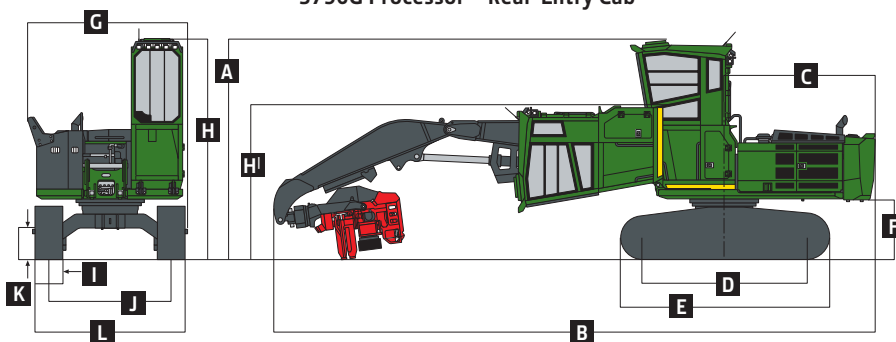

3756G VIH

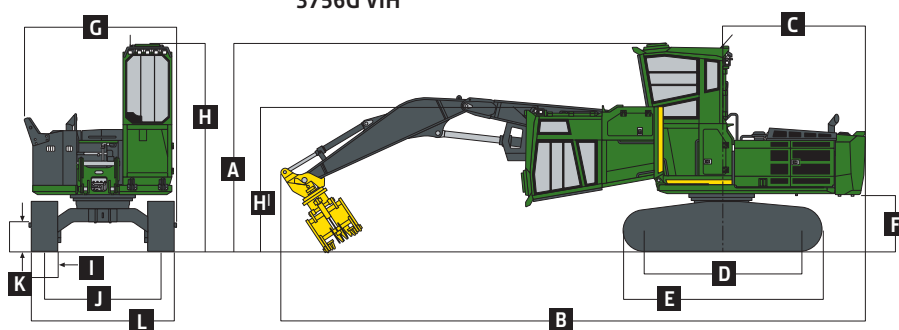

3756G Live Heel

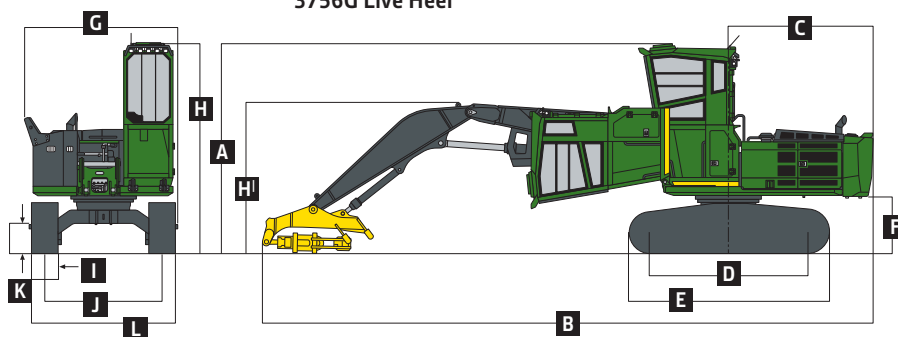

Lift Capacity — 3756G Processor with 2.92-m (9 ft. 7 in.) undercarriage and 700-mm (28 in.) shoes; bare pin										
Load Point Height	4.6 m (15 ft.)		6.1 m (20 ft.)		7.6 m (25 ft.)		9.1 m (30 ft.)		10.7 m (35 ft.)	
	Over Front	Over Side	Over Front	Over Side	Over Front	Over Side	Over Front	Over Side	Over Front	Over Side
12.2 m (40 ft.)	17 570 (38,730)	17 570 (38,730)								
10.7 m (35 ft.)			15 490 (34,130)	15 490 (34,130)	12 830 (28,270)	11 110 (24,490)				
9.1 m (30 ft.)			14 980 (33,020)	14 980 (33,020)	13 530 (29,820)	11 350 (25,010)	10 840 (23,900)	8280 (18,260)		
7.6 m (25 ft.)			15 250 (33,600)	15 250 (33,600)	13 570 (29,900)	11 300 (24,910)	10 930 (24,100)	8370 (18,450)		
6.1 m (20 ft.)	17 100 (37,680)	17 100 (37,680)	16 170 (35,640)	15 810 (34,850)	14 000 (30,860)	11 080 (24,430)	10 840 (23,880)	8280 (18,250)	8400 (18,520)	6390 (14,080)
4.6 m (15 ft.)	21 700 (47,820)	21 700 (47,820)	17 560 (38,710)	15 170 (33,430)	14 180 (31,250)	10 730 (23,660)	10 640 (23,450)	8090 (17,840)	8340 (18,380)	6330 (13,950)
3.1 m (10 ft.)	25 330 (55,820)	22 470 (49,520)	18 980 (41,840)	14 390 (31,710)	13 730 (30,260)	10 320 (22,740)	10 400 (22,920)	7870 (17,340)	8230 (18,130)	6220 (13,710)
1.5 m (5 ft.)	26 940 (59,380)	20 980 (46,230)	18 700 (41,220)	13 660 (30,110)	13 300 (29,320)	9920 (21,870)	10 160 (22,400)	7640 (16,840)	8110 (17,870)	6110 (13,470)
Ground Line	25 980 (57,270)	20 120 (44,350)	18 130 (39,970)	13 150 (28,980)	12 970 (28,590)	9620 (21,200)	9980 (21,990)	7470 (16,460)	8030 (17,700)	6040 (13,300)
-1.5 m (-5 ft.)	22 760 (50,170)	19 820 (43,690)	17 600 (38,800)	12 890 (28,410)	12 790 (28,190)	9450 (20,820)	9880 (21,780)	7380 (16,260)	7310 (16,110)	6040 (13,310)
-3.1 m (-10 ft.)	17 720 (39,050)	17 720 (39,050)	14 320 (31,560)	12 860 (28,340)	11 210 (24,720)	9420 (20,770)	8120 (17,900)	7400 (16,320)		

Lift Capacity — 3756G Processor with 2.92-m (9 ft. 7 in.) LC undercarriage and 700-mm (28 in.) shoes; bare pin										
Load Point Height	4.6 m (15 ft.)		6.1 m (20 ft.)		7.6 m (25 ft.)		9.1 m (30 ft.)		10.7 m (35 ft.)	
	Over Front	Over Side	Over Front	Over Side	Over Front	Over Side	Over Front	Over Side	Over Front	Over Side
12.2 m (40 ft.)	17 570 (38,730)	17 570 (38,730)								
10.7 m (35 ft.)			15 490 (34,130)	15 490 (34,130)	12 830 (28,270)	11 250 (24,800)				
9.1 m (30 ft.)			14 980 (33,020)	14 980 (33,020)	13 530 (29,820)	11 490 (25,320)	11 140 (24,540)	8400 (18,510)		
7.6 m (25 ft.)			15 250 (33,600)	15 250 (33,600)	13 570 (29,900)	11 440 (25,220)	12 220 (26,940)	8480 (18,700)		
6.1 m (20 ft.)	17 100 (37,680)	17 100 (37,680)	16 170 (35,640)	16 000 (35,270)	14 000 (30,860)	11 230 (24,740)	12 340 (27,210)	8390 (18,500)	9580 (21,120)	6480 (14,290)
4.6 m (15 ft.)	21 700 (47,820)	21 700 (47,820)	17 560 (38,710)	15 360 (33,850)	14 670 (32,320)	10 880 (23,970)	12 150 (26,780)	8210 (18,090)	9520 (20,980)	6420 (14,160)
3.1 m (10 ft.)	25 330 (55,820)	22 760 (50,150)	18 980 (41,840)	14 580 (32,130)	15 300 (33,720)	10 460 (23,060)	11 900 (26,230)	7980 (17,590)	9400 (20,730)	6320 (13,920)
1.5 m (5 ft.)	26 940 (59,380)	21 260 (46,870)	19 770 (43,570)	13 850 (30,530)	15 340 (33,810)	10 060 (22,180)	11 660 (25,690)	7760 (17,090)	9290 (20,470)	6210 (13,680)
Ground Line	25 980 (57,270)	20 410 (44,990)	19 390 (42,730)	13 340 (29,400)	15 000 (33,060)	9760 (21,510)	11 470 (25,270)	7580 (16,710)	9200 (20,290)	6130 (13,510)
-1.5 m (-5 ft.)	22 760 (50,170)	20 110 (44,320)	17 600 (38,800)	13 080 (28,830)	13 810 (30,430)	9590 (21,130)	10 740 (23,680)	7490 (16,510)	7310 (16,110)	6130 (13,510)
-3.1 m (-10 ft.)	17 720 (39,050)	17 720 (39,050)	14 320 (31,560)	13 050 (28,760)	11 210 (24,720)	9560 (21,080)	8120 (17,900)	7520 (16,570)		

Lift Capacity — 3756G VH Log Loader with 2.92-m (9 ft. 7 in.) undercarriage and 700-mm (28 in.) shoes; bare pin										
Load Point Height	4.6 m (15 ft.)		6.1 m (20 ft.)		7.6 m (25 ft.)		9.1 m (30 ft.)		10.7 m (35 ft.)	
	Over Front	Over Side	Over Front	Over Side	Over Front	Over Side	Over Front	Over Side	Over Front	Over Side
12.2 m (40 ft.)	19 020 (41,930)	19 020 (41,930)	14 360 (31,650)	14 360 (31,650)						
10.7 m (35 ft.)			15 700 (34,610)	15 700 (34,610)	14 210 (31,320)	11 110 (24,490)				
9.1 m (30 ft.)			15 210 (33,530)	15 210 (33,530)	13 750 (30,310)	11 370 (25,050)	11 090 (24,450)	8340 (18,390)		
7.6 m (25 ft.)			15 500 (34,160)	15 500 (34,160)	13 800 (30,420)	11 340 (25,000)	11 200 (24,690)	8450 (18,620)		
6.1 m (20 ft.)	15 540 (34,250)	15 540 (34,250)	16 440 (36,240)	15 800 (34,820)	14 250 (31,420)	11 140 (24,560)	11 120 (24,520)	8370 (18,450)	8660 (19,090)	6490 (14,310)
4.6 m (15 ft.)	18 320 (40,390)	18 320 (40,390)	17 860 (39,360)	15 190 (33,470)	14 520 (32,000)	10 820 (23,840)	10 940 (24,120)	8200 (18,080)	8610 (18,980)	6450 (14,210)
3.1 m (10 ft.)			19 290 (42,510)	14 440 (31,820)	14 090 (31,060)	10 420 (22,970)	10 710 (23,610)	7990 (17,600)	8510 (18,750)	6350 (14,000)
1.5 m (5 ft.)			19 160 (42,230)	13 740 (30,280)	13 680 (30,150)	10 040 (22,130)	10 490 (23,120)	7780 (17,140)	8400 (18,520)	6250 (13,770)
Ground Line	26 280 (57,930)	20 110 (44,320)	18 610 (41,020)	13 240 (29,190)	13 360 (29,450)	9750 (21,480)	10 310 (22,730)	7610 (16,770)	8330 (18,350)	6180 (13,620)
-1.5 m (-5 ft.)	23 020 (50,740)	19 820 (43,680)	17 860 (39,370)	13 000 (28,640)	13 180 (29,060)	9580 (21,120)	10 220 (22,530)	7520 (16,580)	7460 (16,430)	6180 (13,630)
-3.1 m (-10 ft.)	17 940 (39,540)	17 940 (39,540)	14 550 (32,070)	12 970 (28,590)	11 430 (25,200)	9560 (21,080)	8310 (18,310)	7550 (16,640)		

Attachment weight is not included when calculating the lift capacities. Boldface type indicates hydraulic-limited capacities with power boost; lightface type indicates stability-limited capacities, in kg (lb.).
 Figures do not exceed 87 percent of hydraulic capacities or 75 percent of weight needed to tip machine.

3756G

Lift Capacity — 3756G VIH Log Loader with 2.92-m (9 ft. 7 in.) LC undercarriage and 700-mm (28 in.) shoes; bare pin

Load Point Height	4.6 m (15 ft.)		6.1 m (20 ft.)		7.6 m (25 ft.)		9.1 m (30 ft.)		10.7 m (35 ft.)	
	Over Front	Over Side	Over Front	Over Side	Over Front	Over Side	Over Front	Over Side	Over Front	Over Side
12.2 m (40 ft.)	19 020 (41,930)	19 020 (41,930)	14 360 (31,650)	14 360 (31,650)						
10.7 m (35 ft.)			15 700 (34,610)	15 700 (34,610)	14 210 (31,320)	11 390 (25,100)				
9.1 m (30 ft.)			15 210 (33,530)	15 210 (33,530)	13 750 (30,310)	11 640 (25,660)	12 440 (27,410)	8550 (18,840)		
7.6 m (25 ft.)			15 500 (34,160)	15 500 (34,160)	13 800 (30,420)	11 620 (25,610)	12 450 (27,440)	8660 (19,080)		
6.1 m (20 ft.)	15 540 (34,250)	15 540 (34,250)	16 440 (36,240)	16 200 (35,710)	14 250 (31,420)	11 420 (25,170)	12 540 (27,640)	8580 (18,910)	9760 (21,520)	6660 (14,680)
4.6 m (15 ft.)	18 320 (40,390)	18 320 (40,390)	17 860 (39,360)	15 580 (34,350)	14 930 (32,900)	11 090 (24,440)	12 360 (27,230)	8410 (18,530)	9710 (21,410)	6610 (14,580)
3.1 m (10 ft.)			19 290 (42,510)	14 830 (32,690)	15 570 (34,320)	10 690 (23,560)	12 120 (26,710)	8190 (18,060)	9610 (21,170)	6520 (14,360)
1.5 m (5 ft.)			20 070 (44,240)	14 130 (31,140)	15 600 (34,380)	10 310 (22,720)	11 890 (26,200)	7980 (17,590)	9500 (20,930)	6410 (14,130)
Ground Line	26 280 (57,930)	20 770 (45,770)	19 670 (43,360)	13 360 (30,040)	15 270 (33,650)	10 010 (22,070)	11 710 (25,800)	7810 (17,220)	9420 (20,760)	6340 (13,980)
-1.5 m (-5 ft.)	23 020 (50,740)	20 470 (45,130)	17 860 (39,370)	13 380 (29,490)	14 050 (30,980)	9850 (21,710)	10 960 (24,160)	7730 (17,030)	7460 (16,430)	6350 (13,990)
-3.1 m (-10 ft.)	17 940 (39,540)	17 940 (39,540)	14 550 (32,070)	13 350 (29,430)	11 430 (25,200)	9830 (21,670)	8310 (18,310)	7760 (17,090)		

Lift Capacity — 3756G Live-Heel Log Loader with 2.92-m (9 ft. 7 in.) LC undercarriage and 700-mm (28 in.) shoes; bare pin

Load Point Height	4.6 m (15 ft.)		6.1 m (20 ft.)		7.6 m (25 ft.)		9.1 m (30 ft.)		10.7 m (35 ft.)		12.2 m (40 ft.)	
	Over Front	Over Side	Over Front	Over Side	Over Front	Over Side	Over Front	Over Side	Over Front	Over Side	Over Front	Over Side
12.2 m (40 ft.)			15 250 (33,600)	14 760 (32,540)	12 400 (27,320)	10 630 (23,430)						
10.7 m (35 ft.)			14 080 (31,040)	14 080 (31,040)	12 750 (28,100)	10 450 (23,040)	10 650 (23,480)	7880 (17,370)				
9.1 m (30 ft.)			13 750 (30,300)	13 750 (30,300)	12 420 (27,380)	10 770 (23,740)	10 450 (23,040)	7700 (16,960)	8370 (18,440)	6180 (13,610)		
7.6 m (25 ft.)			14 020 (30,910)	14 020 (30,910)	12 660 (27,900)	10 800 (23,810)	10 630 (23,430)	7860 (17,320)	7960 (17,540)	5780 (12,750)		
6.1 m (20 ft.)			14 150 (31,190)	14 150 (31,190)	13 250 (29,200)	10 670 (23,510)	10 600 (23,360)	7830 (17,250)	8080 (17,810)	5900 (13,010)	6630 (14,610)	4830 (10,640)
4.6 m (15 ft.)			17 010 (37,480)	15 110 (33,300)	14 040 (30,940)	10 390 (22,910)	10 420 (22,970)	7660 (16,880)	8140 (17,940)	5960 (13,130)	6630 (14,610)	4820 (10,630)
3.1 m (10 ft.)			16 910 (37,270)	14 690 (32,380)	13 740 (30,290)	10 040 (22,120)	10 250 (22,580)	7500 (16,520)	8150 (17,970)	5970 (13,160)	6560 (14,450)	4750 (10,480)
1.5 m (5 ft.)			19 080 (42,050)	13 800 (30,410)	13 360 (29,440)	9680 (21,330)	10 140 (22,350)	7400 (16,310)	8020 (17,670)	5840 (12,880)	6470 (14,260)	4670 (10,300)
Ground Line	15 890 (35,030)	15 890 (35,030)	18 530 (40,830)	13 090 (28,840)	13 110 (28,900)	9460 (20,840)	9940 (21,910)	7210 (15,900)	7860 (17,320)	6690 (12,540)	6400 (14,100)	4610 (10,150)
-1.5 m (-5 ft.)	13 760 (30,330)	13 760 (30,330)	17 960 (39,580)	12 570 (27,710)	12 750 (28,090)	9110 (20,080)	9710 (21,410)	7000 (15,430)	7740 (17,050)	5580 (12,290)	6080 (13,410)	4590 (10,120)
-3.1 m (-10 ft.)	15 370 (33,880)	15 370 (33,880)	16 730 (36,880)	16 730 (36,880)	12 520 (27,600)	8910 (19,630)	9600 (21,160)	6890 (15,190)	7380 (16,270)	5550 (12,230)		
-4.6 m (-15 ft.)	16 790 (37,010)	16 790 (37,010)	13 240 (29,180)	12 230 (26,950)	10 270 (22,630)	8900 (19,610)	7490 (16,510)	6910 (15,240)				

Lift Capacity — 3756G Live-Heel Log Loader with 2.92-m (9 ft. 7 in.) LC undercarriage and 700-mm (28 in.) shoes; bare pin

Load Point Height	4.6 m (15 ft.)		6.1 m (20 ft.)		7.6 m (25 ft.)		9.1 m (30 ft.)		10.7 m (35 ft.)		12.2 m (40 ft.)	
	Over Front	Over Side	Over Front	Over Side	Over Front	Over Side	Over Front	Over Side	Over Front	Over Side	Over Front	Over Side
12.2 m (40 ft.)			15 250 (33,600)	15 160 (33,420)	12 400 (27,320)	10 900 (24,030)						
10.7 m (35 ft.)			14 080 (31,040)	14 080 (31,040)	12 750 (28,100)	10 730 (23,640)	11 250 (24,800)	8090 (17,830)				
9.1 m (30 ft.)			13 750 (30,300)	13 750 (30,300)	12 420 (27,380)	11 050 (24,350)	11 320 (24,950)	7900 (17,410)	9480 (20,900)	6340 (13,980)		
7.6 m (25 ft.)			14 020 (30,910)	14 020 (30,910)	12 660 (27,900)	11 080 (24,420)	11 300 (24,910)	8070 (17,780)	9060 (19,970)	5950 (13,110)		
6.1 m (20 ft.)			14 150 (31,190)	14 150 (31,190)	13 250 (29,200)	10 940 (24,120)	11 560 (25,480)	8040 (17,710)	9190 (20,250)	6070 (13,370)	7540 (16,610)	4960 (10,940)
4.6 m (15 ft.)			17 010 (37,480)	15 510 (34,180)	14 040 (30,940)	10 670 (23,510)	11 840 (26,100)	7870 (17,340)	9250 (20,390)	6130 (13,500)	7540 (16,610)	4960 (10,940)
3.1 m (10 ft.)			16 910 (37,270)	15 100 (33,270)	14 780 (32,580)	10 310 (22,730)	11 660 (25,700)	7700 (16,980)	9260 (20,420)	6140 (13,530)	7460 (16,440)	4900 (10,790)
1.5 m (5 ft.)			19 080 (42,050)	14 190 (31,280)	15 200 (33,510)	9950 (21,930)	11 560 (25,470)	7600 (16,760)	9120 (20,110)	6010 (13,240)	7370 (16,250)	4810 (10,600)
Ground Line	15 890 (35,030)	15 890 (35,030)	19 460 (42,900)	13 480 (29,700)	15 040 (33,150)	9720 (21,430)	11 350 (25,010)	7420 (16,350)	8960 (19,750)	5860 (12,910)	7300 (16,090)	4750 (10,460)
-1.5 m (-5 ft.)	13 760 (30,330)	13 760 (30,330)	18 730 (41,290)	12 960 (28,560)	14 580 (32,130)	9380 (20,670)	11 120 (24,500)	7210 (15,880)	8830 (19,470)	5740 (12,650)	6080 (13,410)	4730 (10,430)
-3.1 m (-10 ft.)	15 370 (33,880)	15 370 (33,880)	16 730 (36,880)	12 660 (27,910)	13 040 (28,750)	9170 (20,220)	10 150 (22,360)	7100 (15,640)	7380 (16,270)	5720 (12,600)		
-4.6 m (-15 ft.)	16 790 (37,010)	16 790 (37,010)	13 240 (29,180)	12 610 (27,800)	10 270 (22,630)	9170 (20,200)	7490 (16,510)	7120 (15,690)				



JOHN DEERE

JohnDeere.com/forestry

**TO FIND SUCCESS IN THE FOREST,
YOU CAN WAIT FOR THE PERFECT SET OF CONDITIONS.**
Or give yourself every advantage to create your own.
Productive machines. Useful insights. Dependable support.
A full set of solutions that only one partner can provide.

The obstacles to success are many. John Deere helps you
OUTRUN[™] THEM ALL.