

85G



Engine		85G	
Manufacturer and Model	Yanmar 4TNV98C-WHBW		
Non-Road Emission Standard	EPA Final Tier 4/EU Stage IV		
Net Power (ISO 9249)	42.4 kW (56.9 hp) at 2,000 rpm		
Cylinders	4		
Displacement	3.3 L (202 cu. in.)		
Aspiration	Natural		
Off-Level Capacity	70% (35 deg.)		
Cooling		Variable-speed fan; viscous clutch	
Powertrain		2-speed propel with automatic shift	
Maximum Travel Speed			
Low	3.1 km/h (1.9 mph)		
High	5.0 km/h (3.1 mph)		
Drawbar Pull	6650 kgf (14,661 lb.)		
Hydraulics		Open center, load sensing	
Main Pumps		3 variable-displacement axial-piston pumps	
Maximum Pump Flow	2 x 72 + 56 L/m (2 x 19 + 15 gpm)		
Pilot Pump		1 gear	
Maximum Rated Flow	20 L/m (5.3 gpm)		
System Relief Pressure	3900 kPa (566 psi)		
System Operating Pressure			
Implement Circuits	26 000 kPa (3,771 psi)		
Travel Circuits	31 400 kPa (4,554 psi)		
Swing Circuits	25 000 kPa (3,626 psi)		
Controls		Pilot levers, short stroke, low effort; hydraulic pilot controls with shutoff lever	
Cylinders		Heat-treated, chrome-plated, polished cylinder rods; hardened steel (replaceable bushings) pivot pins	
	<i>Bore</i>	<i>Rod Diameter</i>	<i>Stroke</i>
Boom (1)	115 mm (4.5 in.)	65 mm (2.6 in.)	885 mm (34.8 in.)
Arm (1)	95 mm (3.7 in.)	60 mm (2.4 in.)	900 mm (35.4 in.)
Bucket (1)	85 mm (3.3 in.)	55 mm (2.2 in.)	730 mm (28.7 in.)
Electrical		2 x 12 volt	
Batteries	2 x 450 CCA		
Battery Capacity	50 amp		
Alternator Rating	2 halogen: 1 mounted on boom and 1 mounted on frame		
Work Lights			
Undercarriage			
Rollers (each side)			
Carrier	1		
Track	5		
Shoes (each side)	40		
Track		Hydraulic	
Adjustment	Sealed and lubricated		
Chain			
Swing Mechanism		10.5 rpm	
Swing Speed	16 600 Nm (12,244 lb.-ft.)		
Swing Torque			
Boom Swing		60 deg.	
Left	60 deg.		
Right			



Ground Pressure		85G
450-mm (18 in.) Rubber Crawler Pads		41.5 kPa (6.0 psi)
450-mm (18 in.) Continuous Rubber Belt		41.4 kPa (6.0 psi)
450-mm (18 in.) Triple Semi-Grouser Shoes		41.3 kPa (6.0 psi)
600-mm (24 in.) Triple Semi-Grouser Shoes		31.7 kPa (4.6 psi)

Serviceability

Refill Capacities		
Fuel Tank		120 L (31.7 gal.)
Cooling System		9.7 L (2.6 gal.)
Engine Oil with Filter		12.3 L (3.2 gal.)
Hydraulic Tank		56 L (15 gal.)
Hydraulic System		103 L (27 gal.)
Propel Gearbox (each)		1.2 L (1.3 qt.)

Operating Weights

With 0.31-m³ (0.41 cu. yd.), 762-mm (30 in.), 313-kg (691 lb.) Bucket; 2.12-m (6 ft. 11 in.) Arm; 1408-kg (3,104 lb.) Counterweight; Full Fuel Tank; and 75-kg (165 lb.) Operator

2220-mm (7 ft. 3 in.) Blade and 450-mm (18 in.) Rubber Crawler Pads	8729 kg (19,244 lb.)
2220-mm (7 ft. 3 in.) Blade and 450-mm (18 in.) Triple Semi-Grouser Shoes	8677 kg (19,130 lb.)
2470-mm (8 ft. 1 in.) blade and 600-mm (24 in.) Triple Semi-Grouser Shoes	8874 kg (19,564 lb.)
2220-mm (7 ft. 3 in.) Blade and 450-mm (18 in.) Continuous Rubber Belt	8701 kg (19,182 lb.)

Optional Components

Undercarriage (with the following)	
450-mm (18 in.) Rubber Crawler Pads	2871 kg (6,329 lb.)
450-mm (18 in.) Continuous Rubber Belt	2843 kg (6,268 lb.)
450-mm (18 in.) Triple Semi-Grouser Shoes	2819 kg (6,215 lb.)
600-mm (24 in.) Triple Semi-Grouser Shoes	2970 kg (6,548 lb.)
1-Piece Boom (with arm cylinder)	
Arm with Bucket Cylinder and Linkage	
1.62 m (5 ft. 4 in.)	237 kg (522 lb.)
2.12 m (6 ft. 11 in.)	275 kg (606 lb.)
Boom Lift Cylinder	89 kg (196 lb.)
0.49-m ³ (0.64 cu. yd.), 1219-mm (48 in.) Ditching Bucket	330 kg (728 lb.)
Counterweight (standard)	1408 kg (3,104 lb.)

Operating Dimensions

	Arm Length 1.62 m (5 ft. 4 in.)	Arm Length 2.12 m (6 ft. 11 in.)
Arm Digging Force (ISO)	35.5 kN (7,981 lb.)	30.7 kN (6,902 lb.)
Bucket Digging Force (ISO)	46.6 kN (10,476 lb.)	46.6 kN (10,476 lb.)
A Maximum Reach	7.21 m (23 ft. 8 in.)	7.70 m (25 ft. 3 in.)
A' Maximum Reach at Ground Level	7.05 m (23 ft. 2 in.)	7.55 m (24 ft. 9 in.)
B Maximum Digging Depth	3.99 m (13 ft. 1 in.)	4.51 m (14 ft. 10 in.)
B' Maximum Digging Depth at 2.44-m (8 ft.) Flat Bottom	3.62 m (11 ft. 11 in.)	4.20 m (13 ft. 9 in.)
C Maximum Cutting Height	6.79 m (22 ft. 3 in.)	7.14 m (23 ft. 5 in.)
D Maximum Dumping Height	4.77 m (15 ft. 8 in.)	5.08 m (16 ft. 8 in.)
E Minimum Swing Radius	2.74 m (9 ft. 0 in.)	2.89 m (9 ft. 6 in.)
F Maximum Vertical Wall	3.47 m (11 ft. 5 in.)	4.05 m (13 ft. 3 in.)
G Tail Swing Radius	1.49 m (4 ft. 11 in.)	1.49 m (4 ft. 11 in.)

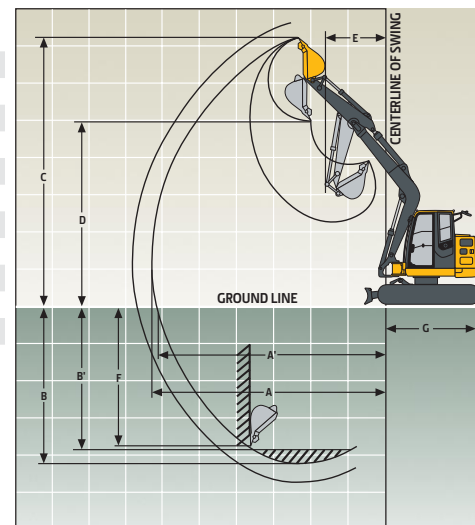

Machine Dimensions

85G

	Arm Length	Arm Length
A Overall Length	1.62 m (5 ft. 4 in.)	2.12 m (6 ft. 11 in.)
B Overall Height	6.64 m (21 ft. 9 in.)	6.82 m (22 ft. 5 in.)
With 450-mm (18 in.) Rubber Crawler Pads	2.61 m (8 ft. 7 in.)	
With Steel Shoes	2.53 m (8 ft. 4 in.)	
C Undercarriage Width		
With 450-mm (18 in.) Shoes	2.20 m (7 ft. 3 in.)	
With 600-mm (24 in.) Shoes	2.47 m (8 ft. 1 in.)	
D Rear-End Length/Swing Radius	1.49 m (4 ft. 11 in.)	
E Distance Between Idler/Sprocket Centerline	2.29 m (7 ft. 6 in.)	
F Undercarriage Length	2.92 m (9 ft. 7 in.)	
G Counterweight Clearance	0.72 m (28 in.)	
H Cab Height	2.53 m (8 ft. 4 in.)	
I Ground Clearance	360 mm (14 in.)	
J Upperstructure Width	2.32 m (7 ft. 7 in.)	
K Gauge Width	1.87 m (6 ft. 2 in.)	
L Blade Lift Height	340 mm (13 in.)	
Blade Height	460 mm (18 in.)	
Blade Width		
With 450-mm (18 in.) Shoes	2200 mm (7 ft. 3 in.)	
With 600-mm (24 in.) Shoes	2470 mm (8 ft. 1 in.)	
M Blade Cut Below Grade	320 mm (13 in.)	
N Blade Lift Angle	26 deg.	
O Track Width		
With 450-mm (18 in.) Shoes	0.45 m (18 in.)	
With 600-mm (24 in.) Shoes	0.60 m (24 in.)	

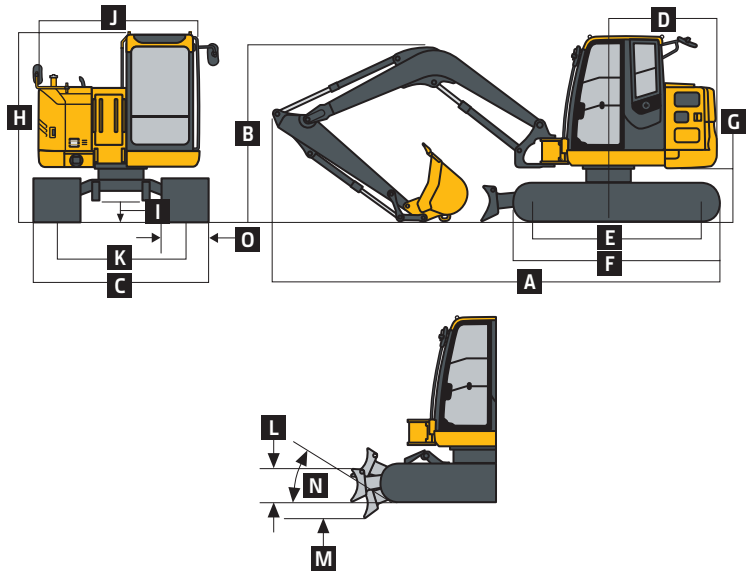

Lift Capacities

Boldface type indicates hydraulically limited capacities; lightface type indicates stability-limited capacities, in kg (lb.). Ratings are at bucket lift hook, using standard counterweight, situated on firm, level, uniform supporting surface. Total load includes weight of cables, hook, etc. Figures do not exceed 87% of hydraulic capacity or 75% of weight needed to tip machine. All lift capacities are based on ISO 10567.

Load Point Height	1.5 m (5 ft.)		3.0 m (10 ft.)		4.5 m (15 ft.)		6.0 m (20 ft.)	
Horizontal Distance from Centerline of Rotation	Over Front	Over Side	Over Front	Over Side	Over Front	Over Side	Over Front	Over Side
<i>With 3.67-m (12 ft. 2 in.) boom, 1.62-m (5 ft. 4 in.) arm, 0.28-m³ (0.37 cu. yd.) bucket, 450-mm (18 in.) rubber pads, and 2200-mm (7 ft. 3 in.) blade</i>								
3.0 m (10 ft.)			3432 (7,567)	2887 (6,365)	2312 (5,096)	1580 (3,484)		
1.5 m (5 ft.)					2819 (6,215)	1481 (3,265)	2078 (4,582)	992 (2,188)
Ground Line			2434 (5,367)	2434 (5,367)	3047 (6,717)	1416 (3,121)		
-1.5 m (-5 ft.)			4279 (9,433)	2503 (5,518)	2711 (5,976)	1410 (3,109)		
<i>With 3.67-m (12 ft. 2 in.) boom, 2.12-m (6 ft. 11 in.) arm, 0.28-m³ (0.37 cu. yd.) bucket, 450-mm (18 in.) rubber pads, and 2200-mm (7 ft. 3 in.) blade</i>								
4.5 m (15 ft.)					1735 (3,825)	1656 (3,651)		
3.0 m (10 ft.)					2044 (4,506)	1597 (3,521)	1809 (3,988)	1022 (2,253)
1.5 m (5 ft.)					2619 (5,773)	1488 (3,280)	1968 (4,339)	986 (2,174)
Ground Line			2577 (5,682)	2445 (5,391)	2992 (6,597)	1403 (3,092)	2069 (4,561)	952 (2,098)
-1.5 m (-5 ft.)	2683 (5,914)	2683 (5,914)	4770 (10,516)	2448 (5,397)	2868 (6,322)	1377 (3,036)		
-3.0 m (-10 ft.)			3130 (7,012)	3130 (5,560)				
<i>With 3.67-m (12 ft. 2 in.) boom, 1.62-m (5 ft. 4 in.) arm, 0.28-m³ (0.37 cu. yd.) bucket, 600-mm (24 in.) shoes, and 2470-mm (8 ft. 1 in.) blade</i>								
3.0 m (10 ft.)			3432 (7,567)	2927 (6,453)	2312 (5,096)	1603 (3,535)		
1.5 m (5 ft.)					2819 (6,215)	1505 (3,317)	2078 (4,582)	1009 (2,224)
Ground Line			2434 (5,367)	2434 (5,367)	3047 (6,717)	1439 (3,172)		
-1.5 m (-5 ft.)			4279 (9,433)	2543 (5,606)	2711 (5,976)	1433 (3,160)		

Lift Capacities (continued)

85G

Boldface type indicates hydraulically limited capacities; lightface type indicates stability-limited capacities, in kg (lb.). Ratings are at bucket lift hook, using standard counterweight, situated on firm, level, uniform supporting surface. Total load includes weight of cables, hook, etc. Figures do not exceed 87% of hydraulic capacity or 75% of weight needed to tip machine. All lift capacities are based on ISO 10567.

Load Point Height	1.5 m (5 ft.)		3.0 m (10 ft.)		4.5 m (15 ft.)		6.0 m (20 ft.)	
Horizontal Distance from Centerline of Rotation	Over Front	Over Side	Over Front	Over Side	Over Front	Over Side	Over Front	Over Side
<i>With 3.67-m (12 ft. 2 in.) boom, 2.12-m (6 ft. 11 in.) arm, 0.28-m³ (0.37 cu. yd.) bucket, 600-mm (24 in.) shoes, and 2470-mm (8 ft. 1 in.) blade</i>								
4.5 m (15 ft.)					1735 (3,825)	1679 (3,702)		
3.0 m (10 ft.)					2044 (4,506)	1620 (3,572)	1809 (3,988)	1038 (2,289)
1.5 m (5 ft.)					2619 (5,773)	1511 (3,332)	1968 (4,339)	1002 (2,210)
Ground Line			2577 (5,682)	2485 (5,479)	2992 (6,597)	1426 (3,143)	2069 (4,561)	968 (2,134)
-1.5 m (-5 ft.)	2683 (5,914)	2683 (5,914)	4770 (10,516)	2488 (5,485)	2868 (6,322)	1400 (3,087)		
-3.0 m (-10 ft.)			3130 (7,012)	3130 (5,647)				
<i>With 3.67-m (12 ft. 2 in.) boom, 2.12-m (6 ft. 11 in.) arm, less bucket, 450-mm (18 in.) continuous rubber belt, and 2200-mm (7 ft. 3 in.) blade</i>								
4.5 m (15 ft.)					1728 (3,810)	1579 (3,480)		
3.0 m (10 ft.)					2050 (4,520)	1520 (3,350)	1805 (3,980)	971 (2,140)
1.5 m (5 ft.)					2626 (5,790)	1411 (3,110)	1969 (4,340)	934 (2,060)
Ground Line			2595 (5,720)	2309 (5,090)	2994 (6,600)	1329 (2,930)	2068 (4,560)	903 (1,990)
-1.5 m (-5 ft.)	2708 (5,970)	2708 (5,970)	4758 (10,490)	2309 (5,090)	2862 (6,310)	1306 (2,880)		
-3.0 m (-10 ft.)			3139 (6,920)	2386 (5,260)				

Buckets

A full line of buckets is offered to meet a wide variety of applications. Replaceable cutting edges are available through John Deere Parts. Optional side cutters add 150 mm (6 in.) to bucket widths.

Type Bucket	Bucket Width		Bucket Capacity		Bucket Weight		Bucket Dig Force (ISO)		Arm Dig Force (ISO)		Arm Dig Force (ISO)		Bucket Tip Radius		Number of Teeth
	mm	in.	m ³	cu. yd.	kg	lb.	kN	lb.	1.62 m (5 ft. 4 in.)	2.12 m (6 ft. 11 in.)	kN	lb.	mm	in.	
Heavy Duty	610	24	0.31	0.40	287	633	54	12,061	38	8,491	32	7,162	1087	42.80	5
	762	30	0.41	0.53	333	735	54	12,061	38	8,491	32	7,162	1087	42.80	6
	914	36	0.50	0.66	380	837	54	12,061	38	8,491	32	7,162	1087	42.80	7
Ditching	1219	48	0.49	0.64	330	727	64	14,344	40	8,911	33	7,473	907	35.69	0

Bucket Selection Guide*

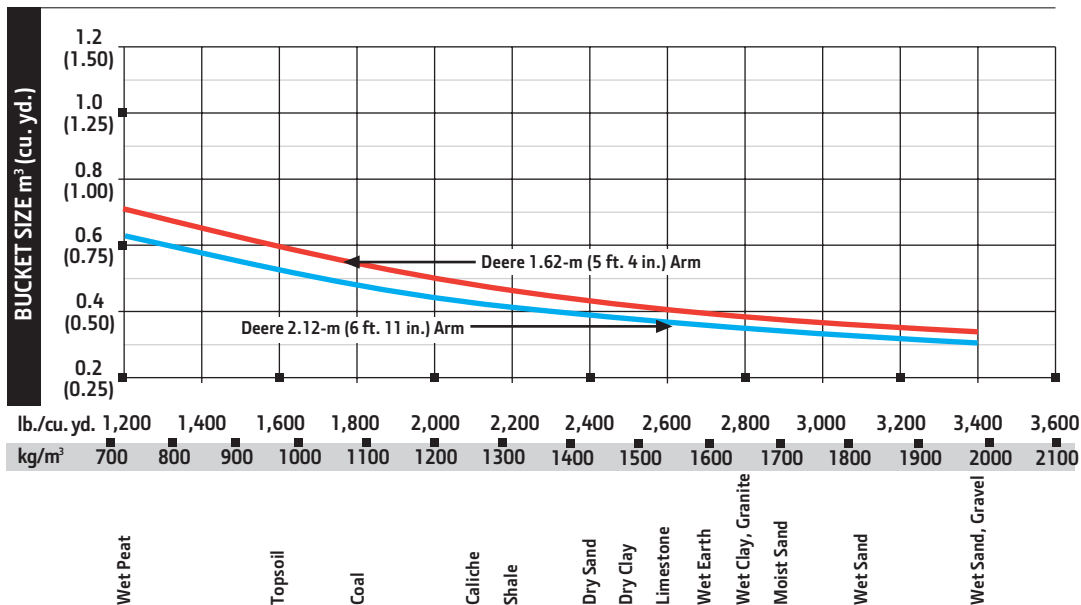

*Contact your John Deere dealer for optimum bucket and attachment selections. These recommendations are for general conditions and average use. Does not include optional equipment such as thumbs or couplers. Larger buckets may be possible when using light materials, for flat and level operations, less compacted materials, and volume loading applications such as mass-excavation applications in ideal conditions. Smaller buckets are recommended for adverse conditions such as off-level applications, rocks, and uneven surfaces. Bucket capacity indicated is SAE heaped.