

G-SERIES COMPACT EXCAVATORS

35G/50G/60G



JOHN DEERE





Make a bigger impact with our compacts.

Looking to get more out of your “mini ex”? Make your next compact one of our G-Series. Inspired by input from equipment owners and operators like you, these nimble machines are loaded with customer-driven enhancements. Such as a more spacious cab with a wider entryway. Larger expanse of glass for unsurpassed visibility. Fuel-saving auto-shutdown and power/economy work modes. Ultra-reliable Final Tier 4 (FT4)/Stage IV engines. Plus three large service doors allow wide-open access to maintenance items such as side-by-side coolers for simplified core clean-out. Get a G-Series and get the same power, productivity, reliability, and comfort you’ve come to expect from our compacts — in an even more operator-friendly package.

Ultra-reliable, fuel-efficient diesels meet EPA FT4/EU Stage IV emission standards. Power/economy modes optimize power for digging applications and significantly improve fuel efficiency.

With large entryways and virtually unrestricted sightlines, the G-Series' spacious operator stations deliver all the comfort, convenience, and visibility an operator needs. And then some.

Zero- and reduced-tail-swing designs make these compacts extra maneuverable and plenty productive in places with tight spaces.



Key specifications	35G	50G	60G
Net power (FT4/Stage IV)	17.4 kW (23.3 hp)	26.8 kW (35.9 hp)	39.6 kW (53.0 hp)
Maximum Digging Reach	5.21 m (17 ft. 1 in.)	5.96 m (19 ft. 7 in.)	6.23 m (20 ft. 5 in.)
Maximum Digging Depth	3.06 m (10 ft. 0 in.)	3.53 m (11 ft. 7 in.)	3.77 m (12 ft. 4 in.)
Operating Weight	3520 kg (7,760 lb.)	4790 kg (10,560 lb.)	6145 kg (13,547 lb.)

A high-angle, close-up photograph of the operator's station inside an excavator. The view shows a grey fabric seat, a white control panel with various levers and buttons, and a black rubber floor mat. A gear shift lever is prominent in the center. The background shows the dark interior of the cab with some warning labels, including one that says "DANGER".

More comfortable interiors provide for a more productive day.

Step aboard one of our excavators and you'll discover that compacts don't have to be uncomfortable. The G-Series' spacious operator stations won't cramp an operator's style. Seat, pedals, and controls are positioned to accommodate bigger operators. And virtually unobstructed visibility provides a commanding view of the work at hand and jobsite around you. For year-round comfort and increased productivity, add a heated and air-conditioned cab. Just like the canopy-equipped models, visibility and roominess are second to none.

Swing boom and foldable travel pedals are positioned where they're easy to operate, yet allow plenty of foot room.

Auto-idle automatically reduces engine speed when hydraulics aren't in use. Auto-shutdown further preserves every precious drop of fuel.

Convenient 12-volt port powers cell phones and other electronic devices. There's also a large cup holder and seatback compartment for documents.

Redesigned cab's 50-mm (2 in.) wider, 150-mm (6 in.) taller front glass and single-hinge door provide unsurpassed all-around visibility.

Spacious operator stations have wide entryways, making entrance and exit easier than ever. Flat, skid-resistant floor mat removes easily for clean-out.

No operator activation required for high-speed travel. Track speeds automatically slow to low whenever the travel motors encounter a heavier load. Includes a console-mounted, low-speed lock switch.

Noise-reducing muffler (35G) and after-treatment device (50G/60G), plus isochronous high-idle speed, help keep things noticeably quiet. Rubber cab mounts further isolate the operator from noise and vibration to help reduce fatigue.

1. Enhanced monitor provides vital operating info at a glance and fingertip control of several functions, including auto-shutdown, power/economy modes, and auto exhaust-filter cleaning. Plus two trip meters let you track engine oil and hydraulic oil changes, or jobsite hours.

2. Go from backhoe- to excavator-style controls with just a twist of your wrist. Control-pattern selector valve is conveniently located in a compartment beneath the seat.

3. Ergonomic short-throw pilot-control levers provide smooth, predictable low-effort fingertip operation.

4. Automatic, high-velocity bi-level climate-control system with automotive-style adjustable louvers helps keep the glass clear and the cab comfortable.

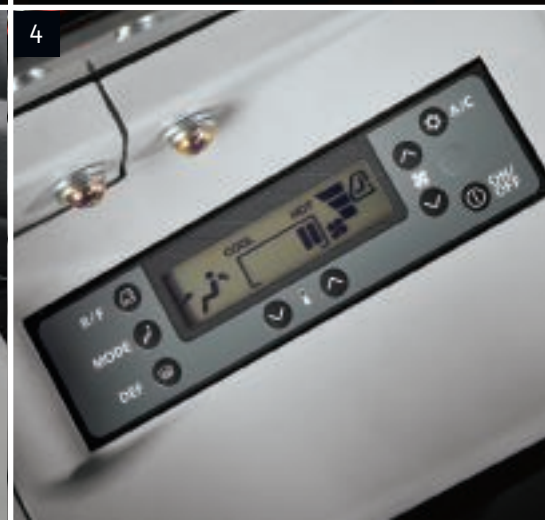



Power/economy work modes allow you to match engine speed to the application. Select power mode and get the higher engine speeds needed for most general digging work. For lighter digging demands, economy mode reduces engine speed and noise, while improving fuel efficiency.

Large diesels deliver impressive torque for more pull-through power when the going gets tough.

35G employs the same hydraulic system as the 50G, enabling it to run at a lower rpm for reduced noise and fuel consumption without sacrificing power.

G-Series Compacts transport easily between jobsites, making them perfect for “dig-and-go” jobs. Enlarged tie-down openings allow you to secure these machines using the same-size chains used on your larger equipment.



Their possibilities are almost endless.

Sure, their compact sizes and reduced-tail-swing design enable these small-but-mighty machines to specialize in close-quarters work. But that's not the only reason to run one. Their highly fuel-efficient, direct-injected diesels meet Final Tier 4/Stage IV emission standards and are noticeably quiet so you can put them to work almost anywhere, any time. Standard-equipped with backfill blade, mechanical quick-coupler, and auxiliary hydraulics, plus any of the many optional Worksite Pro™ attachments, they can make a sizeable impact on your productivity. And profitability.

1. Although they won't replace a grading tractor, their standard blades enable these excavators to fill-in quite capably.
2. Choose the tracks that are best for the way you work. Rubber tracks traverse virtually any terrain, including paved surfaces. Steel tracks and steel tracks with rubber pads are also available. Optional rubber grousers combine work-anywhere flexibility with steel-track serviceability.
3. Why allow obstacles to dictate how you work? Get a G-Series Compact and put its independent-swing boom and 360-degree rotation to good use.
4. Virtually unrestricted visibility, precise feel, and smooth control make our compacts ideal for excavating around existing utilities.
5. Truck sideboards are no problem for these compacts. Lift height and reach are plentiful, making truck loading easy.



Arm yourself for even more productivity.

Want to do even more with these highly versatile compacts? Add any of the many available buckets and Worksite Pro attachments to your equipment arsenal and watch utilization take off. G-Series Compacts arrive attachment-ready with boom-mounted auxiliary hydraulic lines and a quick-coupler that let you go from bucket to breaker to whatever, quickly and easily. See your John Deere dealer today for details and financing options.

1. Standard quick-coupler-equipped, boom-mounted auxiliary hydraulic lines make attachment hookup a snap.
2. Wedge-style coupler enables quick changes and accepts a wide variety of buckets and attachments, such as breakers and augers.
3. Worksite Pro planetary augers can be equipped with rock, heavy-duty, standard, and tree/shrub bits.
4. Optional 35G and 50G backfill blade angles 25 degrees, right or left, at the touch of a button.
5. Bust through blacktop, concrete, or other solid surfaces with a Worksite Pro breaker. Front cab screens are available to help prevent glass damage.





Add a top clamp for thumb-like dexterity that comes in handy when handling cumbersome objects or cleaning up jobsites.

Return-flow selector valve accommodates both one- and two-way hydraulic-driven attachments. Make changes with just a twist of the wrist.

Worksite Pro breakers and augers also work on other John Deere compact machines, so you can make the most of your investment.

Ditch-cleaning buckets from 762-to-1067-mm (30 to 42 in.) wide handle loose or mucky materials.

Need more digging depth or reach? Choose the long-arm/heavy-counterweight option that provides an increase in both.

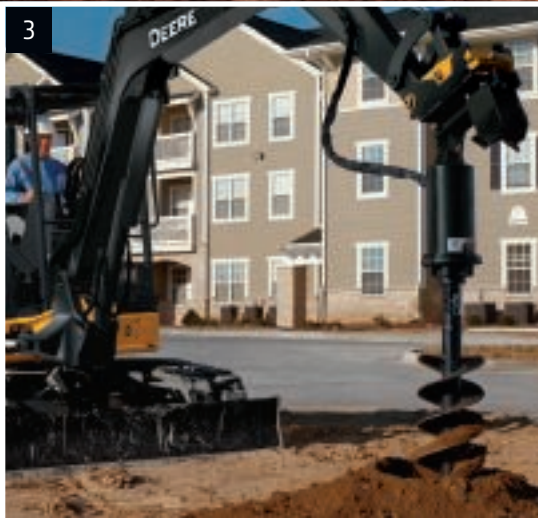

3



4

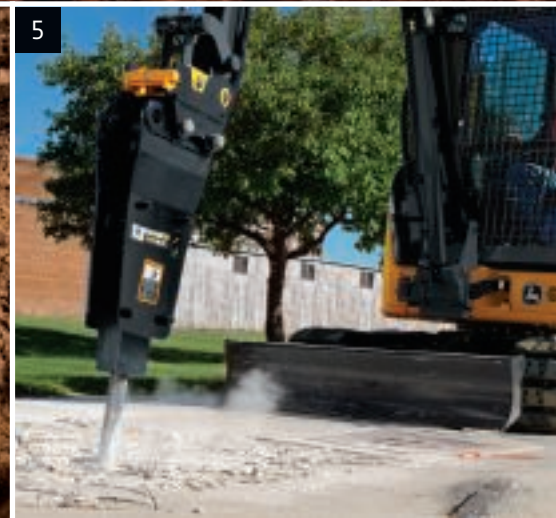

5

A close-up photograph of a yellow Deere excavator bucket dumping a large amount of brown soil. The bucket is tilted, and the soil is falling in a thick stream. In the background, there is a construction site with concrete walls, scaffolding, and a red safety net. The lighting is bright, suggesting a sunny day.

Nothing runs like a Deere, because nothing is built like one.

Don't let their compact statures fool you. Like their larger G-Series siblings, the 35G, 50G, and 60G are exceptionally durable. And for good reason — they share many of the same uptime-boosting features such as powdered-metal oil-impregnated boom, arm, and bucket bushings. Rigid reinforced D-channel side frames. And heavy-duty X-frames. When you know how they're built, you'll run a Deere.



1. Single-pin swing-post increases boom stiffness, enhancing the structural integrity of digging components. Wear-resistant hoses are routed for protection and Cordura®-wrapped where exposed.

2. Heavy-duty shields deflect material and impacts, protecting the boom/blade cylinders and drive motors.

3. Rubber tracks' unique steel cores resist cracking. Large-diameter drive sprockets and track idlers further increase undercarriage durability.

4. Heavy-duty X-frame provides a solid, stable platform that resists material and dirt buildup.

O-ring face-seal hydraulic fittings virtually eliminate aggravating and costly oil leaks.

Oil-impregnated bushings enhance durability and extend grease intervals to 500 hours for the arm-and-boom joint, and 100 hours for the bucket.

Rigid, reinforced D-channel side frames resist impact, providing maximum cab and component protection.

Self-priming diesel helps you get back up and running quickly should you ever run out of fuel.

Wet-disc swing brake provides long-term maintenance-free performance.

To help prevent accidental machine movement, a spring-applied, hydraulically released park brake automatically engages when a control lever is released.

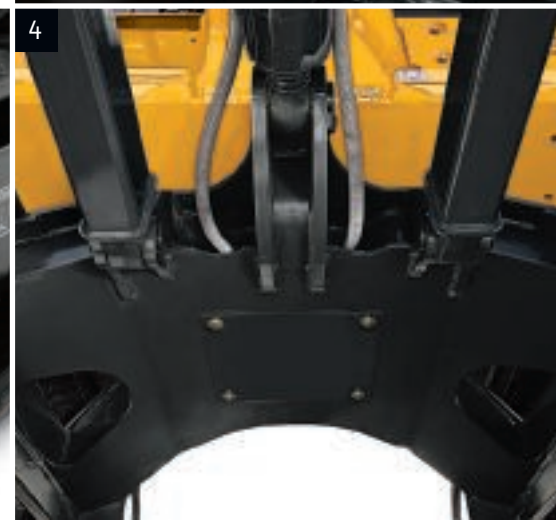

Won't bust your tail or your budget.

If there's a way to increase uptime, reduce your daily operating costs, and simplify maintenance, we've implemented it in the G-Series. Extended hydraulic and engine oil-change intervals reduce downtime and expense. Daily checks are done through a steel rear door that slides up and out of the way. If necessary, the operator station tilts forward, providing quick, wide-open component access. And of course, industry-leading parts and service are just as easily accessible at more than 1,300 John Deere locations coast to coast. Easy to work with, easy to maintain — that's our G-Series.

1. Vertical spin-on filters allow quick and clean changes. Extended engine and hydraulic oil-change intervals let you work longer.
2. Hinged door provides wide-open access to the side-by-side oil cooler and radiator for easier core clean-out.
3. Operator station tilts forward 50 degrees, simplifying access to the swing motor, hydraulic control valve, engine starter motor, and alternator.
4. Routine checks such as engine oil level are quickly accomplished from ground level. Convenient lube/maintenance chart helps ensure that nothing gets overlooked.
5. Hydraulic fluid sight gauge and see-through coolant reservoir let you quickly check levels at a glance.
6. A simple grease gun and a wrench are all it takes to quickly maintain proper track tension.





The EPA FT4/EU Stage IV technology in our excavators is simple, fuel efficient, fully integrated, and fully supported. In the 50G and 60G, it employs field-proven cooled exhaust gas recirculation (EGR) for reducing NO_x, and a diesel particulate filter (DPF) and diesel oxidation catalyst (DOC) to reduce particulate matter. The 35G doesn't require an after-treatment system to meet EPA requirements.

Seamless DPF cleaning happens automatically without impacting machine productivity. Minimum service interval is 3,000 hours and can be done by your John Deere dealer.

Fuel-sipping diesels, auto-idle, and economy work mode help conserve precious fuel.

Large fuel tanks and 500- and 2,000-hour engine and hydraulic oil-service and 500-hour greasing intervals enable these excavators to work longer between stops for scheduled service.

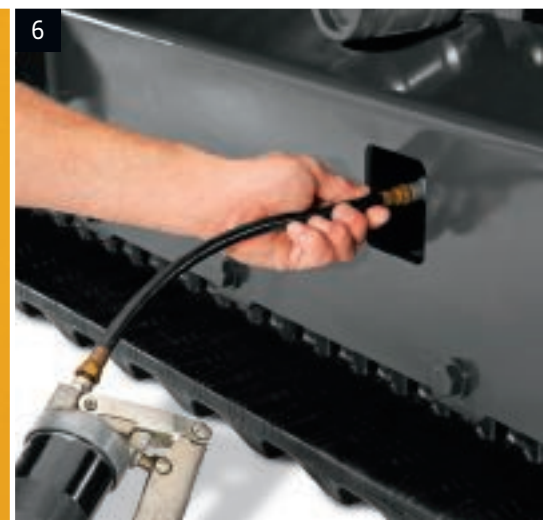
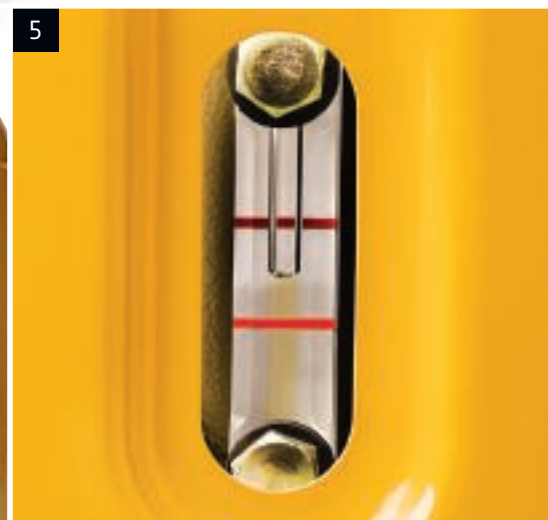

35G



Engine		35G			
Manufacturer and Model	Yanmar 3TNV88F				
Non-Road Emission Standard	EPA Final Tier 4/EU Stage IV				
Displacement	1.642 L (100.2 cu. in.)				
Net Power (ISO 9249)	17.4 kW (23.3 hp) at 2,400 rpm				
Powertrain					
Each track independently driven by hydrostatic axial-piston motor connected to 2-stage planetary gear-reduction box					
Maximum Travel Speed					
Low	2.8 km/h (1.7 mph)				
High	4.3 km/h (2.7 mph)				
Hydraulics					
Open center with 2 variable-displacement pumps and 1 fixed-gear pump					
Pump Flow					
Piston	2 x 38.4 L/m (2 x 10.1 gpm)				
Gear	22.8 L/m (6.0 gpm)				
Auxiliary Flow	61.2 L/m (16.2 gpm)				
Controls	2 hydraulic pilot-operated controls for boom, arm, bucket, swing, boom swing, travel, and auxiliary functions				
Electrical					
Alternator Rating	55 amp				
Work Lights	2 halogen: 1 mounted on operator's station and 1 mounted on boom				
Undercarriage					
Track, Rubber	300 mm (12 in.)				
Ground Pressure					
	1315-mm (4 ft. 4 in.)				
	<i>Standard Arm, Canopy, and Standard Counterweight</i>	<i>1315-mm (4 ft. 4 in.) Standard Arm, Cab, and Standard Counterweight</i>	<i>1715-mm (5 ft. 8 in.) Long Arm, Canopy, and Extra Counterweight</i>	<i>1715-mm (5 ft. 8 in.) Long Arm, Cab, and Extra Counterweight</i>	
With Rubber Track	32.0 kPa (4.6 psi)	33.0 kPa (4.8 psi)	33.7 kPa (4.9 psi)	35.2 kPa (5.1 psi)	
Upperstructure					
Swing Speed	9.0 rpm				
Independent Swing Boom	<i>Canopy</i>	<i>Cab</i>			
Left	72 deg.	62 deg.			
Right	62 deg.	62 deg.			
Swing Brake	Spring applied, hydraulically released, automatic, disc type				
Serviceability					
Refill Capacities					
Fuel Tank	42 L (11.1 gal.)				
Cooling System	5.0 L (5.3 qt.)				
Engine Oil with Filter	7.2 L (7.6 qt.)				
Hydraulic Tank	32 L (8.5 gal.)				
Operating Weights					
	1315-mm (4 ft. 4 in.)				
	<i>Standard Arm, Canopy, and Standard Counterweight</i>	<i>1315-mm (4 ft. 4 in.) Standard Arm, Cab, and Standard Counterweight</i>	<i>1715-mm (5 ft. 8 in.) Long Arm, Canopy, and Extra Counterweight</i>	<i>1715-mm (5 ft. 8 in.) Long Arm, Cab, and Extra Counterweight</i>	
With Full Fuel Tank and 79-kg (175 lb.) Operator	3520 kg (7,760 lb.)	3690 kg (8,135 lb.)	3783 kg (8,340 lb.)	3953 kg (8,715 lb.)	
Optional Angle Blade	296 kg (653 lb.)				
Counterweight					
Standard	540 kg (1,190 lb.)				
Additional	240 kg (529 lb.)				



Operating Dimensions		35G			
		1315-mm (4 ft. 4 in.) Standard Arm and Canopy	1715-mm (5 ft. 8 in.) Long Arm and Canopy	1315-mm (4 ft. 4 in.) Standard Arm and Cab	1715-mm (5 ft. 8 in.) Long Arm and Cab
A	Maximum Cutting Height	4.87 m (16 ft. 0 in.)	4.95 m (16 ft. 3 in.)	4.70 m (15 ft. 5 in.)	4.74 m (15 ft. 7 in.)
B	Maximum Dumping Height	3.46 m (11 ft. 4 in.)	3.57 m (11 ft. 9 in.)	3.31 m (10 ft. 10 in.)	3.39 m (11 ft. 1 in.)
C	Maximum Digging Depth	3.06 m (10 ft. 0 in.)	3.46 m (11 ft. 4 in.)	3.06 m (10 ft. 0 in.)	3.46 m (11 ft. 4 in.)
D	Maximum Digging Reach	5.21 m (17 ft. 1 in.)	5.52 m (18 ft. 1 in.)	5.21 m (17 ft. 1 in.)	5.52 m (18 ft. 1 in.)
E	Minimum Front Swing Radius	2.08 m (6 ft. 10 in.)	2.19 m (7 ft. 2 in.)	2.24 m (7 ft. 4 in.)	2.30 m (7 ft. 7 in.)
F	Transport Length	4.64 m (15 ft. 3 in.)	4.75 m (15 ft. 7 in.)	4.64 m (15 ft. 3 in.)	4.75 m (15 ft. 7 in.)
Digging Force (ISO)					
	Arm	19.0 kN (4,277 lb.)	16.9 kN (3,792 lb.)	19.0 kN (4,277 lb.)	16.9 kN (3,792 lb.)
	Bucket	27.1 kN (6,085 lb.)	27.1 kN (6,085 lb.)	27.1 kN (6,085 lb.)	27.1 kN (6,085 lb.)

Machine Dimensions		
G	Upperstructure Width	1.55 m (5 ft. 1 in.)
H	Overall Height	
	Canopy	2.48 m (8 ft. 2 in.)
	Cab	2.48 m (8 ft. 2 in.)
I	Track Width	300 mm (12 in.)
J	Undercarriage Width	1.74 m (5 ft. 9 in.)
K	Ground Clearance	280 mm (11 in.)
L	Tail Swing Radius	
	With Standard Arm	870 mm (34 in.)
	With Long Arm and Extra Counterweight	980 mm (39 in.)
M	Engine Cover Height	1.53 m (5 ft. 0 in.)
N	Maximum Blade Lift Above Ground	360 mm (14.2 in.)
O	Maximum Blade Drop Below Ground	400 mm (15.7 in.)
Blade		
	Width	1.74 m (5 ft. 9 in.)
	Height	373 mm (14.7 in.)
P	Sprocket Center to Idler Center	1.66 m (5 ft. 5 in.)
Q	Undercarriage Length	2.11 m (6 ft. 11 in.)
R	Counterweight Clearance	550 mm (22 in.)

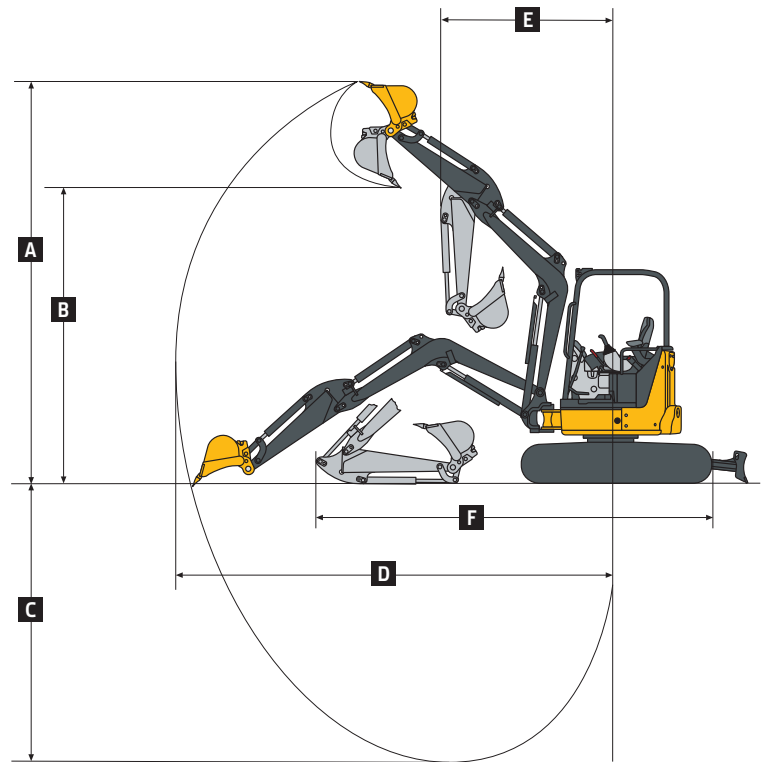
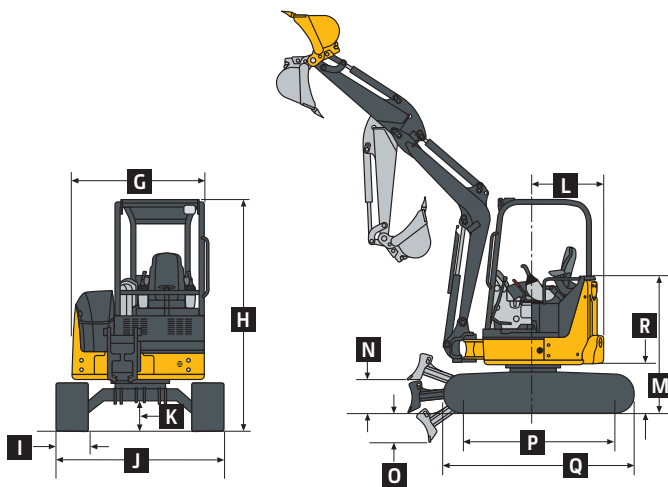

Lift Capacities									
Ground Level at 3.05-m (10 ft.) Radius		Canopy and Standard Counterweight		Canopy and Extra Counterweight		Cab and Standard Counterweight		Cab and Extra Counterweight	
Arm		Over Front*	Over Side	Over Front*	Over Side	Over Front*	Over Side	Over Front*	Over Side
	1315-mm (4 ft. 4 in.) Standard	1568 kg (3,453 lb.)	641 kg (1,412 lb.)	1568 kg (3,453 lb.)	765 kg (1,686 lb.)	1568 kg (3,453 lb.)	684 kg (1,506 lb.)	1568 kg (3,453 lb.)	808 kg (1,780 lb.)
	1715-mm (5 ft. 8 in.) Long	1501 kg (3,307 lb.)	630 kg (1,388 lb.)	1501 kg (3,307 lb.)	755 kg (1,662 lb.)	1501 kg (3,307 lb.)	672 kg (1,481 lb.)	1501 kg (3,307 lb.)	797 kg (1,756 lb.)

*Blade down (limited by hydraulics).

50G



Engine		50G			
Manufacturer and Model	Yanmar 4TNV88C				
Non-Road Emission Standard	EPA Final Tier 4/EU Stage IV				
Displacement	2.19 L (134 cu. in.)				
Net Power (ISO 9249)	26.8 kW (35.9 hp) at 2,400 rpm				
Powertrain		Each track independently driven by hydrostatic axial-piston motor connected to 2-stage planetary gear-reduction box			
Maximum Travel Speed					
Low	2.5 km/h (1.6 mph)				
High	4.2 km/h (2.6 mph)				
Hydraulics					
Closed-center load sensing with 1 variable-displacement pump					
Pump Flow	120.0 L/m (31.7 gpm)				
Auxiliary Flow	87.4 L/m (23.1 gpm)				
Controls	Hydraulic pilot-operated controls for boom, arm, bucket, swing, boom swing, blade, travel, and auxiliary functions				
Electrical					
Alternator Rating	55 amp				
Work Lights	2 halogen: 1 mounted on operator's station and 1 mounted on boom				
Undercarriage					
Track, Rubber	400 mm (16 in.)				
Ground Pressure		1380-mm (4 ft. 6 in.)			
	<i>Standard Arm, Canopy, and Standard Counterweight</i>	<i>1380-mm (4 ft. 6 in.) Standard Arm, Cab, and Standard Counterweight</i>	<i>1690-mm (5 ft. 7 in.) Long Arm, Canopy, and Extra Counterweight</i>	<i>1690-mm (5 ft. 7 in.) Long Arm, Cab, and Extra Counterweight</i>	
With Rubber Track	26.9 kPa (3.90 psi)	28.3 kPa (4.10 psi)	28.8 kPa (4.17 psi)	29.5 kPa (4.28 psi)	
Upperstructure					
Swing Speed	9.0 rpm				
Independent Swing Boom					
Left	80 deg.				
Right	60 deg.				
Swing Brake	Spring applied, hydraulically released, automatic, disc type				
Serviceability					
Refill Capacities					
Fuel Tank	70 L (18.5 gal.)				
Cooling System	5.0 L (5.3 qt.)				
Engine Oil with Filter	8.6 L (9.1 qt.)				
Hydraulic Tank	56 L (14.8 gal.)				
Operating Weights		1380-mm (4 ft. 6 in.)			
	<i>Standard Arm, Canopy, and Standard Counterweight</i>	<i>1380-mm (4 ft. 6 in.) Standard Arm, Cab, and Standard Counterweight</i>	<i>1690-mm (5 ft. 7 in.) Long Arm, Canopy, and Extra Counterweight</i>	<i>1690-mm (5 ft. 7 in.) Long Arm, Cab, and Extra Counterweight</i>	
With 400-mm (16 in.) Rubber Track, Straight Blade, Full Fuel Tank, and 79-kg (175 lb.) Operator	4790 kg (10,560 lb.)	4920 kg (10,847 lb.)	5018 kg (11,063 lb.)	5148 kg (11,349 lb.)	
Optional Angle Blade	409 kg (902 lb.)				
Counterweight					
Standard	700 kg (1,543 lb.)				
Additional	200 kg (441 lb.)				



Operating Dimensions		50G			
		1380-mm (4 ft. 6 in.) Standard Arm and Canopy	1690-mm (5 ft. 7 in.) Long Arm and Canopy	1380-mm (4 ft. 6 in.) Standard Arm and Cab	1690-mm (5 ft. 7 in.) Long Arm and Cab
A	Maximum Cutting Height	5.75 m (18 ft. 10 in.)	6.00 m (19 ft. 8 in.)	5.75 m (18 ft. 10 in.)	6.00 m (19 ft. 8 in.)
B	Maximum Dumping Height	4.07 m (13 ft. 4 in.)	4.31 m (14 ft. 2 in.)	4.07 m (13 ft. 4 in.)	4.31 m (14 ft. 2 in.)
C	Maximum Digging Depth	3.53 m (11 ft. 7 in.)	3.83 m (12 ft. 7 in.)	3.53 m (11 ft. 7 in.)	3.83 m (12 ft. 7 in.)
D	Maximum Digging Reach	5.96 m (19 ft. 7 in.)	6.26 m (20 ft. 6 in.)	5.96 m (19 ft. 7 in.)	6.26 m (20 ft. 6 in.)
E	Minimum Front Swing Radius	2.21 m (7 ft. 3 in.)	2.30 m (7 ft. 7 in.)	2.21 m (7 ft. 3 in.)	2.30 m (7 ft. 7 in.)
F	Transport Length	5.47 m (17 ft. 11 in.)	5.52 m (18 ft. 1 in.)	5.47 m (17 ft. 11 in.)	5.52 m (18 ft. 1 in.)
Digging Force (ISO)					
	Arm	24.0 kN (5,401 lb.)	21.0 kN (4,718 lb.)	24.0 kN (5,401 lb.)	21.0 kN (4,718 lb.)
	Bucket	36.8 kN (8,267 lb.)	36.8 kN (8,267 lb.)	36.8 kN (8,267 lb.)	36.8 kN (8,267 lb.)

Machine Dimensions		
G	Upperstructure Width	1.85 m (6 ft. 1 in.)
H	Overall Height	
	Canopy	2.53 m (8 ft. 4 in.)
	Cab	2.53 m (8 ft. 4 in.)
I	Track Width	400 mm (16 in.)
J	Undercarriage Width	2.00 m (6 ft. 7 in.)
K	Ground Clearance	340 mm (13 in.)
L	Tail Swing Radius	
	With Standard Arm	1.00 m (39 in.)
	With Long Arm and Extra Counterweight	1.10 m (43 in.)
M	Engine Cover Height	1.59 m (5 ft. 3 in.)
N	Maximum Blade Lift Above Ground	460 mm (18 in.)
O	Maximum Blade Drop Below Ground	360 mm (14 in.)
Blade		
	Width	2.00 m (6 ft. 7 in.)
	Height	375 mm (15 in.)
P	Sprocket Center to Idler Center	2.00 m (6 ft. 7 in.)
Q	Track Length	2.50 m (8 ft. 2 in.)
R	Counterweight Clearance	610 mm (24 in.)

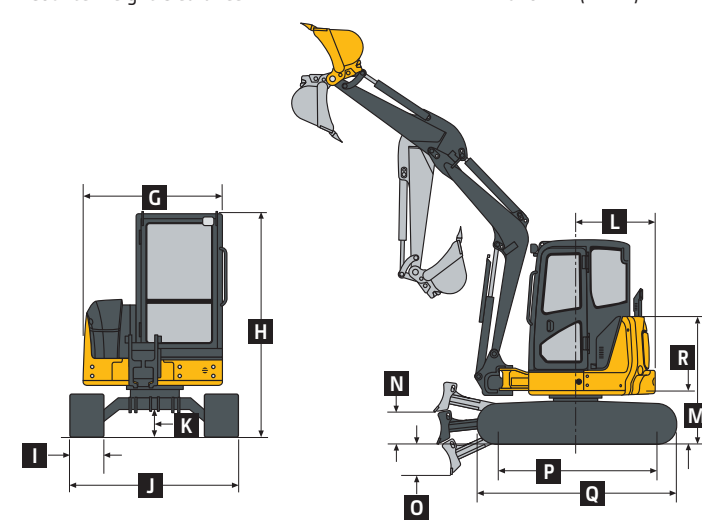
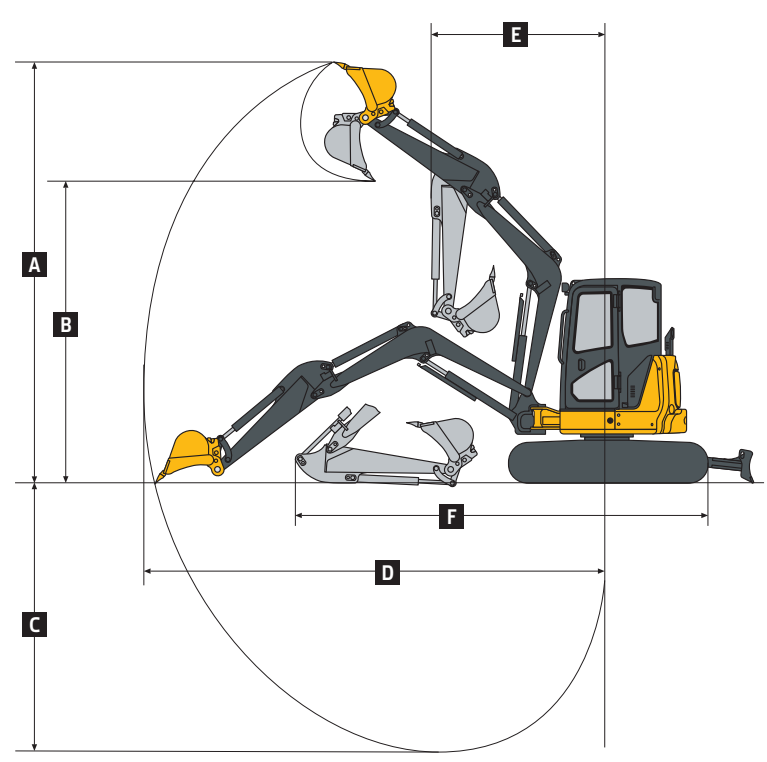

Lift Capacities		Canopy and Standard Counterweight		Canopy and Extra Counterweight		Cab and Standard Counterweight		Cab and Extra Counterweight	
Ground Level at 3.05-m (10 ft.) Radius		Over Front*	Over Side	Over Front*	Over Side	Over Front*	Over Side	Over Front*	Over Side
Arm									
	1380-mm (4 ft. 6 in.) Standard	2511 kg (5,531 lb.)	1110 kg (2,444 lb.)	2511 kg (5,531 lb.)	1232 kg (2,714 lb.)	2511 kg (5,531 lb.)	1150 kg (2,534 lb.)	2511 kg (5,531 lb.)	1273 kg (2,803 lb.)
	1690-mm (5 ft. 7 in.) Long	2477 kg (5,456 lb.)	1088 kg (2,396 lb.)	2477 kg (5,456 lb.)	1210 kg (2,666 lb.)	2477 kg (5,456 lb.)	1129 kg (2,486 lb.)	2477 kg (5,456 lb.)	1251 kg (2,755 lb.)

*Blade down (limited by hydraulics).

60G



Engine		60G			
Manufacturer and Model	Yanmar 4TNV98C				
Non-Road Emission Standard	EPA Final Tier 4/EU Stage IV				
Displacement	3.3 L (203 cu. in.)				
Net Power (ISO 9249)	39.6 kW (53 hp) at 2,000 rpm				
Powertrain					
Each track independently driven by hydrostatic axial-piston motor connected to 2-stage planetary gear-reduction box					
Maximum Travel Speed					
Low	2.9 km/h (1.8 mph)				
High	4.8 km/h (3.0 mph)				
Hydraulics					
Closed-center load sensing					
Main Pumps		1 variable-displacement pump			
Pump Flow	144 L/m (38.0 gpm)				
Auxiliary Flow	92 L/m (24.2 gpm)				
Controls	Hydraulic pilot-operated controls for boom, arm, bucket, swing, boom swing, blade, travel, and auxiliary functions				
Electrical					
Alternator Rating	55 amp				
Work Lights	2 halogen: 1 mounted on boom and 1 mounted on frame				
Undercarriage					
Track, Rubber	400 mm (16 in.)				
Ground Pressure		1500-mm (4 ft. 11 in.) Standard Arm and Standard Counterweight		1850-mm (6 ft. 1 in.) Long Arm and Extra Counterweight	
With Rubber Track	35 kPa (5.12 psi)		37 kPa (5.37 psi)		
Upperstructure					
Swing Speed	9.5 rpm				
Independent Swing Boom					
Left	80 deg.				
Right	60 deg.				
Swing Brake	Spring applied, hydraulically released, automatic, disc type				
Serviceability					
Refill Capacities					
Fuel Tank	120 L (31.7 gal.)				
Cooling System	7.7 L (8.1 qt.)				
Engine Oil with Filter	11.2 L (11.8 qt.)				
Hydraulic Tank	80 L (21.1 gal.)				
Operating Weights					
	1500-mm (4 ft. 11 in.) Standard Arm, Standard Counterweight, and Rubber Tracks	1500-mm (4 ft. 11 in.) Standard Arm, Standard Counterweight, and Steel Tracks	1850-mm (6 ft. 1 in.) Long Arm, Extra Counterweight, and Rubber Tracks	1850-mm (6 ft. 1 in.) Long Arm, Extra Counterweight, and Steel Tracks	
With 0.22-m ³ (7.8 cu. ft.) Bucket, Full Fuel Tank, and 79-kg (175 lb.) Operator	6145 kg (13,547 lb.)	6245 kg (13,768 lb.)	6443 kg (14,204 lb.)	6543 kg (14,425 lb.)	
Optional Angle Blade	458 kg (1,010 lb.)				
Counterweight					
Standard	745 kg (1,642 lb.)				
Additional	270 kg (595 lb.)				



Operating Dimensions		60G	
		1500-mm (4 ft. 11 in.) Standard Arm	1850-mm (6 ft. 1 in.) Long Arm
A	Maximum Cutting Height	5.96 m (19 ft. 7 in.)	6.19 m (20 ft. 4 in.)
B	Maximum Dumping Height	4.17 m (13 ft. 8 in.)	4.41 m (14 ft. 6 in.)
C	Maximum Digging Depth	3.77 m (12 ft. 4 in.)	4.12 m (13 ft. 6 in.)
D	Maximum Digging Reach	6.23 m (20 ft. 5 in.)	6.56 m (21 ft. 6 in.)
E	Minimum Front Swing Radius	2.45 m (8 ft. 0 in.)	2.54 m (8 ft. 4 in.)
F	Transport Length	5.76 m (18 ft. 11 in.)	5.90 m (19 ft. 4 in.)
Digging Force (ISO)			
	Arm	31.1 kN (6,989 lb.)	27.0 kN (6,063 lb.)
	Bucket	41.1 kN (9,237 lb.)	41.1 kN (9,237 lb.)

Machine Dimensions		60G	
G	Upperstructure Width	2.00 m (6 ft. 7 in.)	
H	Overall Height	2.54 m (8 ft. 4 in.)	
I	Track Width	400 mm (16 in.)	
J	Undercarriage Width	2.00 m (6 ft. 7 in.)	
K	Ground Clearance	340 mm (13 in.)	
L	Tail Swing Radius		
	With Standard Arm	1.30 m (4 ft. 3 in.)	
	With Long Arm and Extra Counterweight	1.41 m (4 ft. 8 in.)	
M	Engine Cover Height	1.60 m (5 ft. 3 in.)	
N	Maximum Blade Lift Above Ground	460 mm (18 in.)	
O	Maximum Blade Drop Below Ground	370 mm (15 in.)	
Blade			
	Width	2.00 m (6 ft. 7 in.)	
	Height	420 mm (16 in.)	
P	Sprocket Center to Idler Center	1.99 m (6 ft. 6 in.)	
Q	Track Length	2.50 m (8 ft. 2 in.)	
R	Counterweight Clearance	620 mm (24 in.)	

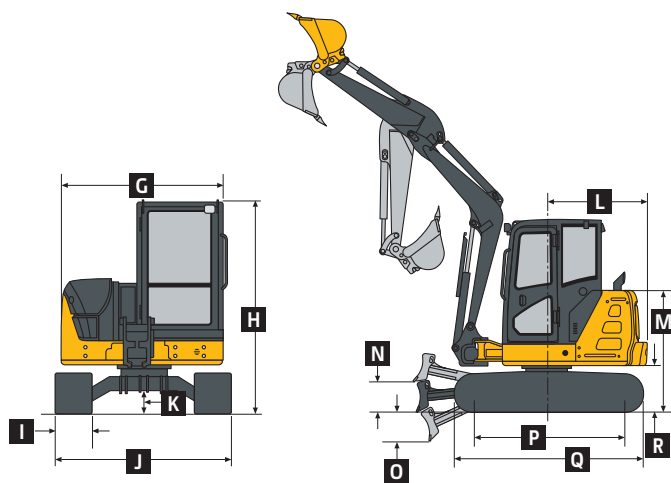
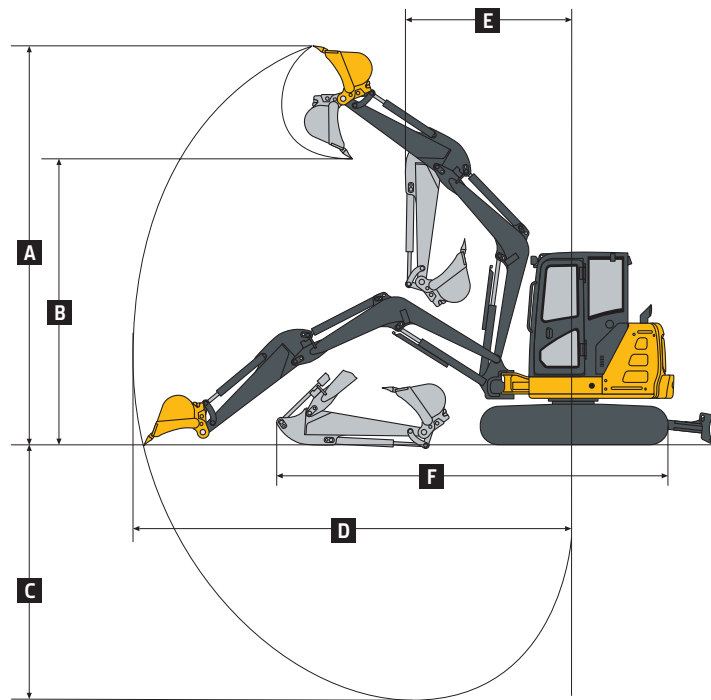

Lift Capacities		Standard Counterweight and Rubber Track		Standard Counterweight and Steel Track		Extra Counterweight and Rubber Track		Extra Counterweight and Steel Track	
Ground Level at 3.05-m (10 ft.) Radius		Over Front*	Over Side	Over Front*	Over Side	Over Front*	Over Side	Over Front*	Over Side
Arm	1500-mm (4 ft. 11 in.) Standard	3785 kg (8,345 lb.)	1463 kg (3,225 lb.)	3785 kg (8,345 lb.)	1490 kg (3,284 lb.)	3785 kg (8,345 lb.)	1657 kg (3,652 lb.)	3785 kg (8,345 lb.)	1683 kg (3,711 lb.)
	1850-mm (6 ft. 1 in.) Long	3719 kg (8,198 lb.)	1444 kg (3,184 lb.)	3719 kg (8,198 lb.)	1471 kg (3,243 lb.)	3719 kg (8,198 lb.)	1638 kg (3,612 lb.)	3719 kg (8,198 lb.)	1665 kg (3,671 lb.)

*Blade down (limited by hydraulics).

Additional equipment

Key: ● Standard ▲ Optional or special

See your John Deere dealer for further information.

35G	50G	60G	Engine
●	●	●	Meets EPA Final Tier 4/EU Stage IV emissions
●	●	●	Engine coolant to -37 deg. C (-34 deg. F)
●	●	●	Engine preheater
●	●	●	Fan guard
●	●	●	Fuel/water separator
●	●	●	Full-flow oil filter
●	●	●	Isolation mounted
●	●	●	Key start switch with electric fuel shutoff
●	●	●	Single dry-type air filter
			Hydraulic System
●	●	●	Auxiliary function right-hand pilot-lever control
●	●	●	Auxiliary hydraulic lines with quick-couplers to end of boom
●	●	●	Auxiliary return-flow selector valve
●	●	●	Axial-piston swing motor
●	●	●	Boom-swing foot control
●	●	●	Excavator-to-backhoe control pattern change valve
●			Open center with 2 variable-displacement pumps and 1 fixed-gear pump
	●	●	Closed center load sensing with 1 variable-displacement pump
●	●	●	Hydraulic pilot-operated controls for boom, arm, bucket, swing, boom swing, blade, travel, and auxiliary functions
●	●	●	Wet-disc swing brake
			Undercarriage
●	●	●	Planetary final drive
●	●	●	Propel motor shield
●	●	●	2-speed axial-piston propel motors
●			Rubber track, 300 mm (12 in.)
	●	●	Rubber track, 400 mm (16 in.)
▲			Steel track, 300 mm (12 in.) with triple semi-grousers
	▲	▲	Steel track, 400 mm (16 in.) with triple semi-grousers
▲			Rubber crawler pad, 300 mm (12 in.)
	▲	▲	Rubber crawler pad, 400 mm (16 in.)

35G	50G	60G	Upperstructure
●	●	●	360-deg. rotation
●			Counterweight, 540 kg (1,190 lb.)
	●		Counterweight, 700 kg (1,543 lb.)
		●	Counterweight, 745 kg (1,642 lb.)
●	●	●	Hinged service-access doors
	●	●	Toolbox
●	●		ROPS/TOPS/FOPS (canopy)
▲	▲	●	ROPS/TOPS/FOPS (cab) with air conditioning and heater
●	●	●	Vandal protection for service doors, fuel cap, and toolbox
●	●		Zero-tail-swing configuration
		●	Reduced-tail-swing configuration
			Front Attachments
●			Arm, 1315 mm (4 ft. 4 in.)
	●		Arm, 1380 mm (4 ft. 6 in.)
		●	Arm, 1500 mm (4 ft. 11 in.)
▲			Long arm, 1715 mm (5 ft. 8 in.), includes additional 240-kg (529 lb.) counterweight
	▲		Long arm, 1690 mm (5 ft. 7 in.), includes additional 200-kg (441 lb.) counterweight
		▲	Long arm, 1850 mm (6 ft. 1 in.), includes additional 270-kg (595 lb.) counterweight
●	●	●	Articulation hose shield
●			Backfill blade, 1.74 m (5 ft. 9 in.)
	●	●	Backfill blade, 2.00 m (6 ft. 7 in.)
▲	▲	▲	Hydraulic angle backfill blade
●			Boom, 2.465 m (8 ft. 1 in.)
	●		Boom, 2.85 m (9 ft. 4.2 in.)
		●	Boom, 2.965 m (9 ft. 9 in.)
●	●	●	Mechanical quick-coupler
▲	▲	▲	Augers: Planetary / Chain drive / Bits / Bit adapters
▲	▲	▲	Clamp
▲	▲	▲	Hammers: Points / Tools
▲	▲	▲	Quick-coupler buckets: Bucket teeth / Ditching / Heavy-duty

35G	50G	60G	Operator's Station
●	●	●	Horn
●	●	●	Hour meter
●	●	●	Instrumentation lights
●	●	●	Monitor system: Preheat indicator / Engine oil pressure indicator with alarm / Alternator voltage indicator / Fuel gauge and low-fuel-level indicator / Engine coolant temperature gauge and engine coolant temperature indicator with alarm / Hour meter / Work lights indicator
●	●	●	Motion alarm with cancel switch
●	●	●	Work lights switch
●	●	●	Propel levers and foldable pedals
●	●	●	2 travel speeds with automatic shifting
●	●	●	Seat belt, 51 mm (2 in.), retractable
▲	▲	▲	Seat belt, 76 mm (3 in.), retractable
●	●		Vinyl seat with fore/aft adjustment
▲	▲	●	Suspension seat (cloth)
▲	▲	▲	Front screen
▲	▲	▲	Rear secondary exit kit
			Electrical
●	●	●	12-volt accessory outlet
●	●	●	Alternator, 55 amp
●	●	●	Low-maintenance battery
●	●	●	Blade-type multi-fused circuits
●	●	●	Positive-terminal battery covers
▲	▲	▲	JDLINK™ wireless communication system (available in specific countries; see your dealer for details)
			Lights
●	●	●	Work lights: Halogen / 1 mounted on operator's station / 1 mounted on boom

Net engine power is with standard equipment including air cleaner, exhaust system, alternator, and cooling fan at test conditions per ISO 9249. These machines are not equipped with spark-arrestor mufflers. Usage in forestry applications is not recommended. Specifications and design subject to change without notice. Wherever applicable, specifications are in accordance with SAE standards. Except where otherwise noted, these specifications are based on units with standard arms, full fuel tanks, and 79-kg (175 lb.) operators; a 35G canopy unit with 610-mm (24 in.), 0.11-m³ (4.0 cu. ft.) bucket, 300-mm (12 in.) rubber track, and 540-kg (1,190 lb.) counterweight; a 50G canopy unit with 610-mm (24 in.), 0.16-m³ (5.7 cu. ft.) bucket, 400-mm (16 in.) rubber track, and 700-kg (1,543 lb.) counterweight; and a 60G cab unit with 0.19-m³ (6.8 cu. ft.) bucket, 400-mm (16 in.) rubber track, and 745-kg (1,642 lb.) counterweight.

