

35G



Engine		35G			
Manufacturer and Model	Yanmar 3TNV88F				
Non-Road Emission Standard	EPA Final Tier 4/EU Stage IV				
Displacement	1.642 L (100.2 cu. in.)				
Net Power (ISO 9249)	17.4 kW (23.3 hp) at 2,400 rpm				
Powertrain		Each track independently driven by hydrostatic axial-piston motor connected to 2-stage planetary gear-reduction box			
Maximum Travel Speed					
Low	2.8 km/h (1.7 mph)				
High	4.3 km/h (2.7 mph)				
Hydraulics		Open center with 2 variable-displacement pumps and 1 fixed-gear pump			
Pump Flow					
Piston	2 x 38.4 L/m (2 x 10.1 gpm)				
Gear	22.8 L/m (6.0 gpm)				
Auxiliary Flow	61.2 L/m (16.2 gpm)				
Controls	2 hydraulic pilot-operated controls for boom, arm, bucket, swing, boom swing, travel, and auxiliary functions				
Electrical					
Alternator Rating	55 amp				
Work Lights	2 halogen: 1 mounted on operator's station and 1 mounted on boom				
Undercarriage					
Track, Rubber	300 mm (12 in.)				
Ground Pressure		1315-mm (4 ft. 4 in.)			
	<i>Standard Arm, Canopy, and Standard Counterweight</i>	<i>1315-mm (4 ft. 4 in.) Standard Arm, Cab, and Standard Counterweight</i>	<i>1715-mm (5 ft. 8 in.) Long Arm, Canopy, and Extra Counterweight</i>	<i>1715-mm (5 ft. 8 in.) Long Arm, Cab, and Extra Counterweight</i>	
With Rubber Track	32.0 kPa (4.6 psi)	33.0 kPa (4.8 psi)	33.7 kPa (4.9 psi)	35.2 kPa (5.1 psi)	
Upperstructure					
Swing Speed	9.0 rpm				
Independent Swing Boom	<i>Canopy</i>	<i>Cab</i>			
Left	72 deg.	62 deg.			
Right	62 deg.	62 deg.			
Swing Brake	Spring applied, hydraulically released, automatic, disc type				
Serviceability					
Refill Capacities					
Fuel Tank	42 L (11.1 gal.)				
Cooling System	5.0 L (5.3 qt.)				
Engine Oil with Filter	7.2 L (7.6 qt.)				
Hydraulic Tank	32 L (8.5 gal.)				
Operating Weights		1315-mm (4 ft. 4 in.)			
	<i>Standard Arm, Canopy, and Standard Counterweight</i>	<i>1315-mm (4 ft. 4 in.) Standard Arm, Cab, and Standard Counterweight</i>	<i>1715-mm (5 ft. 8 in.) Long Arm, Canopy, and Extra Counterweight</i>	<i>1715-mm (5 ft. 8 in.) Long Arm, Cab, and Extra Counterweight</i>	
With Full Fuel Tank and 79-kg (175 lb.) Operator	3520 kg (7,760 lb.)	3690 kg (8,135 lb.)	3783 kg (8,340 lb.)	3953 kg (8,715 lb.)	
Optional Angle Blade	296 kg (653 lb.)				
Counterweight					
Standard	540 kg (1,190 lb.)				
Additional	240 kg (529 lb.)				



Operating Dimensions		35G			
		1315-mm (4 ft. 4 in.) Standard Arm and Canopy	1715-mm (5 ft. 8 in.) Long Arm and Canopy	1315-mm (4 ft. 4 in.) Standard Arm and Cab	1715-mm (5 ft. 8 in.) Long Arm and Cab
A	Maximum Cutting Height	4.87 m (16 ft. 0 in.)	4.95 m (16 ft. 3 in.)	4.70 m (15 ft. 5 in.)	4.74 m (15 ft. 7 in.)
B	Maximum Dumping Height	3.46 m (11 ft. 4 in.)	3.57 m (11 ft. 9 in.)	3.31 m (10 ft. 10 in.)	3.39 m (11 ft. 1 in.)
C	Maximum Digging Depth	3.06 m (10 ft. 0 in.)	3.46 m (11 ft. 4 in.)	3.06 m (10 ft. 0 in.)	3.46 m (11 ft. 4 in.)
D	Maximum Digging Reach	5.21 m (17 ft. 1 in.)	5.52 m (18 ft. 1 in.)	5.21 m (17 ft. 1 in.)	5.52 m (18 ft. 1 in.)
E	Minimum Front Swing Radius	2.08 m (6 ft. 10 in.)	2.19 m (7 ft. 2 in.)	2.24 m (7 ft. 4 in.)	2.30 m (7 ft. 7 in.)
F	Transport Length	4.64 m (15 ft. 3 in.)	4.75 m (15 ft. 7 in.)	4.64 m (15 ft. 3 in.)	4.75 m (15 ft. 7 in.)
Digging Force (ISO)					
	Arm	19.0 kN (4,277 lb.)	16.9 kN (3,792 lb.)	19.0 kN (4,277 lb.)	16.9 kN (3,792 lb.)
	Bucket	27.1 kN (6,085 lb.)	27.1 kN (6,085 lb.)	27.1 kN (6,085 lb.)	27.1 kN (6,085 lb.)

Machine Dimensions		
G	Upperstructure Width	1.55 m (5 ft. 1 in.)
H	Overall Height	
	Canopy	2.48 m (8 ft. 2 in.)
	Cab	2.48 m (8 ft. 2 in.)
I	Track Width	300 mm (12 in.)
J	Undercarriage Width	1.74 m (5 ft. 9 in.)
K	Ground Clearance	280 mm (11 in.)
L	Tail Swing Radius	
	With Standard Arm	870 mm (34 in.)
	With Long Arm and Extra Counterweight	980 mm (39 in.)
M	Engine Cover Height	1.53 m (5 ft. 0 in.)
N	Maximum Blade Lift Above Ground	360 mm (14.2 in.)
O	Maximum Blade Drop Below Ground	400 mm (15.7 in.)
Blade		
	Width	1.74 m (5 ft. 9 in.)
	Height	373 mm (14.7 in.)
P	Sprocket Center to Idler Center	1.66 m (5 ft. 5 in.)
Q	Undercarriage Length	2.11 m (6 ft. 11 in.)
R	Counterweight Clearance	550 mm (22 in.)

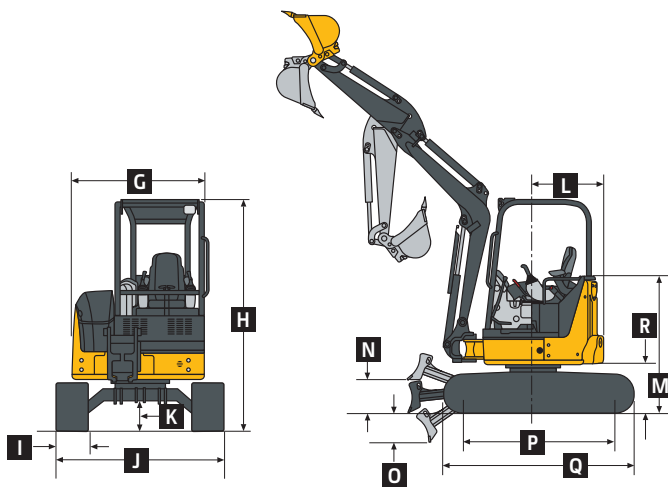
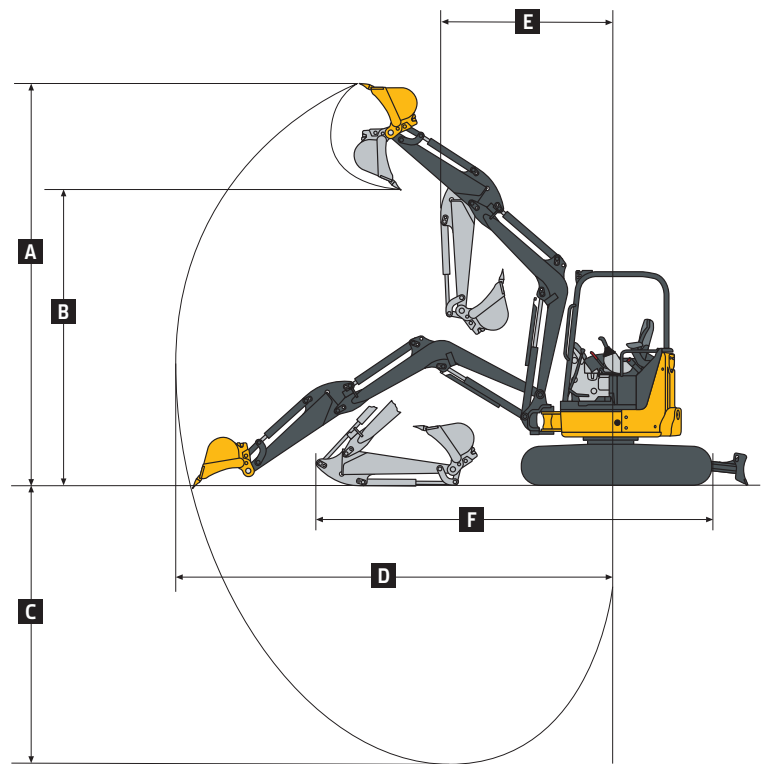

Lift Capacities									
Ground Level at 3.05-m (10 ft.) Radius		Canopy and Standard Counterweight		Canopy and Extra Counterweight		Cab and Standard Counterweight		Cab and Extra Counterweight	
Arm		Over Front*	Over Side	Over Front*	Over Side	Over Front*	Over Side	Over Front*	Over Side
	1315-mm (4 ft. 4 in.) Standard	1568 kg (3,453 lb.)	641 kg (1,412 lb.)	1568 kg (3,453 lb.)	765 kg (1,686 lb.)	1568 kg (3,453 lb.)	684 kg (1,506 lb.)	1568 kg (3,453 lb.)	808 kg (1,780 lb.)
	1715-mm (5 ft. 8 in.) Long	1501 kg (3,307 lb.)	630 kg (1,388 lb.)	1501 kg (3,307 lb.)	755 kg (1,662 lb.)	1501 kg (3,307 lb.)	672 kg (1,481 lb.)	1501 kg (3,307 lb.)	797 kg (1,756 lb.)

*Blade down (limited by hydraulics).