

345 P

Excavator



JOHN DEERE





SIZABLE SOLUTION FOR REAL-WORLD ACTION

Whether your work is in underground utilities, street repair, site development, or large-scale landscaping, the John Deere 345 P-Tier Excavator is purpose-built to deliver legendary performance. Masterful maneuverability, ease of operation, and proven components are just a few of the customer-inspired details that have earned our largest reduced-tail-swing machine a well-deserved reputation in the industry and on jobsites just like yours. Plus a versatile range of production-boosting standard advantages like a three-pump hydraulic system will help you realize all the tasks you can complete in your corner of the work world.

345 P-TIER EXCAVATOR

FEATURES



DPF no more

Efficient Isuzu engine burns particulate matter in the cylinder during combustion, eliminating ash-service intervals and regenerations, for EPA Final Tier 4/EU Stage IV aftertreatment without the need for a diesel particulate filter (DPF).

Close-quarter specialist

Maneuverable reduced-tail-swing model fits in tight or crowded spaces, minimizing the risk of damage to the machine or your surroundings. It also delivers exceptional reach, lift capacity, digging depth, breakout force, swing torque, and bucket capacity.

Full-size cab comfort

This reduced-tail-swing model features a spacious and well-appointed full-size cab. Standard rearview camera for enhanced awareness, cloth-covered high-back seat with generous legroom, a highly efficient HVAC system, and many other amenities help keep operators comfortable.

Take control

Ergonomically correct short-throw pilot levers enable smooth, predictable fingertip control with less movement or effort. Push buttons on the right joystick allow fingertip control of auxiliary hydraulic flow for operating attachments.



REDUCED-TAIL-SWING
EXCAVATOR WITH A
FULL-SIZE CAB

See it like never before

Integrated into the main monitor, optional right rear left camera system with additional LED surround lighting work together to supplement 270-degree visibility of the area around the machine, even in low-light conditions.

Dial it up

Multi-language LCD monitor and rotary dial provide intuitive access to a wealth of information and functions. Just turn and tap to select work mode, access operating info, check maintenance intervals, source diagnostic codes, adjust cab temperature, and tune the radio. Plus much more.

Go with the flow

Unique three-pump hydraulic system provides increased flow over two-pump designs. Third pump supplies additional hydraulic oil to the swing circuit as demanded, to maximize productivity without depleting oil reserves, slowing other functions, or sacrificing fuel economy.

Added leverage

When the going gets tough, simply press the standard power-boost button on the right-hand control and muscle through.

Play it cool

Highly efficient heavy-duty cooling system keeps things cool, even in tough environments or high altitudes. Side-by-side cooler cores maximize cooling efficiency and allow easy cleaning. Cool-on-demand suction-type fan helps reduce material buildup and maintenance.



345 P-TIER EXCAVATOR



3-PUMP HYDRAULIC SYSTEM MAXIMIZES PRODUCTIVITY

Job-proven undercarriage

The 345 P-tier shares the same tough undercarriage with our bigger 350 P-tier. With large idlers, rollers, and strutted links, this sealed and lubricated undercarriage delivers reliable performance and long wear life.

Explore your options

Choose from a variety of arm lengths, buckets, high-flow auxiliary hydraulic packages, and numerous other options to maximize machine flexibility and fleet utility.

Precision Construction

This suite of construction technology delivers **Productivity Solutions** to help you get more done, more efficiently. In-base JDLink™ connectivity provides machine location, utilization data, and alerts to help you maximize productivity and efficiency. To maximize uptime and lower costs, JDLink also enables **John Deere Connected Support™**. Dealers use Expert Alerts based on data from thousands of connected machines to proactively address conditions that may otherwise likely lead to downtime. Your dealer can also monitor machine health and leverage remote diagnostics and programming capability to further diagnose problems and even update machine software without a time-consuming trip to the jobsite.*

*Availability varies by region. Options not available in every country.





While general information, pictures, and descriptions are provided, some illustrations and text may include product options and accessories NOT AVAILABLE in all regions, and in some countries products and accessories may require modifications or additions to ensure compliance with the local regulations of those countries.

Engine		345 P-TIER	
Manufacturer and Model	Isuzu 6HK1XASA02		
Non-Road Emission Standard	EPA Final Tier 4/EU Stage IV		
Net Peak Power (ISO 9249)	186 kW (249 hp) at 1,900 rpm		
Cylinders	6		
Displacement	7.8 L (475 cu. in.)		
Off-Level Capacity	70% (35 deg.)		
Aspiration	Turbocharged, air-to-air charge-air cooler		
Cooling			
High-efficiency, direct-driven suction-type fan and enclosed fan guard; side-by-side radiator, oil cooler, and intercooler with dust net			
Powertrain			
2-speed propel with automatic shift			
Maximum Travel Speed			
Low	2.6 km/h (1.6 mph)		
High	4.1 km/h (2.5 mph)		
Drawbar Pull	30 388 kg (66,990 lb.)		
Hydraulics			
Open center, load sensing with variable-displacement pumps			
Main Pumps		3 variable-displacement axial-piston pumps	
Maximum Rated Flow			
Pump 1/Pump 2	235 L/m (62 gpm) x 2		
Pump 3	211 L/m (56 gpm) x 1		
Pilot Pump		1 gear	
Maximum Rated Flow	36 L/m (9.6 gpm)		
Pressure Setting	3900 kPa (566 psi)		
System Operating Pressure			
Circuits			
Implement	34 300 kPa (4,970 psi)		
Travel	35 500 kPa (5,150 psi)		
Swing	32 400 kPa (4,700 psi)		
Power Boost	38 000 kPa (5,510 psi)		
Controls		Pilot levers, short stroke, low-effort hydraulic pilot controls with shutoff lever	
Cylinders			
	<i>Bore</i>	<i>Rod Diameter</i>	<i>Stroke</i>
Boom (2)	135 mm (5.3 in.)	100 mm (3.9 in.)	1578 mm (62.1 in.)
Arm (1)	150 mm (5.9 in.)	105 mm (4.1 in.)	1659 mm (65.3 in.)
Bucket (1)	135 mm (5.3 in.)	90 mm (3.5 in.)	1070 mm (42.1 in.)
Electrical			
Voltage	24 volt		
Number of Batteries (12 volt)	2		
Battery Capacity	860 CCA		
Alternator Rating	50 amp		
Work Lights	5 LED (1 mounted on frame, 1 on boom left [standard], 2 on top of cab [optional], 1 on boom right)		
Undercarriage			
Rollers (each side)			
Carrier (upper)	2		
Track (lower)	8		
Shoes, Triple Semi-Grousers (each side)	48		
Track			
Adjuster	Hydraulic		
Guides	3 per side		
Chain	Sealed and lubricated		

345 P-TIER EXCAVATOR SPECIFICATIONS

345

P

While general information, pictures, and descriptions are provided, some illustrations and text may include product options and accessories NOT AVAILABLE in all regions, and in some countries products and accessories may require modifications or additions to ensure compliance with the local regulations of those countries.

Ground Pressure	345 P-TIER
800-mm (32 in.) Triple Semi-Grouser Shoes	50 kPa (7.3 psi)

Swing Mechanism	
Swing	
Speed	10.5 rpm
Torque	90 500 Nm (66,750 lb.-ft.)

Serviceability			
Refill Capacities	Refill Capacities (continued)		
Fuel Tank	380 L (100 gal.)	Hydraulic System	330 L (87 gal.)
Cooling System	48 L (12.7 gal.)	Hydraulic Tank	160 L (42 gal.)
Engine Oil With Filter	48 L (12.7 gal.)	Swing Bearing Grease Bath	19 kg (41.9 lb.)
Gearbox		Pump Drive Gear Case	1.7 L (1.8 qt.)
Swing	11.7 L (3.1 gal.)	Diesel Exhaust Fluid (DEF) Tank	16 L (4.2 gal.)
Travel (each)	11 L (2.9 gal.)		

Operating Weights	
With full fuel tank; 79-kg (175 lb.) operator; 1.25-m ³ (1.63 cu. yd.), 1067-mm (42 in.), 957-kg (2,110 lb.) bucket; 3.76-m (12 ft. 4 in.) arm; 8680-kg (19,136 lb.) counterweight; and 800-mm (32 in.) triple semi-grouser shoes	
SAE Operating Weight	35 700 kg (78,705 lb.)

Component Weights	
Undercarriage	
800-mm (32 in.) Triple Semi-Grouser Shoes	12 710 kg (28,021 lb.)
6.2-m (20 ft. 4 in.) Standard Boom	2385 kg (5,258 lb.)
Arm With Bucket Cylinder and Linkage	
3.11-m (10 ft. 2 in.) Long Without Cylinder	1494 kg (3,294 lb.)
3.76-m (12 ft. 4 in.) Long Without Cylinder	1583 kg (3,490 lb.)
Boom-Lift Cylinders (2), Total Weight	584 kg (1,287 lb.)
Cylinder (1), Total Weight	
Arm	348 kg (767 lb.)
Bucket	211 kg (465 lb.)

Operating Dimensions			
Arm Length With 6.2-m (20 ft. 4 in.) Standard Boom			
	<i>3.11 m (10 ft. 2 in.)</i>	<i>3.76 m (12 ft. 4 in.)</i>	
Arm Digging Force			
ISO	144 kN (32,370 lb.)	127 kN (28,550 lb.)	
SAE	138 kN (31,020 lb.)	121 kN (27,200 lb.)	
Bucket Digging Force			
ISO	202 kN (45,410 lb.)	202 kN (45,410 lb.)	
SAE	175 kN (39,340 lb.)	175 kN (39,340 lb.)	
Working Ranges			
A Maximum Reach	10.90 m (35 ft. 9 in.)	11.46 m (37 ft. 7 in.)	
A' Maximum Reach at Ground Level	10.64 m (34 ft. 11 in.)	11.22 m (36 ft. 10 in.)	
B Maximum Digging Depth	6.92 m (22 ft. 8 in.)	7.57 m (24 ft. 10 in.)	
B' Maximum Digging Depth at 2.44-m (8 ft. 0 in.) Flat Bottom	6.74 m (22 ft. 1 in.)	7.41 m (24 ft. 4 in.)	
C Maximum Cutting Height	11.41 m (37 ft. 5 in.)	11.69 m (38 ft. 4 in.)	
D Maximum Dumping Height	8.38 m (27 ft. 6 in.)	8.67 m (28 ft. 5 in.)	
E Minimum Swing Radius	3.40 m (11 ft. 2 in.)	3.39 m (11 ft. 1 in.)	
F Maximum Vertical Wall	6.14 m (20 ft. 2 in.)	6.71 m (22 ft. 0 in.)	

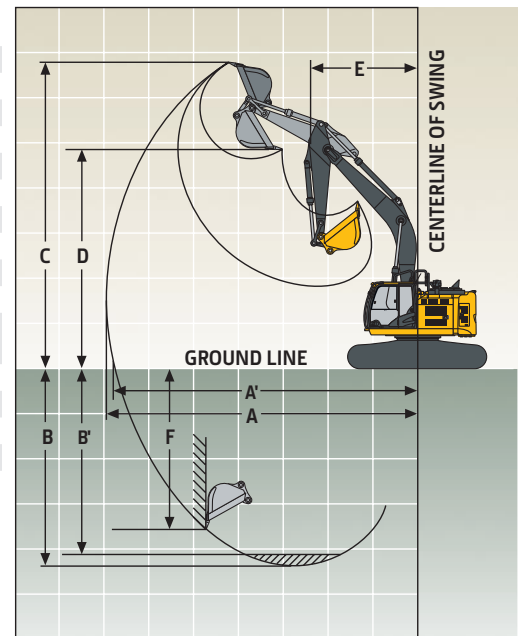

345 P-TIER

While general information, pictures, and descriptions are provided, some illustrations and text may include product options and accessories NOT AVAILABLE in all regions, and in some countries products and accessories may require modifications or additions to ensure compliance with the local regulations of those countries.

Machine Dimensions	345 P-TIER	
Arm Length	3.11 m (10 ft. 2 in.)	3.76 m (12 ft. 4 in.)
A Overall Length With Arm	9.96 m (32 ft. 8 in.)	10.02 m (32 ft. 10 in.)
B Overall Height of Boom With Arm	3.35 m (11 ft. 0 in.)	3.42 m (11 ft. 3 in.)
C Rear-End Length/Swing Radius	2.09 m (6 ft. 10 in.)	2.09 m (6 ft. 10 in.)
D Distance Between Idler/Sprocket Centerline	4.05 m (13 ft. 3 in.)	4.05 m (13 ft. 3 in.)
E Undercarriage Length	4.94 m (16 ft. 2 in.)	4.94 m (16 ft. 2 in.)
F Counterweight Clearance	1.16 m (3 ft. 10 in.)	1.16 m (3 ft. 10 in.)
G Upperstructure Width	3.05 m (10 ft. 0 in.)	3.05 m (10 ft. 0 in.)
H Cab Height	3.23 m (10 ft. 7 in.)	3.23 m (10 ft. 7 in.)
I Track Width With Triple Semi-Grouser Shoes	800 mm (32 in.)	800 mm (32 in.)
J Gauge Width	2.59 m (8 ft. 6 in.)	2.59 m (8 ft. 6 in.)
K Ground Clearance	500 mm (20 in.)	500 mm (20 in.)
L Overall Width With 800-mm (32 in.) Triple Semi-Grouser Shoes	3.39 m (11 ft. 1 in.)	3.39 m (11 ft. 1 in.)

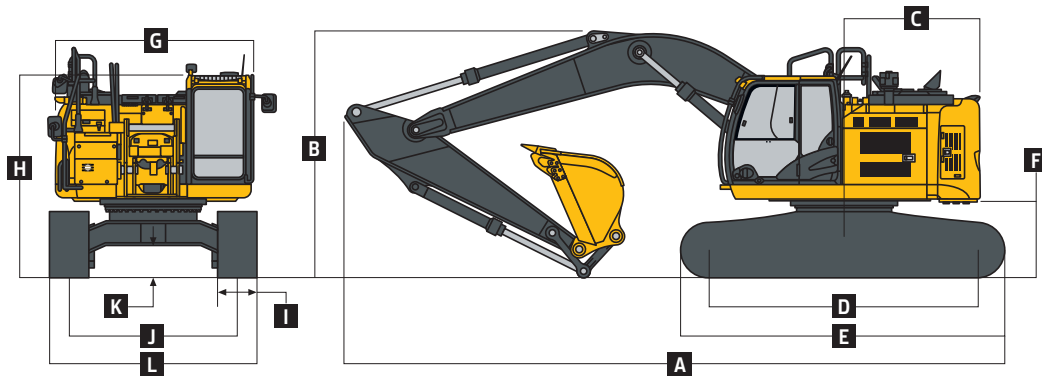

While general information, pictures, and descriptions are provided, some illustrations and text may include product options and accessories NOT AVAILABLE in all regions, and in some countries products and accessories may require modifications or additions to ensure compliance with the local regulations of those countries.

345 P-TIER

Lift Capacities 345 P-TIER

Boldface type indicates hydraulically limited capacity; lightface type indicates stability-limited capacity, in kg (lb.). Ratings at bucket lift hook; machine equipped with 6.2-m (20 ft. 4 in.) standard boom; 800-mm (32 in.) triple semi-grouser shoes; standard gauge; and situated on firm, uniform supporting surface. Total load includes weight of cables, hook, etc. Figures do not exceed 87 percent of hydraulic capacities or 75 percent of weight needed to tip machine. All lift capacities are based on ISO 10567 (with power boost).

LOAD POINT HEIGHT	HORIZONTAL DISTANCE FROM CENTERLINE OF ROTATION											
	1.5 m (5 ft.)		3.0 m (10 ft.)		4.5 m (15 ft.)		6.0 m (20 ft.)		7.5 m (25 ft.)		9.0 m (30 ft.)	
	Over Front	Over Side	Over Front	Over Side	Over Front	Over Side	Over Front	Over Side	Over Front	Over Side	Over Front	Over Side
<i>With 3.11-m (10 ft. 2 in.) arm, less bucket</i>												
7.5 m (25 ft.)							7850	7850				
							(17,090)	(17,090)				
6.0 m (20 ft.)							8770	8770	7910	6220		
							(19,090)	(19,060)	(16,800)	(13,400)		
4.5 m (15 ft.)					12 770	12 770	10 060	8460	8700	6040		
					(27,420)	(27,420)	(21,800)	(18,260)	(18,950)	(13,030)		
3.0 m (10 ft.)					16 020	12 060	11 570	8010	9440	5820	7040	4440
					(34,440)	(26,070)	(25,010)	(17,300)	(20,510)	(12,560)	(13,520)	(9,560)
1.5 m (5 ft.)					15 040	11 380	12 750	7630	9390	5610	7190	4340
					(36,160)	(24,550)	(27,590)	(16,470)	(20,230)	(12,110)	(14,790)	(9,350)
Ground Line					15 990	11 120	12 890	7400	9230	5470		
					(37,300)	(23,960)	(27,730)	(15,970)	(19,890)	(11,800)		
-1.5 m (-5 ft.)			10 750	10 750	17 260	11 100	12 800	7320	9170	5410		
			(24,300)	(24,300)	(37,450)	(23,890)	(27,530)	(15,800)	(19,770)	(11,700)		
-3.0 m (-10 ft.)			17 180	17 180	15 260	11 230	11 610	7380				
			(38,970)	(38,970)	(33,010)	(24,180)	(25,040)	(15,930)				
-4.5 m (-15 ft.)			15 060	15 060	11 630	11 530	8430	7630				
			(32,200)	(32,200)	(24,780)	(24,780)	(17,480)	(16,540)				
<i>With 3.76-m (12 ft. 4 in.) arm, less bucket</i>												
7.5 m (25 ft.)									5760	5760		
									(12,130)	(12,130)		
6.0 m (20 ft.)							7060	7060	6750	6320		
							(15,430)	(15,430)	(14,580)	(13,620)		
4.5 m (15 ft.)					10 880	10 880	9180	8620	8090	6120	6030	4590
					(22,770)	(22,770)	(19,890)	(18,610)	(17,530)	(13,200)	(12,360)	(9,870)
3.0 m (10 ft.)					14 590	12 420	10 800	8140	8940	5880	7290	4460
					(31,380)	(26,820)	(23,370)	(17,580)	(19,420)	(12,680)	(15,110)	(9,610)
1.5 m (5 ft.)					17 180	11 570	12 220	7700	9420	5630	7190	4330
					(37,090)	(24,950)	(26,460)	(16,630)	(20,310)	(12,160)	(15,490)	(9,340)
Ground Line			6400	6400	17 270	11 140	12 910	7410	9220	5450	7080	4230
			(14,520)	(14,520)	(39,300)	(23,990)	(27,770)	(15,980)	(19,870)	(11,770)	(15,270)	(9,140)
-1.5 m (-5 ft.)	7120	7120	10 110	10 110	17 790	11 000	12 740	7260	9110	5350		
	(15,880)	(15,880)	(22,820)	(22,820)	(38,570)	(23,690)	(27,420)	(15,670)	(19,640)	(11,560)		
-3.0 m (-10 ft.)	10 920	10 920	14 850	14 850	16 320	11 060	12 250	7260	9120	5360		
	(24,440)	(24,440)	(33,620)	(33,620)	(35,330)	(23,820)	(26,460)	(15,680)	(19,680)	(11,600)		
-4.5 m (-15 ft.)			18 400	18 400	13 480	11 290	10 110	7420				
			(39,520)	(39,520)	(28,930)	(24,330)	(21,520)	(16,030)				

345 P-TIER

While general information, pictures, and descriptions are provided, some illustrations and text may include product options and accessories NOT AVAILABLE in all regions, and in some countries products and accessories may require modifications or additions to ensure compliance with the local regulations of those countries.

Buckets 345 P-TIER

A full line of buckets is offered to meet a wide variety of applications. Digging forces are with power boost. Buckets are equipped with John Deere TK-Series Bucket Teeth standard. Replaceable cutting edges and a variety of teeth are available through John Deere Parts. Optional side cutters add 150 mm (6 in.) to bucket widths. Capacities are SAE heaped ratings.

Bucket Type	Bucket Width		Bucket Capacity		Bucket Weight	
	mm	in.	m ³	cu. yd.	kg	lb.
Heavy Duty	915	36	0.85	1.11	983	2,167
	1067	42	1.04	1.36	1088	2,398
	1220	48	1.22	1.60	1206	2,660
	1372	54	1.41	1.85	1284	2,832
	1524	60	1.60	2.09	1390	3,065

Bucket Selection Guide*

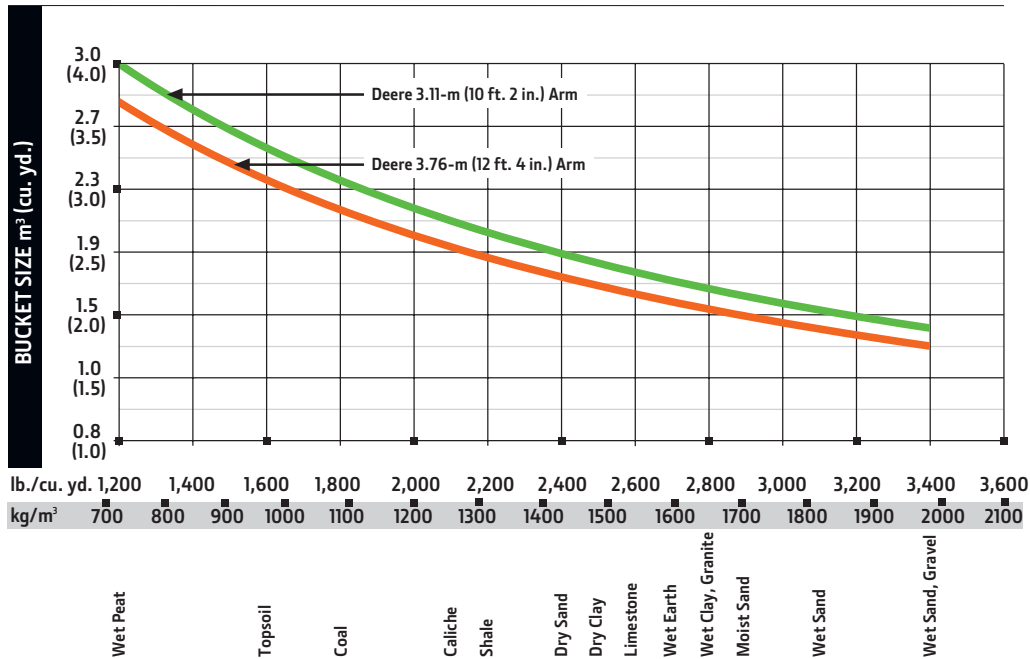

*Contact your John Deere dealer for optimum bucket and attachment selections. These recommendations are for general conditions and average use. Does not include optional equipment such as thumbs or couplers. Larger buckets may be possible when using light materials, for flat and level operations, less compacted materials, and volume loading applications such as mass-excavation applications in ideal conditions. Smaller buckets are recommended for adverse conditions such as off-level applications, rocks, and uneven surfaces. Bucket capacity indicated is SAE heaped.

Additional equipment

Key: ● Standard ▲ Optional or special
See your John Deere dealer for further information.

345 P Engine

- Auto-idle system
- Automatic belt-tension device
- Batteries (2 – 12 volt)
- Coolant recovery tank
- Dual-element dry-type air filter
- Electronic engine control
- Enclosed fan guard (conforms to SAE J1308)
- Engine coolant to –37 deg. C (–34 deg. F)
- Programmable auto shutdown
- Fuel filter with water separator
- Full-flow oil filter
- Turbocharger with charge-air cooler
- High-efficiency, direct-driven, suction-type fan and enclosed fan guard
- 500-hour engine-oil-change interval
- 70% (35 deg.) off-level capability
- ▲ Engine-oil-sampling valve
- ▲ Severe-duty fuel filter

Hydraulic System

- Reduced-drift valve for boom down, arm in
- Auxiliary hydraulic valve section
- Spring-applied, hydraulically released automatic swing brake
- Auxiliary hydraulic-flow adjustments through monitor
- Auto power lift
- 5,000-hour hydraulic-oil-change interval
- Auxiliary hydraulic lines with proportional control on right-hand pilot lever
- ▲ Hydraulic-oil-sampling valve
- ▲ Hydraulic filter restriction indicator kit
- ▲ Load-lowering control
- ▲ Single-pedal propel control
- ▲ Control pattern change valve

Undercarriage

- Planetary drive with axial piston motors
- Propel motor shields
- Spring-applied, hydraulically released automatic propel brake
- Track guides, front idler and 3 additional
- 2-speed propel with automatic shift
- Upper carrier rollers (2)
- Sealed and lubricated track chain
- ▲ Triple semi-grouser shoes, 800 mm (32 in.)

345 P Upperstructure

- Right-hand, left-hand, and counter-weight mirrors
- Vandal locks with ignition key: Cab door / Service doors / Toolbox
- Debris screening
- Service handrails
- Remote-mounted engine oil and fuel filters

Front Attachments

- Centralized lubrication system
- Dirt seals on all bucket pins
- Oil-impregnated bushings
- Reinforced resin thrust plates
- Tungsten carbide thermal coating on arm-to-bucket joint
- ▲ Arm, 3.11 m (10 ft. 2 in.)
- ▲ Arm, 3.76 m (12 ft. 4 in.)
- ▲ Attachment quick-couplers
- ▲ Buckets: Heavy duty / Heavy-duty high capacity / Side cutters and teeth
- ▲ Material clamps/Hydraulic thumb

Operator's Station

- Adjustable independent-control positions (levers-to-seat, seat-to-pedals)
- AM/FM radio
- Auto climate control/air conditioner/heater/pressurizer
- Built-in Operator's Manual storage compartment and manual
- Cell-phone power outlet, 12 volt, 60 watt, 5 amp
- Coat hook
- Deluxe suspension cloth seat with 100-mm (4 in.) adjustable armrests
- Floor mat
- Front windshield wiper with intermittent speeds
- Gauges (illuminated): Diesel Exhaust Fluid (DEF) / Engine coolant / Fuel
- Horn, electric
- Hour meter, electric
- Hydraulic shutoff lever, all controls
- Hydraulic warm-up control
- Interior light
- Large cup holder
- Machine Information Center (MIC)

345 P Operator's Station (continued)

- Mode selectors (illuminated): Power modes (3) / Travel modes (2 with automatic shift) / Work mode (1)
- Multifunction, color LCD monitor with: Diagnostic capability / Multiple-language capabilities / Maintenance tracking / Clock / System monitoring with alarm features: Auto-idle indicator, engine air cleaner restriction indicator light, engine check, engine coolant temperature indicator light with audible alarm, engine oil pressure indicator light with audible alarm, low-alternator-charge indicator light, low-fuel indicator light, low DEF indication with audible alarm, fault code alert indicator, fuel-rate display, wiper-mode indicator, work-lights-on indicator, and work-mode indicator
- Motion alarm with cancel switch (conforms to SAE J994)
- Power-boost switch on right console lever
- SAE 2-lever control pattern
- Seat belt, 76 mm (3 in.), retractable
- Tinted glass
- Transparent tinted overhead hatch
- Hot/cold beverage compartment
- Air-suspension heated seat
- ▲ Protection screens for cab front, rear, and side
- ▲ Window vandal-protection covers

Electrical

- 50-amp alternator
 - Blade-type multi-fused circuits
 - Positive-terminal battery covers
 - Battery-disconnect switch
 - JDLINK™ wireless communication system (available in specific countries; see your dealer for details)
 - Rearview camera
 - ▲ Right rear left 270-deg. camera system with additional LED surround lighting
- ## Lights
- Work lights: 5 LED (1 mounted on frame, 1 on boom left [standard], 2 on top of cab [optional], and 1 on boom right)
 - ▲ 2 lights on front of cab / 1 rear cab light

While general information, pictures, and descriptions are provided, some illustrations and text may include product options and accessories NOT AVAILABLE in all regions, and in some countries products and accessories may require modifications or additions to ensure compliance with the local regulations of those countries.

Net engine power is with standard equipment including air cleaner, exhaust system, alternator, and cooling fan, at test conditions specified per ISO 9249. No derating is required up to 3050-m (10,000 ft.) altitude. Specifications and design subject to change without notice. Wherever applicable, specifications are in accordance with SAE standards. Except where otherwise noted, these specifications are based on a unit with 1.25-m³ (1.63 cu. yd.), 1067-mm (42 in.), 957-kg (2,110 lb.) bucket; 3.76-m (12 ft. 4 in.) arm; 8680-kg (19,136 lb.) counterweight, 800-mm (32 in.) triple semi-grouser shoes, full fuel tank, and 79-kg (175 lb.) operator.



ME345PAJ (22-11)



JOHN DEERE