

G-SERIES  
**345G LC EXCAVATOR**



**JOHN DEERE**



**AGILITY MEETS  
CAPABILITY**

THE  
**345G LC**



***STREETW***

# USE.



REDUCED  
TAIL SWING

+



PERFORMANCE



## ***URBAN RENEWAL.***

Whether your work is street repair, underground utilities, site development, or landscaping, the 345G LC Excavator will revitalize your operation as you rejuvenate your community. Meeting customer demand for a larger reduced-tail-swing excavator, the 345G LC improves your capability to work in congested areas or around traffic.



# COMES OUT FIGHTING

*SAVES YOUR TAIL (AND ITS OWN).*

The 345G LC Excavator performs best with its back against the wall. Its reduced-tail-swing design helps you maximize productivity when you're between a rock and a hard place.

## Go with the flow

Three-pump hydraulic system delivers superb hydraulic flow. With one pump dedicated to the swing circuit, hydraulic flow is never compromised — for fast cycle times and smooth multifunction performance.

## Explore your options

Choose from a variety of arm lengths, buckets, high-flow auxiliary hydraulic packages, and numerous other options. The 345G LC coupler is compatible with the attachments available for the 300G LC, to help maximize fleet utility.

## Put your mind at ease

Redesigned pistons and fuel injectors enable the aftertreatment of the powerful 249-hp engine to meet EPA Final Tier 4/EU Stage IV emissions without a diesel particulate filter (DPF). High-efficiency combustion means that no fuel is left over, no damaging soot is created, and no components need to be replaced — to minimize maintenance requirements and worries.



**THREE-PUMP  
HYDRAULIC  
SYSTEM**



STANDOUT FEATURE



MORE POWER IN  
**CLOSE QUARTERS**



# **TIGHT JOBSITES AND DEADLINES?**

**HELP HAS ARRIVED.**

The 345G LC offers a larger alternative to the popular 245G LC — to help you complete big projects more efficiently.

### **More performance**

This close-quarters specialist delivers more reach, lift capacity, digging depth, breakout force, swing torque, and bucket capacity than previous models.

### **The tough get going**

When the going gets tough, simply press the power-boost button on the right-hand control and muscle through.



**MORE  
BREAKOUT  
FORCE**  
THAN PREVIOUS MODELS

# **RS.**

# WON'T CRAMP YOUR STYLE

*LESS CONFINED, MORE REFINED.*

A smaller back end doesn't mean a cramped workspace. The 345G LC is a reduced-tail-swing machine boasting a full-size cab. Step inside and make yourself at home.

## Ready to work

Operators will appreciate the fabric-covered high-back seat and generous legroom in the spacious, well-appointed cab. As always, excellent visibility, low-effort joysticks, a highly efficient HVAC system, and numerous other amenities provide what you need to do your best work.

## Low-effort controls

Ergonomically correct short-throw pilot levers provide predictable, smooth control with minimal movement or effort. Push buttons on the right joystick allow fingertip control of auxiliary hydraulic flow for operating attachments.

## See more, do more

Hood design enables optimal visibility to the sides and rear. Standard rearview camera expands the view even more, showing the action behind the machine on the front monitor.

## Light it up

Optional cab and right-side boom lights provide extra illumination to extend your workday beyond daylight hours.

## Put more productivity on speed dial

The refined monitor employs a rotary control that makes it quick and easy to tap into an abundance of performance and convenience functions and features.







REDUCED-TAIL-SWING  
MACHINE WITH A  
**FULL-SIZE CAB**



---

# ***SERVICE MADE SIMPLE***

*REDUCES COSTS, TOO.*

## **Job-proven undercarriage**

The 345G LC shares the same tough undercarriage with the bigger 350G LC. With large idlers, rollers, and strutted links, this sealed and lubricated undercarriage delivers long and reliable performance.

## **Keep free of debris**

Fine-mesh screen prevents large debris from entering the engine compartment and coolers. The screen is easy to remove for quick cleaning.

## **Ground-level service checks**

Swing open the side panels for quick, convenient, ground-level access to filters and daily service points.

## **Extend battery life**

Easily accessible in the rear door behind the cab, the battery-disconnect switch helps extend battery life.

## **Play it cool**

Highly efficient heavy-duty cooling system keeps things cool, even in tough environments or high altitudes. Side-by-side cooler cores provide maximum cooling efficiency and allow easy cleaning.



---

Get valuable insight with

## **JOHN DEERE WORKSIGHT™**

The John Deere WorkSight suite of construction technology delivers **Productivity Solutions** to help you get more done, more efficiently. The in-base, five-year JDLink™ telematics subscription provides machine location, utilization data, and alerts to help you maximize productivity and efficiency. Other productivity solutions include grade-management and payload-weighting options.

To maximize uptime and lower costs, JDLink telematics also enables **John Deere Connected Support™**. John Deere's centralized Machine Health Monitoring Center analyzes data from thousands of connected machines, identifies trends, and develops actions to prevent downtime called Expert Alerts. Dealers use Expert Alerts to proactively address conditions that would otherwise likely lead to downtime. Your dealer can also monitor machine health and leverage remote diagnostics and programming capability to further diagnose problems and even update machine software without a time-consuming trip to the jobsite.





# 345G LC SPECIFICATIONS

<b>Engine</b>	<b>345G LC</b>		
Manufacturer and Model	Isuzu 6HK1XASA02		
Non-Road Emission Standard	EPA Final Tier 4/EU Stage IV		
Net Peak Power (ISO 9249)	186 kW (249 hp) at 1,900 rpm		
Cylinders	6		
Displacement	779 L (475 cu. in.)		
Off-Level Capacity	70% (35 deg.)		
Aspiration	Turbocharged, air-to-air charge-air cooler		
<b>Cooling</b>	Cool-on-demand, hydraulic-driven, suction-type fan with remote-mounted drive and enclosed fan guard; side-by-side radiator, oil cooler, and intercooler with dust net		
<b>Powertrain</b>	2-speed propel with automatic shift		
<b>Maximum Travel Speed</b>			
Low	2.6 km/h (1.6 mph)		
High	4.1 km/h (2.5 mph)		
Drawbar Pull	30 388 kg (66,990 lb.)		
<b>Hydraulics</b>	Open center, load sensing with variable-displacement pumps		
<b>Main Pumps</b>	3 variable-displacement axial-piston pumps		
Maximum Rated Flow			
Pump 1/Pump 2	235 L/m (62.1 gpm) x 2		
Pump 3	211 L/m (55.7 gpm) x 1		
<b>Pilot Pump</b>	1 gear		
Maximum Rated Flow	36.4 L/m (9.6 gpm)		
Pressure Setting	3900 kPa (566 psi)		
<b>System Operating Pressure</b>			
Circuits			
Implement	34 300 kPa (4,975 psi)		
Travel	35 500 kPa (5,149 psi)		
Swing	32 400 kPa (4,699 psi)		
Power Boost	38 000 kPa (5,511 psi)		
<b>Controls</b>	Pilot levers, short stroke, low-effort hydraulic pilot controls with shutoff lever		
<b>Cylinders</b>			
	<i>Bore</i>	<i>Rod Diameter</i>	<i>Stroke</i>
<b>Boom (2)</b>	135 mm (5.3 in.)	100 mm (3.9 in.)	1578 mm (62.1 in.)
<b>Arm (1)</b>	150 mm (5.9 in.)	105 mm (4.1 in.)	1659 mm (65.3 in.)
<b>Bucket (1)</b>	135 mm (5.3 in.)	90 mm (3.5 in.)	1070 mm (42.1 in.)
<b>Electrical</b>			
Voltage	24 volt		
Number of Batteries (12 volt)	2		
Battery Capacity	860 CCA		
Alternator Rating	50 amp		
Work Lights	3 halogen (1 mounted on frame, 2 mounted on boom)		
<b>Undercarriage</b>			
<b>Rollers (each side)</b>			
Carrier (upper)	2		
Track (lower)	8		
Shoes, Triple Semi-Grousers (each side)	48		
<b>Track</b>			
Adjuster	Hydraulic		
Guides	3 per side		
Chain	Sealed and lubricated		
<b>Ground Pressure</b>			
800-mm (32 in.) Triple Semi-Grouser Shoes	50 kPa (7.3 psi)		

# 345G LC SPECIFICATIONS



## Swing Mechanism 345G LC

<b>Swing</b>	
Speed	10.5 rpm
Torque	90 500 Nm (66,750 lb.-ft.)

## Serviceability

### Refill Capacities

Fuel Tank	380 L (100 gal.)
Diesel Exhaust Fluid (DEF) Tank	16 L (4.2 gal.)
Cooling System	41 L (10.8 gal.)
Engine Oil with Filter	48 L (12.7 gal.)
Hydraulic Tank	160 L (42 gal.)
Hydraulic System	330 L (87 gal.)
Swing Drive	12 L (3.2 gal.)
Gearbox	
Propel (each)	11 L (2.9 gal.)
Pump Drive Gear Case	1.1 L (1.2 qt.)
Swing Bearing Grease Bath	19 kg (41.9 lb.)

## Operating Weights

With full fuel tank; 79-kg (175 lb.) operator; 1.25-m<sup>3</sup> (1.63 cu. yd.), 1067-mm (42 in.), 957-kg (2,110 lb.) bucket; 3.76-m (12 ft. 4 in.) arm; 8680-kg (19,136 lb.) counterweight; and 800-mm (32 in.) triple semi-grouser shoes

SAE Operating Weight	35 700 kg (78,710 lb.)
----------------------	------------------------

## Component Weights

### Undercarriage

800-mm (32 in.) Triple Semi-Grouser Shoes	12 710 kg (28,021 lb.)
One-Piece Boom (with arm cylinder)	2385 kg (5,258 lb.)

### Arm with Bucket Cylinder and Linkage

3.76 m (12 ft. 4 in.)	1583 kg (3,490 lb.)
3.11 m (10 ft. 2 in.)	1494 kg (3,294 lb.)
Boom-Lift Cylinders (2), Total Weight	584 kg (1,287 lb.)
Cylinder (1), Total Weight	
Arm	348 kg (767 lb.)
Bucket	211 kg (465 lb.)

## Operating Dimensions

### Arm Length with 6.2-m (20 ft. 4 in.) Standard Boom

Arm Digging Force		
ISO	144 kN (32,370 lb.)	127 kN (28,550 lb.)
SAE	138 kN (31,020 lb.)	121 kN (27,200 lb.)
Bucket Digging Force		
ISO	202 kN (45,410 lb.)	202 kN (45,410 lb.)
SAE	175 kN (39,340 lb.)	175 kN (39,340 lb.)

### Working Ranges

<b>A</b> Maximum Reach	10.90 m (35 ft. 9 in.)	11.46 m (37 ft. 7 in.)
<b>A'</b> Maximum Reach at Ground Level	10.64 m (34 ft. 11 in.)	11.22 m (36 ft. 10 in.)
<b>B</b> Maximum Digging Depth	6.92 m (22 ft. 8 in.)	7.57 m (24 ft. 10 in.)
<b>B'</b> Maximum Digging Depth at 2.44-m (8 ft. 0 in.) Flat Bottom	6.74 m (22 ft. 1 in.)	7.41 m (24 ft. 4 in.)
<b>C</b> Maximum Cutting Height	11.41 m (37 ft. 5 in.)	11.69 m (38 ft. 4 in.)
<b>D</b> Maximum Dumping Height	8.38 m (27 ft. 6 in.)	8.67 m (28 ft. 5 in.)
<b>E</b> Minimum Swing Radius	3.40 m (11 ft. 2 in.)	3.39 m (11 ft. 1 in.)
<b>F</b> Maximum Vertical Wall	6.14 m (20 ft. 2 in.)	6.71 m (22 ft. 0 in.)

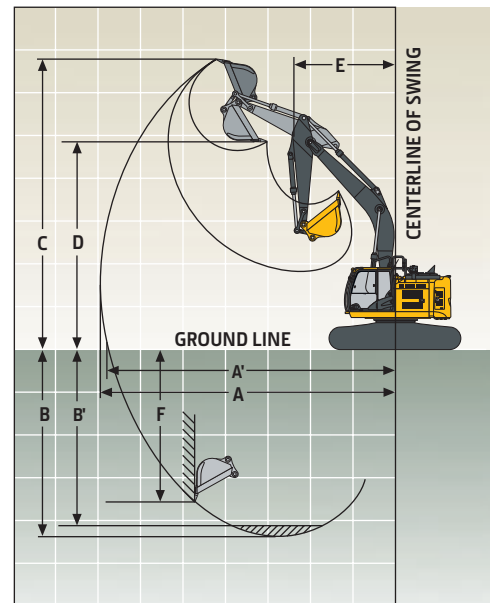

# 345G LC

Machine Dimensions		345G LC	
<b>Arm Length</b>		3.11 m (10 ft. 2 in.)	3.76 m (12 ft. 4 in.)
<b>A</b> Overall Length with Arm		9.96 m (32 ft. 8 in.)	10.02 m (32 ft. 10 in.)
<b>B</b> Overall Height with Arm		3.35 m (11 ft. 0 in.)	3.42 m (11 ft. 3 in.)
<b>C</b> Rear-End Length/Swing Radius		2.09 m (6 ft. 10 in.)	2.09 m (6 ft. 10 in.)
<b>D</b> Distance Between Idler/Sprocket Centerline		4.05 m (13 ft. 3 in.)	4.05 m (13 ft. 3 in.)
<b>E</b> Undercarriage Length		4.94 m (16 ft. 2 in.)	4.94 m (16 ft. 2 in.)
<b>F</b> Counterweight Clearance		1.16 m (3 ft. 10 in.)	1.16 m (3 ft. 10 in.)
<b>G</b> Upperstructure Width		3.05 m (10 ft. 0 in.)	3.05 m (10 ft. 0 in.)
<b>H</b> Cab Height		3.23 m (10 ft. 7 in.)	3.23 m (10 ft. 7 in.)
<b>I</b> Track Width with Triple Semi-Grouser Shoes		800 mm (32 in.)	800 mm (32 in.)
<b>J</b> Gauge Width		2.59 m (8 ft. 6 in.)	2.59 m (8 ft. 6 in.)
<b>K</b> Ground Clearance		500 mm (20 in.)	500 mm (20 in.)
<b>L</b> Overall Width with 800-mm (32 in.) Triple Semi-Grouser Shoes		3.39 m (11 ft. 1 in.)	3.39 m (11 ft. 1 in.)

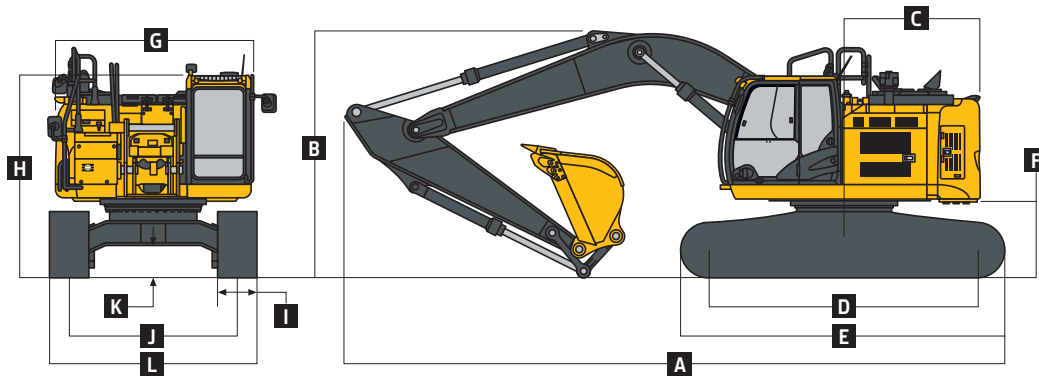

## Lift Capacities

**Boldface type** indicates hydraulically limited capacity; lightface type indicates stability-limited capacity, in kg (lb.). Ratings at bucket lift hook; machine equipped with 6.2-m (20 ft. 4 in.) standard boom; 1.25-m<sup>3</sup> (1.63 cu. yd.), 957-kg (2,110 lb.) bucket; 800-mm (32 in.) triple semi-grouser shoes; standard gauge; and situated on firm, uniform supporting surface. Total load includes weight of cables, hook, etc. Figures do not exceed 87 percent of hydraulic capacities or 75 percent of weight needed to tip machine. All lift capacities are based on ISO 10567 (with power boost).

LOAD POINT HEIGHT	HORIZONTAL DISTANCE FROM CENTERLINE OF ROTATION											
	1.5 m (5 ft.)		3.0 m (10 ft.)		4.5 m (15 ft.)		6.0 m (20 ft.)		7.5 m (25 ft.)		9.0 m (30 ft.)	
	Over Front	Over Side	Over Front	Over Side	Over Front	Over Side	Over Front	Over Side	Over Front	Over Side	Over Front	Over Side
<i>With 3.11-m (10 ft. 2 in.) arm</i>												
7.5 m (25 ft.)							<b>7050</b>	<b>7050</b>	<b>4850</b>	<b>4850</b>		
							(15,300)	(15,300)				
6.0 m (20 ft.)							<b>7950</b>	<b>7950</b>	<b>7100</b>	5550		
							(17,300)	(17,300)	(15,000)	(11,900)		
4.5 m (15 ft.)					<b>12 000</b>	<b>12 000</b>	<b>9250</b>	7750	<b>7900</b>	5350	<b>4350</b>	3850
					(25,650)	(25,650)	(20,050)	(16,750)	(17,200)	(11,500)		
3.0 m (10 ft.)					<b>15,250</b>	11 400	<b>10 800</b>	7350	<b>8650</b>	5150	<b>6250</b>	3750
					(32,700)	(24,600)	(23,250)	(15,800)	(18,750)	(11,050)	(11,750)	(8,050)
1.5 m (5 ft.)					<b>14 200</b>	10 700	<b>11 950</b>	6950	8750	4950	6550	3650
					(34,350)	(23,100)	(25,850)	(15,000)	(18,850)	(10,600)	(13,000)	(7,850)
Ground Line					<b>15 200</b>	10 450	12 300	6750	8600	4800	<b>5550</b>	3600
					(35,500)	(22,500)	(26,400)	(14,500)	(18,500)	(10,300)		
-1.5 m (-5 ft.)			<b>9950</b>	<b>9950</b>	<b>16 500</b>	10 450	<b>12 150</b>	6650	8550	4750		
			(22,500)	(22,500)	(35,750)	(22,450)	(26,200)	(14,300)	(18,350)	(10,200)		
-3.0 m (-10 ft.)			<b>16 350</b>	<b>16 350</b>	<b>14 500</b>	10 550	<b>10 850</b>	6700	<b>7850</b>	4800		
			(37,200)	(37,200)	(31,300)	(22,750)	(23,300)	(14,450)				
-4.5 m (-15 ft.)			<b>14 300</b>	<b>14 300</b>	<b>10 850</b>	<b>10 850</b>	<b>7650</b>	6950				
			(30,550)	(30,550)	(23,100)	(23,100)	(15,750)	(15,050)				

## Lift Capacities (continued) 345G LC

**Boldface type** indicates hydraulically limited capacity; lightface type indicates stability-limited capacity, in kg (lb.). Ratings at bucket lift hook; machine equipped with 6.2-m (20 ft. 4 in.) standard boom; 1.25-m<sup>3</sup> (1.63 cu. yd.), 957-kg (2,110 lb.) bucket; 800-mm (32 in.) triple semi-grouser shoes; standard gauge; and situated on firm, uniform supporting surface. Total load includes weight of cables, hook, etc. Figures do not exceed 87 percent of hydraulic capacities or 75 percent of weight needed to tip machine. All lift capacities are based on ISO 10567 (with power boost).

LOAD POINT HEIGHT	HORIZONTAL DISTANCE FROM CENTERLINE OF ROTATION													
	1.5 m (5 ft.)		3.0 m (10 ft.)		4.5 m (15 ft.)		6.0 m (20 ft.)		7.5 m (25 ft.)		9.0 m (30 ft.)			
	Over Front	Over Side	Over Front	Over Side	Over Front	Over Side	Over Front	Over Side	Over Front	Over Side	Over Front	Over Side		
With 3.76-m (12 ft. 4 in.) arm														
7.5 m (25 ft.)									4950	4950				
									(10,350)	(10,350)				
6.0 m (20 ft.)									6250	6250	5950	5650	3600	3600
									(13,650)	(13,650)	(12,800)	(12,100)		
4.5 m (15 ft.)					10 050	10 050	8400	7950	7300	5450	5200	5200	3900	
					(21,000)	(21,000)	(18,150)	(17,100)	(15,750)	(11,700)	(10,600)	(10,600)	(8,350)	
3.0 m (10 ft.)					13 800	11 750	10 000	7450	8150	5200	6500	6500	3800	
					(29,650)	(25,350)	(21,650)	(16,100)	(17,650)	(11,150)	(13,350)	(13,350)	(8,100)	
1.5 m (5 ft.)					16 400	10 900	11 450	7050	8800	4950	6550	6550	3650	
					(35,400)	(23,500)	(24,750)	(15,150)	(18,900)	(10,650)	(14,050)	(14,050)	(7,850)	
Ground Line			5600	5600	16 450	10 500	12 250	6750	8600	4800	6450	6450	3550	
			(12,750)	(12,750)	(37,600)	(22,550)	(26,400)	(14,500)	(18,450)	(10,250)	(13,850)	(13,850)	(7,650)	
-1.5 m (-5 ft.)	6300	6300	9300	9300	17 050	10 350	12 150	6600	8500	4700	5750	5750	3500	
	(14,100)	(14,100)	(21,050)	(21,050)	(36,900)	(22,250)	(26,050)	(14,200)	(18,250)	(10,050)				
-3.0 m (-10 ft.)	10 100	10 100	14 050	14 050	15 550	10 400	11 450	6600	8500	4700				
	(22,650)	(22,650)	(31,850)	(31,850)	(33,650)	(22,400)	(24,750)	(14,200)	(18,300)	(10,100)				
-4.5 m (-15 ft.)			17 650	17 650	12 700	10 650	9350	6750						
			(37,850)	(37,850)	(27,250)	(22,900)	(19,800)	(14,550)						

## Buckets

A full line of buckets is offered to meet a wide variety of applications. Digging forces are with power boost. Buckets are standard equipped with John Deere TK-Series bucket teeth. Replaceable cutting edges and a variety of teeth are available through John Deere Parts. Optional side cutters add 150 mm (6 in.) to bucket widths. Capacities are SAE heaped ratings.

Type Bucket	Bucket Width		Bucket Capacity		Bucket Weight		Bucket Dig Force		Arm Dig Force 3.11 m (10 ft. 2 in.)		Arm Dig Force 3.76 m (12 ft. 4 in.)		ISO Bucket Tip Radius		Number of Teeth
	mm	in.	m <sup>3</sup>	cu. yd.	kg	lb.	kN	lb.	kN	lb.	kN	lb.	mm	in.	
Heavy Duty	914	36	0.9	1.23	1010	2,226	189.7	42,653	144.1	32,397	125.1	28,126	1661	65.4	4
	1067	42	1.2	1.52	1147	2,530	189.7	42,653	144.1	32,397	125.1	28,126	1661	65.4	5
	1219	48	1.4	1.81	1213	2,675	189.7	42,653	144.1	32,397	125.1	28,126	1661	65.4	5
	1372	54	1.6	2.09	1328	2,928	189.7	42,653	144.1	32,397	125.1	28,126	1661	65.4	6

## Bucket Selection Guide\*

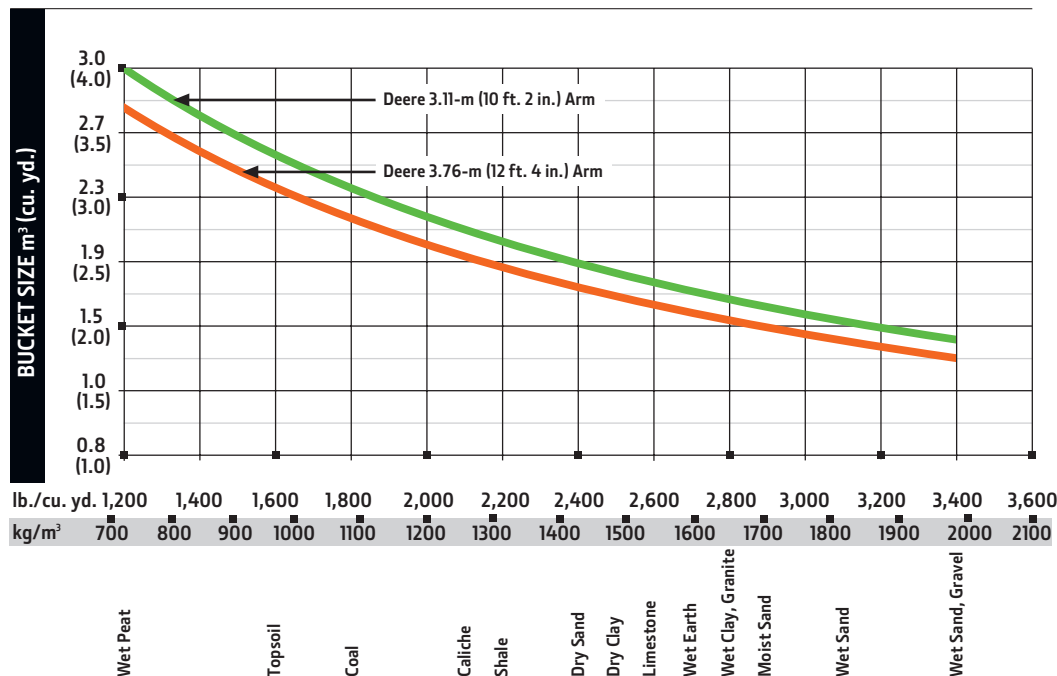

\*Contact your John Deere dealer for optimum bucket and attachment selections. These recommendations are for general conditions and average use. Does not include optional equipment such as thumbs or couplers. Larger buckets may be possible when using light materials, for flat and level operations, less compacted materials, and volume loading applications such as mass-excavation applications in ideal conditions. Smaller buckets are recommended for adverse conditions such as off-level applications, rocks, and uneven surfaces. Bucket capacity indicated is SAE heaped.

# Additional equipment

Key: ● Standard ▲ Optional or special

See your John Deere dealer for further information.

<b>345G Engine</b>
● Auto-idle system
● Automatic belt-tension device
● Batteries (2 – 12 volt)
● Coolant recovery tank
● Dual-element dry-type air filter
● Electronic engine control
● Enclosed fan guard (conforms to SAE J1308)
● Engine coolant to –37 deg. C (–34 deg. F)
● Programmable auto shutdown
● Fuel filter with water separator
● Full-flow oil filter
● Turbocharger with charge air cooler
● Cool-on-demand hydraulic-driven, suction-type fan with remote-mounted drive and enclosed fan guard
● 500-hour engine-oil-change interval
● 70% (35 deg.) off-level capability
▲ Engine-oil-sampling valve
▲ Severe-duty fuel filter
<b>Hydraulic System</b>
● Reduced-drift valve for boom down, arm in
● Auxiliary hydraulic valve section
● Spring-applied, hydraulically released automatic swing brake
● Auxiliary hydraulic-flow adjustments through monitor
● Auto power lift
● 5,000-hour hydraulic-oil-change interval
● Auxiliary hydraulic lines with proportional control on right-hand pilot lever
▲ Hydraulic-oil-sampling valve
▲ Hydraulic filter restriction indicator kit
▲ Load-lowering control
▲ Single-pedal propel control
▲ Control pattern change valve
<b>Undercarriage</b>
● Planetary drive with axial piston motors
● Propel motor shields
● Spring-applied, hydraulically released automatic propel brake
● Track guides, front idler and 3 additional
● 2-speed propel with automatic shift
● Upper carrier rollers (2)
● Sealed and lubricated track chain
▲ Triple semi-grouser shoes, 800 mm (32 in.)

<b>345G Upperstructure</b>
● Right-hand, left-hand, and counterweight mirrors
● Vandal locks with ignition key: Cab door / Service doors / Toolbox
● Debris screening
● Service handrails
● Remote-mounted engine oil and fuel filters
<b>Front Attachments</b>
● Centralized lubrication system
● Dirt seals on all bucket pins
● Oil-impregnated bushings
● Reinforced resin thrust plates
● Tungsten carbide thermal coating on arm-to-bucket joint
▲ Arm, 3.11 m (10 ft. 2 in.)
▲ Arm, 3.76 m (12 ft. 4 in.)
▲ Attachment quick-couplers
▲ Buckets: Heavy duty / Heavy-duty high capacity / Side cutters and teeth
▲ Material clamps
<b>Operator's Station</b>
● Adjustable independent-control positions (levers-to-seat, seat-to-pedals)
● AM/FM radio
● Auto climate control/air conditioner/heater/pressurizer
● Built-in Operator's Manual storage compartment and manual
● Cell-phone power outlet, 12 volt, 60 watt, 5 amp
● Coat hook
● Deluxe suspension cloth seat with 100-mm (4 in.) adjustable armrests
● Floor mat
● Front windshield wiper with intermittent speeds
● Gauges (illuminated): Diesel Exhaust Fluid (DEF) / Engine coolant / Fuel
● Horn, electric
● Hour meter, electric
● Hydraulic shutoff lever, all controls
● Hydraulic warm-up control
● Interior light
● Large cup holder

<b>345G Operator's Station (continued)</b>
● Machine Information Center (MIC)
● Mode selectors (illuminated): Power modes (3) / Travel modes (2 with automatic shift) / Work mode (1)
● Multifunction, color LCD monitor with: Diagnostic capability / Multiple-language capabilities / Maintenance tracking / Clock / System monitoring with alarm features: Auto-idle indicator, engine air cleaner restriction indicator light, engine check, engine coolant temperature indicator light with audible alarm, engine oil pressure indicator light with audible alarm, low-alternator-charge indicator light, low-fuel indicator light, low DEF indication with audible alarm, fault code alert indicator, fuel-rate display, wiper-mode indicator, work-lights-on indicator, and work-mode indicator
● Motion alarm with cancel switch (conforms to SAE J994)
● Power-boost switch on right console lever
● SAE 2-lever control pattern
● Seat belt, 76 mm (3 in.), retractable
● Tinted glass
● Transparent tinted overhead hatch
● Hot/cold beverage compartment
● Air-suspension heated seat
▲ Protection screens for cab front, rear, and side
▲ Window vandal-protection covers
<b>Electrical</b>
● 50-amp alternator
● Blade-type multi-fused circuits
● Positive-terminal battery covers
● Battery-disconnect switch
● JDLink™ wireless communication system (available in specific countries; see your dealer for details)
● Rearview camera
▲ Left and right side-view cameras with additional monitor
<b>Lights</b>
● Work lights: 3 halogen (1 mounted on frame, 2 mounted on boom)
▲ 2 lights on front of cab / 1 rear cab light

Net engine power is with standard equipment including air cleaner, exhaust system, alternator, and cooling fan, at test conditions specified per ISO 9249. No derating is required up to 3050-m (10,000 ft.) altitude. Specifications and design subject to change without notice. Wherever applicable, specifications are in accordance with SAE standards. Except where otherwise noted, these specifications are based on a unit with 1.25-m<sup>3</sup> (1.63 cu. yd.), 1067-mm (42 in.), 957-kg (2,110 lb.) bucket; 3.76-m (12 ft. 4 in.) arm; 8680-kg (19,136 lb.) counterweight, 800-mm (32 in.) triple semi-grouser shoes, full fuel tank, and 79-kg (175 lb.) operator.

