

# 190G W/230G W

19 960–24 140-kg (44,000–53,220 lb.) Operating Weight



**JOHN DEERE**



# The wheel deal.

Looking to get on a roll? 190G W and 230G W Wheeled Excavators travel on tires, so they're more mobile and maneuverable than tracked excavators. Their more spacious and comfortable cabs come equipped with easy-to-navigate enhanced LCD monitors that let operators easily dial-in a wealth of machine info and functionality. Rugged EPA Interim Tier 4 (IT4)/EU Stage IIIB diesels meet rigid emission regulations, enabling you to work, wherever there's work. Delivering the smoothness, control, and operating ease you've come to expect from John Deere, these wheeled excavators are the real deal.



Key Specifications	190G W	230G W
Net Peak Power (ISO 9249)	119 kW (159 hp)	119 kW (159 hp)
Operating Weight	20 550 kg (45,300 lb.)*	24 140 kg (53,220 lb.)*
Digging Depth	5.93 m (19 ft. 5 in.)	6.14 m (20 ft. 2 in.)
Arm Force (ISO)	91 kN (20,458 lb.)	114 kN (25,628 lb.)
Maximum Travel Speed	35 km/h (21.7 mph)	27.5 km/h (17.1 mph)

\*With two-piece boom and front and rear outriggers.



John Deere WorkSight™ is a powerful suite of telematics solutions that optimizes machines, uptime, and jobsites. At its heart, JDLink™ monitoring provides real-time machine-location and -utilization data, and enables machine-health prognostics that suggest maintenance solutions to prevent costly downtime.

Choose from a variety of boom, blade, outrigger, and bucket options to equip your machine exactly as needed to optimize your setup.

Spacious cab delivers excellent visibility and less noise, along with a bevy of creature comforts.

The IT4/Stage IIIB technology utilized in our diesel engine is simple, fuel efficient, fully integrated, and fully supported. Seamless solutions that require no operator input or loss of productivity include field-proven cooled exhaust gas recirculation (EGR) for reducing NO<sub>x</sub>, and a diesel particulate filter (DPF) and diesel oxidation catalyst (DOC) to reduce particulate matter.

Rubber tires allow you to drive quickly from job to job instead of loading up a trailer — plus they're much friendlier to paved surfaces.

The G-Series' short wheelbase makes them very adept in close quarters — unlike unwieldy truck-mounted excavators. For work close-up, opt for the two-piece boom.

Multi-language LCD monitor and rotary dial provide intuitive access to a wealth of information and functions.

# Streetwise.

Work has never been easier than with John Deere wheeled excavators. They're the perfect "Swiss Army knife" for a variety of work, whether it's clearing ditches, repairing sewers or potholes, loading trucks, or moving Jersey barriers. Rubber tires and transport speeds as fast as 35 km/h (21.7 mph) mean you don't need to load them on a trailer to travel to a nearby job or across pavement. Plenty of street smarts, too, with the Powerwise III™ engine/hydraulic-management system, three productivity modes, and Power Dig and Auto Power Lift functions. Add any of the many available options to tackle a wide variety of on- and off-road work.



When the digging gets tough, press the Power Dig button for the extra hydraulic power you need to muscle through. Need a little extra lift when craning? Auto Power Lift automatically engages when the boom is raised.

Powerwise III perfectly balances engine performance and hydraulic flow for predictable operation. Three productivity modes allow you to choose the digging style that fits the job. **High productivity** delivers more power and faster hydraulic response to move more material. **Power** delivers smooth and balanced metering for normal operation. **Economy** reduces top speed and helps save fuel.

Impressive horsepower, weight, and dig forces make these machines highly productive for a wide variety of work.

Activate the axle-lock switch on the steering column to hold the machine more steady while digging or handling material when the stabilizers are not in use. Engage the brake at the same time to add even more stability.

Fast travel speed and boom and arm movement combined with superior arm force help speed cycle times. Wide axles, rock-solid stability, and substantial lift capabilities allow these machines to quickly move Jersey barriers.

Low-flow assist hydraulics come standard, perfect for lower-pressure, lower-flow applications like bucket-tilt or -swinger attachments. Need additional hydraulic capability? Dealer-installed high-pressure, high-flow auxiliary hydraulic packages are available.

Standard deluxe lighting package provides 360-deg. illumination of the work area so you can extend the workday beyond daylight hours.

If you don't need a blade, choose the four-outrigger option for maximum stability. You can activate the outriggers together or independently to quickly and easily level the machine.



1. Refined parallelogram blade better handles backfill and cleanup duties, while serving as a third stabilizer during digging.

2. Monoblock boom delivers the reach and lift capacity you need for long-distance work. Or opt for a two-piece boom for added versatility.

3. Standard solid-rubber spacer between the heavy-duty dual tires puts pressure on the sidewalls to help keep the machine more stable. It also keeps mud and debris out, for longer tire life.



# Tap into your full potential.

Operators will have no trouble “dialing it up a notch” in this spacious, well-appointed cab. The refined monitor employs a rotary control that operators can simply turn and tap to access an abundance of performance and convenience functions and features. Operators will also appreciate the comfortable fabric-covered high-back seat, unsurpassed all-round visibility, low-effort joysticks, a highly efficient HVAC system, and numerous other amenities. The 190G W and 230G W provide everything your operators need to do their best work.

Generous hydraulic flow and smooth, predictable metering ensure powerful digging force, precise low-effort control, and superb multifunction operation. Quick, responsive pump activation eliminates any delay in functions.

Wide expanse of front and side glass, narrow front cab posts, large overhead glass, and numerous mirrors provide virtually unobstructed all-around visibility. If you need to see more, the standard rearview camera displays the action behind on the monitor.

We’ve got your back with a sculpted mechanical-suspension high-back seat. Seat has 318 mm (12.5 in.) of travel, sliding together or independent of the joystick console. So it won’t cramp an operator’s style.

Two-speed PowerShift™ transmission shifts smoothly on-the-go from low to high in each speed, enabling multiple operating speeds for better responsiveness. Downshifting isn’t a problem either, since the transmission will only shift within certain travel-speed parameters — protecting both operator and drivetrain.

Multi-language LCD monitor provides intuitive access to a wealth of information and functions. Simply turn and tap the rotary dial to select work mode, access operating info, check maintenance intervals, source diagnostic codes, adjust cab temperature, and tune the radio. Plus much more.



1. The F-N-R directional switch is now conveniently located on the left-hand pilot lever, making it easier to control the blade and stabilizer functions.

2. Ergonomically correct short-throw pilot levers provide smooth, predictable fingertip control with less movement or effort. Pushbuttons in the right lever allow fingertip control of auxiliary hydraulic flow for operating attachments.

3. Each outrigger is independently controlled, enabling optimum placement to help complete the job safely and surely.

4. Automatic, high-velocity bi-level climate-control system with automotive-style adjustable louvers helps keep the glass clear and the cab comfortable.



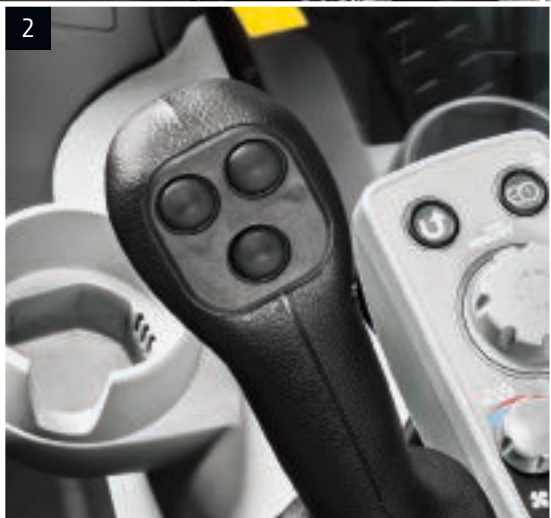



# Nothing runs like a Deere, because nothing is built like one.

Don't let downtime get you down. From their ultra-dependable, fuel-sipping diesels to their rugged D-channel side frames, these wheeled excavators keep things upbeat — and up and running. Their highly efficient cooling system ensures things are running cool in any environment. You'll also continue to profit from traditional durability-enhancing features, including tungsten-carbide thermal-coated arm surfaces, oil-impregnated bushings, and welded boom bulkheads. For maximum uptime and long-term durability. When you know how they're built, you'll run a Deere.





A John Deere exclusive, three welded bulkheads within the boom resist torsional stress for unsurpassed durability. Booms, arms, and mainframes are so tough, they're warranted for three years or 10,000 hours.

Highly efficient, heavy-duty cooling system keeps things cool, even in the toughest environments.

Oil-impregnated bushings enhance durability and extend grease intervals to 500 hours for the arm-and-boom joint and 100 hours for the bucket joint.

PowerShift transmission has been integrated with the axle and repositioned higher above ground level to better protect it from damage.

Wet-type disc brakes are virtually maintenance free and deliver reliable, long-term stopping power.

1. Heavy-duty covers on the oversize outriggers help prevent damage to the hydraulic cylinders.

2. Large chassis beams, swing bearings, and boom-foot areas deliver rock-solid durability.

3. Tungsten-carbide coating creates an extremely wear-resistant surface to protect the all-important bucket-to-arm joint.

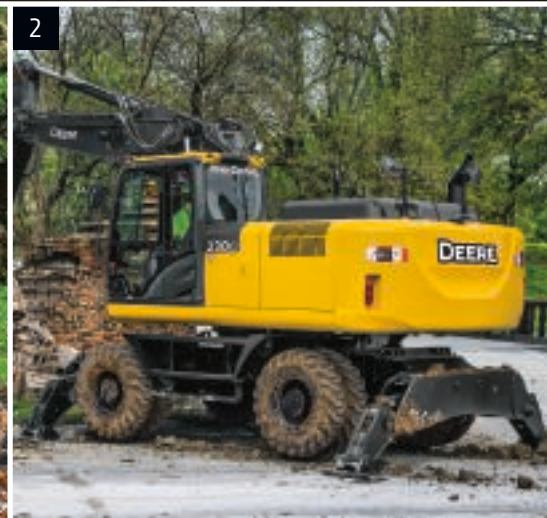

1

2

3

# Let's roll.

G-Series Wheeled Excavators are loaded with features that make them hassle-free to service and maintain, so you can keep things rolling. Large, easy-to-open doors and easy-access service points make quick work of the daily routine. Remote-mounted vertical oil and fuel filters minimize maintenance. And extended engine and hydraulic fluid-service intervals increase uptime and reduce daily operating costs. Plus the Machine Information Center (MIC), state-of-the-art LCD color monitor, and fluid-sample ports help you make timely decisions about machine upkeep — and manage uptime and costs.

Auto-idle automatically reduces engine speed when hydraulics aren't in use. Auto-shutdown further preserves precious fuel.

MIC captures and stores vital machine performance and utilization data to help improve uptime.

Large fuel tanks and 500- and 5,000-hour engine and hydraulic oil-service intervals decrease downtime for routine maintenance.

Ground-level fresh-air cab filter is quickly serviced from outside the cab where it's more likely to get done.

Reinforced resin thrust plates, grooved bushings, and thermal-coated bucket joints increase arm, boom, and bucket lube intervals to 500 hours.

Ultimate Uptime, featuring John Deere WorkSight™, is a customizable support solution available exclusively from your Deere dealer. This flexible offering maximizes equipment availability with standard John Deere WorkSight capabilities that can help prevent future downtime and speed repairs when they do occur. In addition to the base John Deere WorkSight features, our dealers work with you to build an uptime package that meets the specific needs of your machine, fleet, project, and business, including customized maintenance and repair agreements, onsite parts availability, extended warranties, fluid sampling, response-time guarantees, and more.



1. Easy-to-read LCD monitor tracks scheduled maintenance intervals and issues reminders. Should a problem arise, it provides diagnostic information to help decrease downtime.
2. Swing open the side panels on either side of the machine to provide even more wide-open access to components.

3. Fuel coolers and A/C condensers swing out, simplifying clean-out. Side-by-side coolers provide easy access.
4. Vertical spin-on engine oil filters and fuel/water separators are conveniently grouped in the right rear compartment, for easy ground-level servicing.



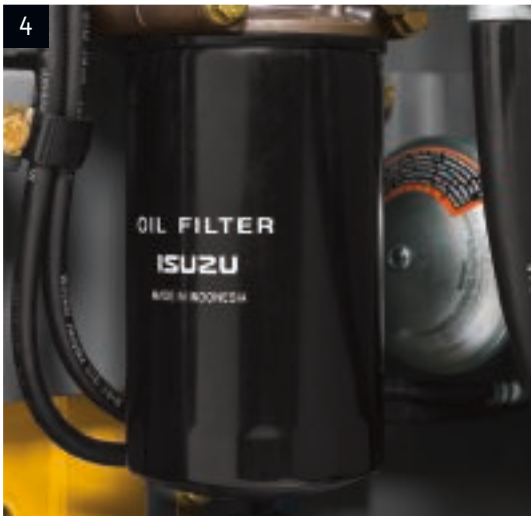

# 190G W



<b>Engine</b>		<b>190G W</b>	
Manufacturer and Model	Isuzu 4HK1		
Non-Road Emission Standard	EPA Interim Tier 4/EU Stage IIIB		
Cylinders	4		
Displacement	5.2 L (317 cu. in.)		
Net Peak Power (ISO 9249)	119 kW (159 hp) at 2,000 rpm		
Off-Level Capacity	67% (34 deg.)		
Aspiration	Turbocharged, air-to-air charge-air cooler		
<b>Cooling</b>		High-efficiency, direct-drive suction-type fan	
<b>Powertrain</b>		2-speed propel with creeper mode and automatic shift	
<b>Maximum Travel Speed</b>			
Creeper	2.6 km/h (1.6 mph)		
Low	8.6 km/h (5.3 mph)		
High	35.0 km/h (21.8 mph)		
<b>Front Axle</b>		All-wheel drive; can be locked hydraulically in any position	
Oscillation	± 7 deg.		
<b>Brakes</b>		Maintenance-free wet-disc brakes on front and rear axles; fully hydraulic service brakes	
<b>Tires</b>		Standard size, dual-traction-type 10.00-20 14PR tires	
Drawbar Pull	9534 kgf (20,570 lbf)		
<b>Hydraulics</b>			
<b>Main Pumps</b>		2 variable-displacement axial-piston pumps	
Pump Flow, Maximum x 2	165 L/min. (43.6 gpm)		
<b>System Operating Pressure</b>			
Implement Circuits	34 300 kPa (4,975 psi)		
Travel Circuits	34 800 kPa (5,047 psi)		
Swing Circuits	33 400 kPa (4,844 psi)		
Power Boost	36 300 kPa (5,265 psi)		
<b>Controls</b>		Pilot levers, short stroke, low-effort hydraulic pilot controls with shutoff lever	
<b>Cylinders</b>			
	<i>Bore</i>	<i>Rod Diameter</i>	<i>Stroke</i>
<b>Monoblock Boom (2)</b>	120 mm (4.7 in.)	85 mm (3.4 in.)	1050 mm (41.3 in.)
<b>2-Piece Boom (2)</b>	120 mm (4.7 in.)	85 mm (3.4 in.)	980 mm (38.6 in.)
<b>Positioning, 2-Piece Boom (1)</b>	170 mm (6.7 in.)	105 mm (4.1 in.)	670 mm (26.4 in.)
<b>Arm (1)</b>	125 mm (4.9 in.)	90 mm (3.5 in.)	1371 mm (54.0 in.)
<b>Bucket (1)</b>	105 mm (4.1 in.)	75 mm (3.0 in.)	1060 mm (41.7 in.)
<b>Electrical</b>			
Voltage	24 volt		
Number of Batteries (12 volt)	2		
Alternator Rating	50 amp		
<b>Lights (6)</b>		Headlights (2), top of cab (2), rear of cab (1), and boom (1)	
<b>Driving Lights</b>		Headlights (2), turn signals and hazard lights, brake lights, and side marker lights	
<b>Swing Mechanism</b>			
Speed	12.2 rpm		
Torque	53 000 Nm (39,091 lb.-ft.)		
<b>Serviceability</b>			
<b>Refill Capacities</b>			
Fuel Tank	290 L (76.6 gal.)		
Engine Coolant	25 L (6.6 gal.)		
Engine Oil with Filter	23 L (6.1 gal.)		
Hydraulic Tank	100 L (26.4 gal.)		
Hydraulic System	180 L (47.6 gal.)		
Swing Drive	6.2 L (6.6 qt.)		
Transmission	2.5 L (2.6 qt.)		



**Serviceability (continued) 190G W**

**Refill Capacities (continued)**

Differential Gear	
Front	9.5 L (2.5 gal.)
Rear	14 L (3.7 gal.)
Front and Rear Hubs	2.5 L x 2 (2.6 qt. x 2)

**Operating Weights**

With full fuel tank; 79-kg (175 lb.) operator; 0.7-m<sup>3</sup> (0.92 cu. yd.), 900-mm (35 in.), 610-kg (1,345 lb.) bucket; 2.71-m (8 ft. 11 in.) arm; standard gauge; and 4000-kg (8,819 lb.) counterweight

	Monoblock Boom	2-Piece Boom
Front Outrigger and Rear Outrigger	20 200 kg (44,530 lb.)	20 550 kg (45,300 lb.)
Front Blade and Rear Outrigger	19 960 kg (44,000 lb.)	20 310 kg (44,780 lb.)

**Operating Dimensions**

	Monoblock Boom	2-Piece Boom
Arm Digging Force		
SAE	87 kN (19,558 lb.)	87 kN (19,558 lb.)
ISO	91 kN (20,458 lb.)	91 kN (20,458 lb.)
Bucket Digging Force		
SAE	107 kN (24,055 lb.)	107 kN (24,055 lb.)
ISO	123 kN (27,651 lb.)	123 kN (27,651 lb.)
<b>A</b> Maximum Reach	9.58 m (31 ft. 5 in.)	9.48 m (31 ft. 1 in.)
<b>B</b> Maximum Digging Depth	5.83 m (19 ft. 2 in.)	5.93 m (19 ft. 5 in.)
<b>C</b> Maximum Cutting Height	9.25 m (30 ft. 4 in.)	9.85 m (32 ft. 4 in.)
<b>D</b> Maximum Dumping Height	6.45 m (21 ft. 2 in.)	6.95 m (22 ft. 10 in.)
<b>E</b> Overall Height	3.13 m (10 ft. 3 in.)	3.21 m (10 ft. 6 in.)
<b>F</b> Overall Length		
Front Outrigger and Rear Outrigger	9.54 m (31 ft. 4 in.)	9.36 m (30 ft. 9 in.)
Front Blade and Rear Outrigger	9.48 m (31 ft. 1 in.)	9.30 m (30 ft. 6 in.)
<b>G</b> Minimum Swing Radius	3.48 m (11 ft. 5 in.)	3.00 m (9 ft. 10 in.)

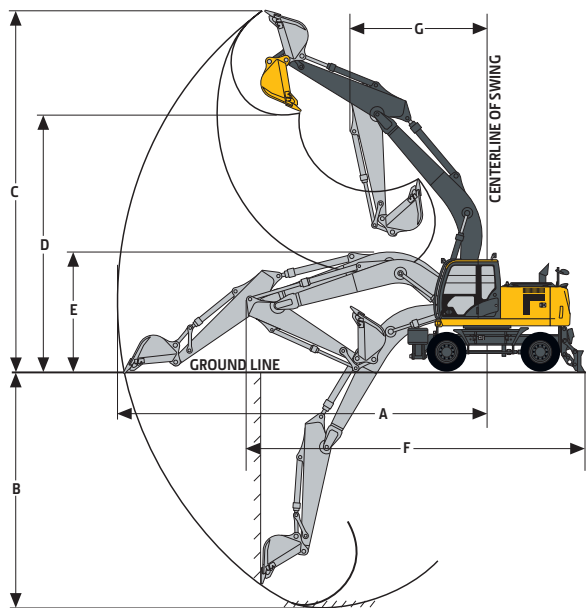

**190G W EXCAVATOR WITH MONOBLOCK BOOM**

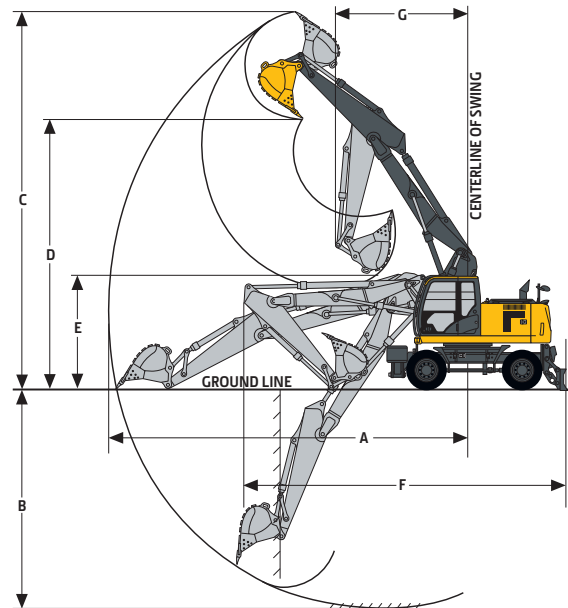

**190G W EXCAVATOR WITH 2-PIECE BOOM**

**Machine Dimensions**

**190G W**

With standard gauge and 2.71-m (8 ft. 11 in.) arm; dimensions are provided for both the front and rear outrigger configuration, and for the front blade and rear outrigger configuration

	<i>Monoblock Boom</i>	<i>2-Piece Boom</i>
<b>A</b> Overall Length	8.98 m (29 ft. 6 in.)	—
<b>A'</b> Overall Length	—	8.80 m (28 ft. 10 in.)
<b>B</b> Overall Height	3.13 m (10 ft. 3 in.)	—
<b>B'</b> Overall Height	—	3.21 m (10 ft. 6 in.)
<b>C</b> Rear-End Swing Radius	2.32 m (7 ft. 7 in.)	2.32 m (7 ft. 7 in.)
<b>D</b> Engine Cover Height	2.48 m (8 ft. 2 in.)	2.48 m (8 ft. 2 in.)
<b>E</b> Counterweight Clearance	1.24 m (4 ft. 1 in.)	1.24 m (4 ft. 1 in.)
<b>F</b> Overall Width of Upperstructure	2.45 m (8 ft. 0 in.)	2.45 m (8 ft. 0 in.)
<b>G</b> Overall Height of Cab	3.13 m (10 ft. 3 in.)	3.13 m (10 ft. 3 in.)
<b>H</b> Overall Width of Tires	2.55 m (8 ft. 4 in.)	2.55 m (8 ft. 4 in.)
<b>J</b> Minimum Ground Clearance	0.35 m (13.8 in.)	0.35 m (13.8 in.)
<b>K</b> Wheelbase	2.65 m (8 ft. 8 in.)	2.65 m (8 ft. 8 in.)
<b>L</b> Swing Center to Rear Axle	1.15 m (3 ft. 9 in.)	1.15 m (3 ft. 9 in.)
<b>M</b> Front Overhang		
Front Outrigger and Rear Outrigger	1.38 m (4 ft. 6 in.)	1.38 m (4 ft. 6 in.)
Front Blade and Rear Outrigger	1.32 m (4 ft. 4 in.)	1.32 m (4 ft. 4 in.)
<b>N</b> Rear Overhang	1.09 m (3 ft. 7 in.)	1.09 m (3 ft. 7 in.)
<b>O</b> Maximum Blader Lower	0.22 m (8.7 in.)	0.22 m (8.7 in.)
<b>P</b> Overall Height of Blade	0.59 m (23.2 in.)	0.59 m (23.2 in.)
<b>Q</b> Maximum Blade Raise	0.37 m (14.6 in.)	0.37 m (14.6 in.)
<b>R</b> Overall Width of Blade	2.53 m (8 ft. 4 in.)	2.53 m (8 ft. 4 in.)
<b>S</b> Overall Width with Outrigger Retracted	2.47 m (8 ft. 1 in.)	2.47 m (8 ft. 1 in.)
<b>T</b> Overall Width with Outrigger Extended	3.44 m (11 ft. 3 in.)	3.44 m (11 ft. 3 in.)
<b>V</b> Overall Height of Boom (traveling)	4.00 m (13 ft. 1 in.)	4.00 m (13 ft. 1 in.)
<b>W</b> Front Overhang (traveling)	3.33 m (10 ft. 11 in.)	3.33 m (10 ft. 11 in.)

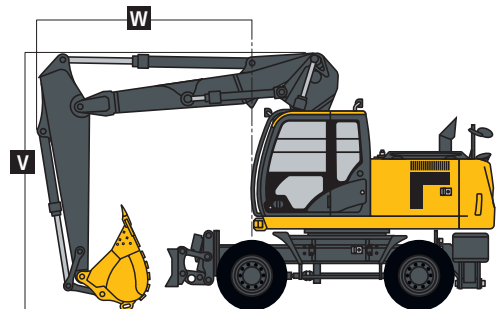
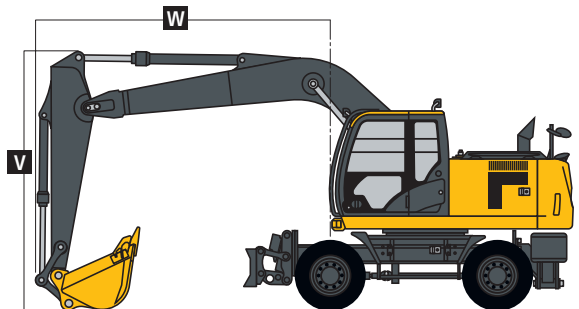
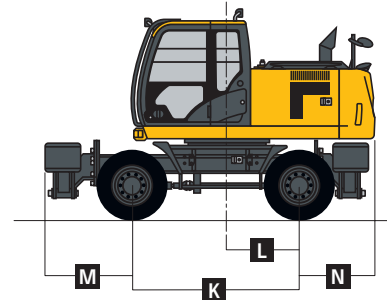
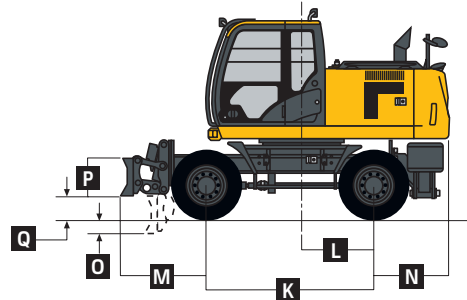
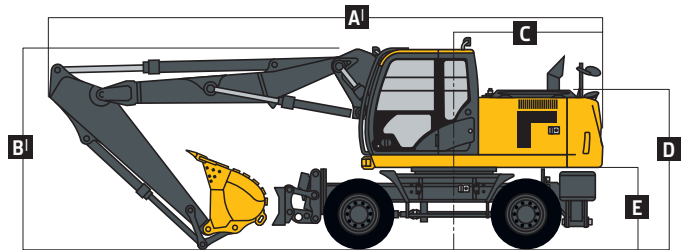
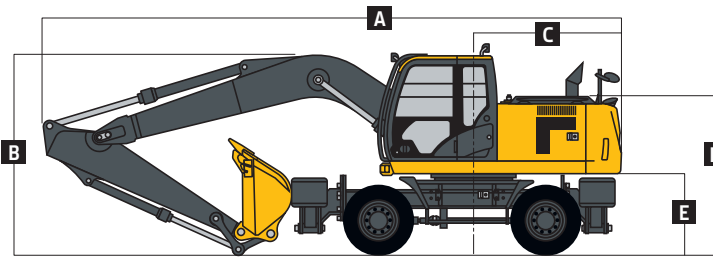
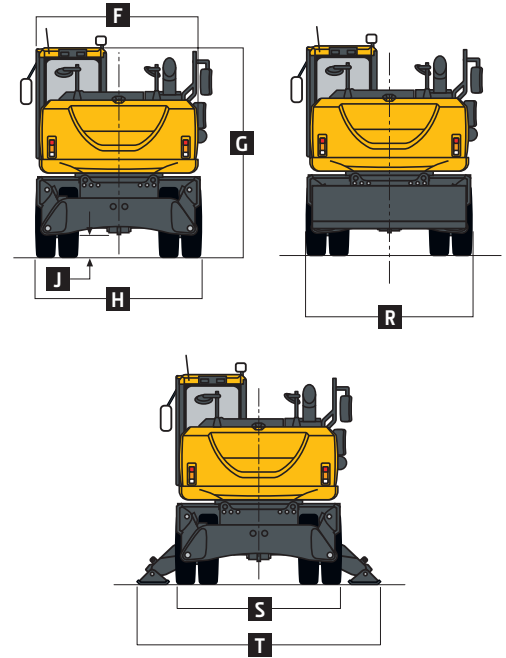

**Lift Capacities 190G W**

**Boldface type** indicates hydraulically limited capacities; lightface type indicates stability-limited capacities, in kg (lb.). Ratings at bucket lift hook; machine equipped with 600-kg (1,323 lb.) bucket, 2.71-m (8 ft. 11 in.) arm, and standard counterweight; and situated on firm, level, uniform supporting surface. Figures do not exceed 87% of hydraulic capacity or 75% of weight needed to tip machine.

Load Point Height	1.5 m (5 ft.)		3.0 m (10 ft.)		4.5 m (15 ft.)		6.0 m (20 ft.)		7.5 m (25 ft.)	
Horizontal Distance from Centerline of Rotation	Over Front	Over Side	Over Front	Over Side	Over Front	Over Side	Over Front	Over Side	Over Front	Over Side
<i>With monoblock boom, rear outriggers, and front blade down</i>										
6.0 m (20 ft.)							<b>4420</b>	<b>4420</b>		
							<b>(9,420)</b>	<b>(9,420)</b>		
4.5 m (15 ft.)					<b>6430</b>	<b>6430</b>	<b>5320</b>	4730	<b>3330</b>	3170
					<b>(13,740)</b>	<b>(13,740)</b>	<b>(11,560)</b>	(10,160)		
3.0 m (10 ft.)					<b>7910</b>	7280	<b>5930</b>	4520	4730	3090
					<b>(17,040)</b>	(15,660)	<b>(12,850)</b>	(9,730)	<b>(9,870)</b>	(6,630)
1.5 m (5 ft.)					<b>9060</b>	6820	<b>6470</b>	4310	4620	3000
					<b>(19,570)</b>	(14,670)	<b>(14,010)</b>	(9,280)	(9,930)	(6,440)
Ground Line					<b>9290</b>	6580	6530	4170	4550	2930
			<b>(9,010)</b>	<b>(9,010)</b>	<b>(20,130)</b>	<b>(14,140)</b>	(14,030)	<b>(8,960)</b>	(9,770)	(6,290)
-1.5 m (-5 ft.)			<b>7920</b>	<b>7920</b>	<b>8650</b>	6520	<b>6300</b>	4110		
			<b>(18,050)</b>	<b>(18,050)</b>	<b>(18,740)</b>	(14,000)	<b>(13,600)</b>	(8,840)		
-3.0 m (-10 ft.)			<b>9560</b>	<b>9560</b>	<b>7140</b>	6590	<b>5100</b>	4150		
			<b>(20,680)</b>	<b>(20,680)</b>	<b>(15,380)</b>	(14,150)	<b>(10,810)</b>	(8,950)		
<i>With monoblock boom and 4 outriggers down</i>										
6.0 m (20 ft.)							<b>4420</b>	<b>4420</b>		
							<b>(9,420)</b>	<b>(9,420)</b>		
4.5 m (15 ft.)					<b>6430</b>	<b>6430</b>	<b>5320</b>	<b>5320</b>	<b>3330</b>	<b>3330</b>
					<b>(13,740)</b>	<b>(13,740)</b>	<b>(11,560)</b>	<b>(11,560)</b>		
3.0 m (10 ft.)					<b>7910</b>	<b>7910</b>	<b>5930</b>	5280	<b>4870</b>	3620
					<b>(17,040)</b>	<b>(17,040)</b>	<b>(12,850)</b>	(11,350)	<b>(9,870)</b>	(7,760)
1.5 m (5 ft.)					<b>9060</b>	8100	<b>6470</b>	5060	4830	3520
					<b>(19,570)</b>	(17,410)	<b>(14,010)</b>	(10,890)	(10,370)	(7,560)
Ground Line					<b>9290</b>	7850	<b>6660</b>	4910	4750	3450
			<b>(9,010)</b>	<b>(9,010)</b>	<b>(20,130)</b>	(16,850)	<b>(14,420)</b>	(10,560)	(10,210)	(7,410)
-1.5 m (-5 ft.)			<b>7920</b>	<b>7920</b>	<b>8650</b>	7780	<b>6300</b>	4850		
			<b>(18,050)</b>	<b>(18,050)</b>	<b>(18,740)</b>	(16,700)	<b>(13,600)</b>	(10,430)		
-3.0 m (-10 ft.)			<b>9560</b>	<b>9560</b>	<b>7140</b>	<b>7140</b>	<b>5100</b>	4900		
			<b>(20,680)</b>	<b>(20,680)</b>	<b>(15,380)</b>	<b>(15,380)</b>	<b>(10,810)</b>	(10,550)		
<i>With 2-piece boom, rear outriggers, and front blade down</i>										
6.0 m (20 ft.)							<b>3980</b>	<b>3980</b>		
							<b>(8,790)</b>	<b>(8,790)</b>		
4.5 m (15 ft.)					<b>4860</b>	<b>4860</b>	<b>4330</b>	<b>4330</b>	<b>2820</b>	<b>2820</b>
					<b>(10,510)</b>	<b>(10,510)</b>	<b>(9,450)</b>	<b>(9,450)</b>		
3.0 m (10 ft.)			<b>8700</b>	<b>8700</b>	<b>6500</b>	<b>6500</b>	<b>5050</b>	4710	<b>4430</b>	3210
			<b>(19,130)</b>	<b>(19,130)</b>	<b>(13,970)</b>	<b>(13,970)</b>	<b>(10,960)</b>	(10,130)	<b>(8,980)</b>	<b>(6,840)</b>
1.5 m (5 ft.)			<b>10 630</b>	<b>10 630</b>	<b>8100</b>	7210	<b>5830</b>	4670	4740	3140
			<b>(23,330)</b>	<b>(23,330)</b>	<b>(17,470)</b>	(15,500)	<b>(12,630)</b>	(10,070)	(10,190)	(6,700)
Ground Line	<b>8670</b>	<b>8670</b>	12 770	12 770	9010	7250	<b>6400</b>	4710	4670	3030
	<b>(19,420)</b>	<b>(19,420)</b>	<b>(28,000)</b>	<b>(28,000)</b>	<b>(19,490)</b>	(15,600)	<b>(13,860)</b>	(10,070)	(9,980)	(6,460)
-1.5 m (-5 ft.)	<b>13 900</b>	<b>13 900</b>	<b>14 840</b>	<b>14 660</b>	<b>9230</b>	7490	<b>6610</b>	4460		
	<b>(31,210)</b>	<b>(31,210)</b>	<b>(32,210)</b>	<b>(31,430)</b>	<b>(19,990)</b>	(16,090)	<b>(14,310)</b>	(9,530)		
-3.0 m (-10 ft.)	<b>22 710</b>	<b>22 710</b>	<b>15 310</b>	<b>15 260</b>	<b>9590</b>	7130	<b>6220</b>	4280		
	<b>(51,650)</b>	<b>(51,650)</b>	<b>(33,190)</b>	<b>(33,000)</b>	<b>(20,730)</b>	(15,250)	<b>(13,080)</b>	(9,170)		

**Lift Capacities (continued) 190G W**

**Boldface type** indicates hydraulically limited capacities; **lightface type** indicates stability-limited capacities, in kg (lb.). Ratings at bucket lift hook; machine equipped with 600-kg (1,323 lb.) bucket, 2.71-m (8 ft. 11 in.) arm, and standard counterweight; and situated on firm, level, uniform supporting surface. Figures do not exceed 87% of hydraulic capacity or 75% of weight needed to tip machine.

Load Point Height	1.5 m (5 ft.)		3.0 m (10 ft.)		4.5 m (15 ft.)		6.0 m (20 ft.)		7.5 m (25 ft.)	
	Over Front	Over Side	Over Front	Over Side	Over Front	Over Side	Over Front	Over Side	Over Front	Over Side
<i>Horizontal Distance from Centerline of Rotation</i>										
<i>With 2-piece boom and 4 outriggers down</i>										
6.0 m (20 ft.)							<b>3980</b> (8,790)	<b>3980</b> (8,790)		
4.5 m (15 ft.)					<b>4860</b> (10,510)	<b>4860</b> (10,510)	<b>4330</b> (9,450)	<b>4330</b> (9,450)	<b>2820</b>	<b>2820</b>
3.0 m (10 ft.)			<b>8700</b> (19,130)	<b>8700</b> (19,130)	<b>6500</b> (13,970)	<b>6500</b> (13,970)	<b>5050</b> (10,960)	<b>5050</b> (10,960)	<b>4430</b> (8,980)	<b>3730</b> (7,970)
1.5 m (5 ft.)			<b>10 630</b> (23,330)	<b>10 630</b> (23,330)	<b>8100</b> (17,470)	<b>8100</b> (17,470)	<b>5830</b> (12,630)	<b>5310</b> (11,430)	<b>4770</b> (10,390)	<b>3660</b> (7,820)
Ground Line	<b>8670</b> (19,420)	<b>8670</b> (19,420)	<b>12 770</b> (28,000)	<b>12 770</b> (28,000)	<b>9010</b> (19,490)	<b>8280</b> (17,820)	<b>6400</b> (13,860)	<b>5370</b> (11,600)	<b>4860</b> (10,410)	<b>3560</b> (7,610)
-1.5 m (-5 ft.)	<b>13 900</b> (31,210)	<b>13 900</b> (31,210)	<b>14 840</b> (32,210)	<b>14 840</b> (32,210)	<b>9230</b> (19,990)	<b>8490</b> (18,300)	<b>6610</b> (14,310)	<b>5230</b> (11,190)		
-3.0 m (-10 ft.)	<b>22 710</b> (51,650)	<b>22 710</b> (51,650)	<b>15 310</b> (33,190)	<b>15 310</b> (33,190)	<b>9590</b> (20,730)	<b>8450</b> (18,070)	<b>6220</b> (13,080)	<b>5040</b> (10,810)		



**Buckets 190G W**

A full line of buckets is offered to meet a wide variety of applications. Digging forces are with power boost. Buckets are equipped with John Deere TK-Series Bucket Teeth standard. Replaceable cutting edges and a variety of teeth are available through John Deere Parts. Optional side cutters add 150 mm (6 in.) to bucket widths. Capacities are SAE heaped ratings.

Type Bucket	Bucket Width		Bucket Capacity		Bucket Weight		Bucket Dig Force		Arm Dig Force, 2.71 m (8 ft. 11 in.)		Bucket Tip Radius		Number of Teeth
	mm	in.	m <sup>3</sup>	cu. yd.	kg	lb.	kN	lb.	kN	lb.	mm	in.	
General-Purpose High-Capacity	762	30	0.60	0.79	650	1,432	122.7	27,582	91.2	20,512	1473	58.00	4
	914	36	0.76	1.00	735	1,621	122.7	27,582	91.2	20,512	1473	58.00	5
	1067	42	0.93	1.22	812	1,790	122.7	27,582	91.2	20,512	1473	58.00	5
	1219	48	1.09	1.43	896	1,976	122.7	27,582	91.2	20,512	1473	58.00	6
Heavy-Duty	610	24	0.40	0.52	543	1,197	123.6	27,780	91.5	20,563	1463	57.61	4
	762	30	0.54	0.71	621	1,369	123.5	27,768	91.5	20,561	1463	57.61	4
	914	36	0.69	0.90	707	1,559	123.5	27,768	91.5	20,561	1463	57.61	5
	1067	42	0.83	1.09	785	1,731	123.5	27,768	91.5	20,561	1463	57.61	5
	1219	48	0.99	1.29	871	1,921	123.5	27,768	91.5	20,561	1463	57.61	6
Heavy-Duty High-Capacity	610	24	0.43	0.56	646	1,424	122.7	27,582	91.2	20,512	1473	58.00	4
	762	30	0.58	0.76	723	1,593	122.7	27,582	91.2	20,512	1473	58.00	4
	914	36	0.74	0.97	808	1,782	122.7	27,582	91.2	20,512	1473	58.00	5
	1067	42	0.91	1.19	885	1,951	122.7	27,582	91.2	20,512	1473	58.00	5
	1219	48	1.06	1.39	577	1,271	122.7	27,582	91.2	20,512	1473	58.00	6
Ditching	1524	60	0.87	1.14	577	1,271	170.3	38,280	101.3	22,778	1057	41.62	0
General-Purpose High-Capacity	1219	48	1.09	1.43	577	1,271	122.7	27,582	91.2	20,512	1473	57.99	6

# 230G W



<b>Engine</b>		<b>230G W</b>	
Manufacturer and Model	Isuzu 4HK1		
Non-Road Emission Standard	EPA Interim Tier 4/EU Stage IIIB		
Cylinders	4		
Displacement	5.2 L (317 cu. in.)		
Net Peak Power (ISO 9249)	119 kW (159 hp) at 2,000 rpm		
Off-Level Capacity	60% (31 deg.)		
Aspiration	Turbocharged, air-to-air charge-air cooler		
<b>Cooling</b>			
High-efficiency, direct-drive suction-type fan			
<b>Powertrain</b>			
2-speed propel with creeper mode and automatic shift			
<b>Maximum Travel Speed</b>			
Creeper	2.9 km/h (1.8 mph)		
Low	7.4 km/h (4.6 mph)		
High	27.5 km/h (17.1 mph)		
<b>Front Axle</b>			
All-wheel drive; can be locked hydraulically in any position			
Oscillation	± 6 deg.		
<b>Brakes</b>			
Maintenance-free wet-disc brakes on front and rear axles; fully hydraulic service brakes			
<b>Tires</b>			
Standard size, dual-traction-type 11.00-20 16PR tires			
Drawbar Pull	11 115 kgf (24,504 lbf)		
<b>Hydraulics</b>			
<b>Main Pumps</b>			
2 variable-displacement axial-piston pumps			
Pump Flow, Maximum x 2	189 L/min. (49.9 gpm)		
<b>System Operating Pressure</b>			
Implement Circuits	34 300 kPa (4,975 psi)		
Travel Circuits	35 300 kPa (5,120 psi)		
Swing Circuits	30 200 kPa (4,380 psi)		
Power Boost	38 000 kPa (5,511 psi)		
<b>Controls</b>			
Pilot levers, short stroke, low-effort hydraulic pilot controls with shutoff lever			
<b>Cylinders</b>			
	<i>Bore</i>	<i>Rod Diameter</i>	<i>Stroke</i>
<b>Monoblock Boom (2)</b>	125 mm (4.9 in.)	85 mm (3.4 in.)	1241 mm (48.9 in.)
<b>2-Piece Boom (2)</b>	130 mm (5.1 in.)	85 mm (3.4 in.)	1024 mm (40.3 in.)
<b>Positioning, 2-Piece Boom (2)</b>	180 mm (7.1 in.)	110 mm (4.3 in.)	680 mm (26.8 in.)
<b>Arm (1)</b>	135 mm (5.3 in.)	95 mm (3.7 in.)	1475 mm (58.1 in.)
<b>Bucket (1)</b>	115 mm (4.5 in.)	80 mm (3.2 in.)	1060 mm (41.7 in.)
<b>Electrical</b>			
Voltage	24 volt		
Number of Batteries (12 volt)	2		
Alternator Rating	50 amp		
<b>Lights (6)</b>	Headlights (2), top of cab (2), rear of cab (1), and boom (1)		
<b>Driving Lights</b>	Headlights (2), turn signals and hazard lights, brake lights, and side marker lights		
<b>Swing Mechanism</b>			
Speed	11.2 rpm		
Torque	61 500 Nm (45,360 lb.-ft.)		
<b>Serviceability</b>			
<b>Refill Capacities</b>			
Fuel Tank	400 L (105.7 gal.)		
Engine Coolant	25 L (6.6 gal.)		
Engine Oil with Filter	23 L (6.1 gal.)		
Hydraulic Tank	130 L (34.3 gal.)		
Hydraulic System	270 L (71.3 gal.)		
Swing Drive	6.2 L (6.6 qt.)		
Transmission	2.5 L (2.6 qt.)		



**Serviceability** *(continued)* **230G W**

**Refill Capacities** *(continued)*

Differential Gear	
Front	11 L (2.9 gal.)
Rear	14.5 L (3.8 gal.)
Front and Rear Hubs	2.5 L x 2 (2.6 qt. x 2)

**Operating Weights**

With full fuel tank; 79-kg (175 lb.) operator; 0.8-m<sup>3</sup> (1.04 cu. yd.), 900-mm (35 in.), 660-kg (1,455 lb.) general-purpose bucket; 2.91-m (9 ft. 7 in.) arm; standard gauge; and 4500-kg (9,921 lb.) counterweight

	<i>Monoblock Boom</i>	<i>2-Piece Boom</i>
Front Outrigger and Rear Outrigger	23 600 kg (52,030 lb.)	24 140 kg (53,220 lb.)
Front Blade and Rear Outrigger	23 290 kg (51,350 lb.)	23 830 kg (52,540 lb.)

**Operating Dimensions**

	<i>Monoblock Boom</i>	<i>2-Piece Boom</i>
Arm Digging Force		
SAE	110 kN (24,729 lb.)	110 kN (24,729 lb.)
ISO	114 kN (25,628 lb.)	114 kN (25,628 lb.)
Bucket Digging Force		
SAE	141 kN (31,698 lb.)	141 kN (31,698 lb.)
ISO	158 kN (35,520 lb.)	158 kN (35,520 lb.)
<b>A</b> Maximum Reach	10.28 m (33 ft. 9 in.)	10.03 m (32 ft. 11 in.)
<b>B</b> Maximum Digging Depth	6.31 m (20 ft. 8 in.)	6.14 m (20 ft. 2 in.)
<b>C</b> Maximum Cutting Height	10.25 m (33 ft. 7 in.)	10.36 m (34 ft. 0 in.)
<b>D</b> Maximum Dumping Height	7.38 m (24 ft. 3 in.)	7.43 m (24 ft. 5 in.)
<b>E</b> Overall Height	3.19 m (10 ft. 6 in.)	3.32 m (10 ft. 11 in.)
<b>F</b> Overall Length		
Front Outrigger and Rear Outrigger	9.96 m (32 ft. 8 in.)	9.64 m (31 ft. 7 in.)
Front Blade and Rear Outrigger	9.96 m (32 ft. 8 in.)	9.64 m (31 ft. 7 in.)
<b>G</b> Minimum Swing Radius	3.55 m (11 ft. 8 in.)	3.42 m (11 ft. 3 in.)

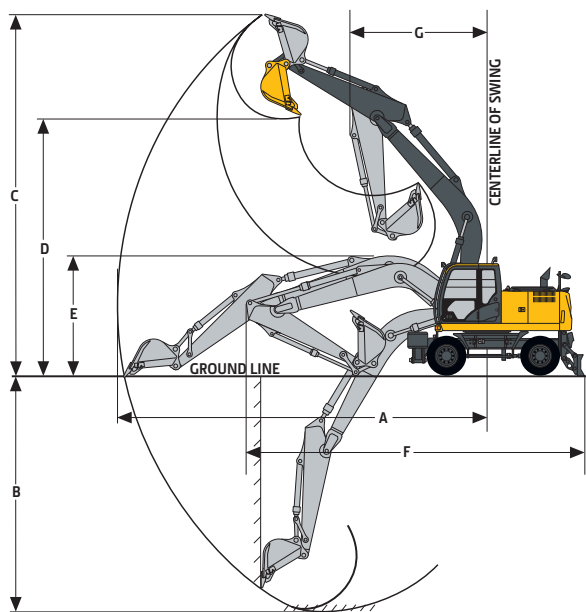

**230G W EXCAVATOR WITH MONOBLOCK BOOM**

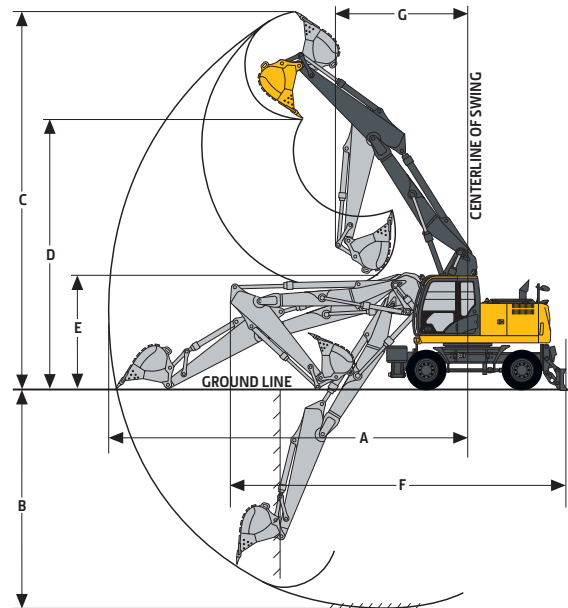

**230G W EXCAVATOR WITH 2-PIECE BOOM**

**Machine Dimensions**

**230G W**

With standard gauge and 2.91-m (9 ft. 7 in.) arm; dimensions are provided for both the front and rear outrigger configuration, and for the front blade and rear outrigger configuration

	<i>Monoblock Boom</i>	<i>2-Piece Boom</i>
<b>A</b> Overall Length	9.96 m (32 ft. 8 in.)	—
<b>A'</b> Overall Length	—	9.64 m (31 ft. 8 in.)
<b>B</b> Overall Height	3.19 m (10 ft. 6 in.)	—
<b>B'</b> Overall Height	—	3.32 m (10 ft. 11 in.)
<b>C</b> Rear-End Swing Radius	2.89 m (9 ft. 6 in.)	2.89 m (9 ft. 6 in.)
<b>D</b> Engine Cover Height	2.64 m (8 ft. 8 in.)	2.64 m (8 ft. 8 in.)
<b>E</b> Counterweight Clearance	1.25 m (4 ft. 1 in.)	1.25 m (4 ft. 1 in.)
<b>F</b> Overall Width of Upperstructure	2.73 m (8 ft. 11 in.)	2.73 m (8 ft. 11 in.)
<b>G</b> Overall Height of Cab	3.19 m (10 ft. 6 in.)	3.19 m (10 ft. 6 in.)
<b>H</b> Overall Width of Tires	2.75 m (9 ft. 0 in.)	2.75 m (9 ft. 0 in.)
<b>J</b> Minimum Ground Clearance	0.35 m (13.6 in.)	0.35 m (13.6 in.)
<b>K</b> Wheelbase	2.75 m (9 ft. 0 in.)	2.75 m (9 ft. 0 in.)
<b>L</b> Swing Center to Rear Axle	1.35 m (4 ft. 5 in.)	1.35 m (4 ft. 5 in.)
<b>M</b> Front Overhang		
Front Outrigger and Rear Outrigger	1.38 m (4 ft. 6 in.)	1.38 m (4 ft. 6 in.)
Front Blade and Rear Outrigger	1.34 m (4 ft. 5 in.)	1.34 m (4 ft. 5 in.)
<b>N</b> Rear Overhang	1.09 m (3 ft. 7 in.)	1.09 m (3 ft. 7 in.)
<b>O</b> Maximum Blader Lower	0.21 m (8.3 in.)	0.21 m (8.3 in.)
<b>P</b> Overall Height of Blade	0.60 m (23.6 in.)	0.60 m (23.6 in.)
<b>Q</b> Maximum Blade Raise	0.38 m (14.8 in.)	0.38 m (14.8 in.)
<b>R</b> Overall Width of Blade	2.73 m (8 ft. 11 in.)	2.73 m (8 ft. 11 in.)
<b>S</b> Overall Width with Outrigger Retracted	2.74 m (9 ft. 0 in.)	2.74 m (9 ft. 0 in.)
<b>T</b> Overall Width with Outrigger Extended	3.91 m (12 ft. 10 in.)	3.91 m (12 ft. 10 in.)
<b>V</b> Overall Height of Boom (traveling)	3.98 m (13 ft. 1 in.)	3.98 m (13 ft. 1 in.)
<b>W</b> Front Overhang (traveling)	3.49 m (11 ft. 5 in.)	3.49 m (11 ft. 5 in.)

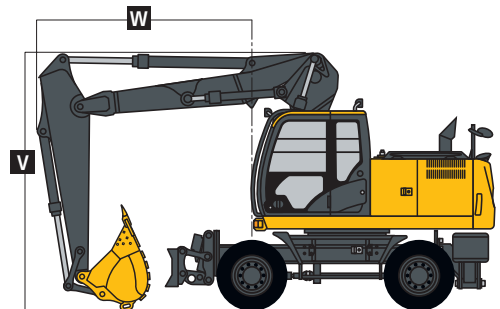
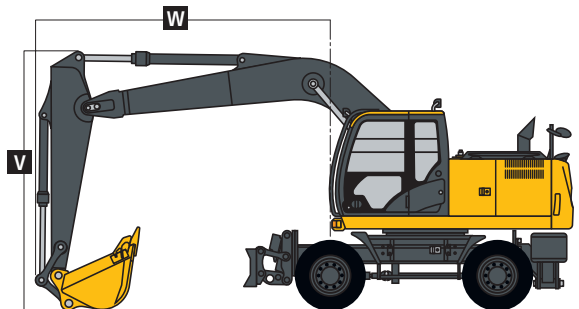
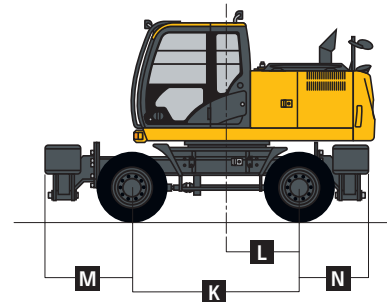
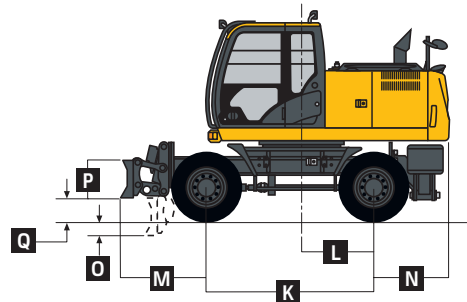
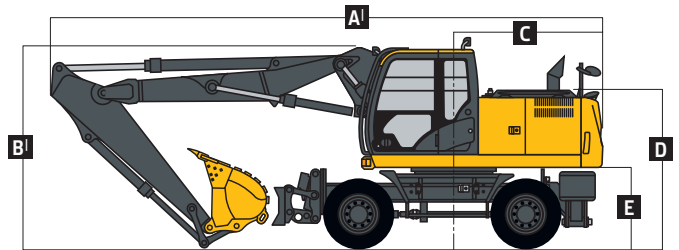
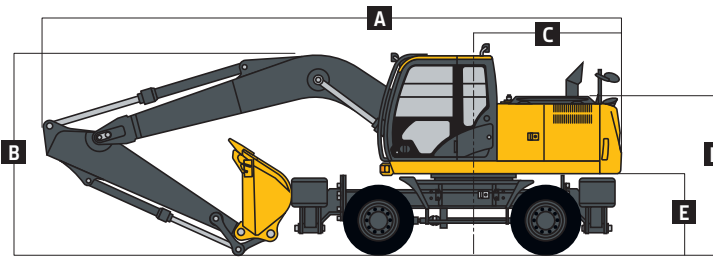
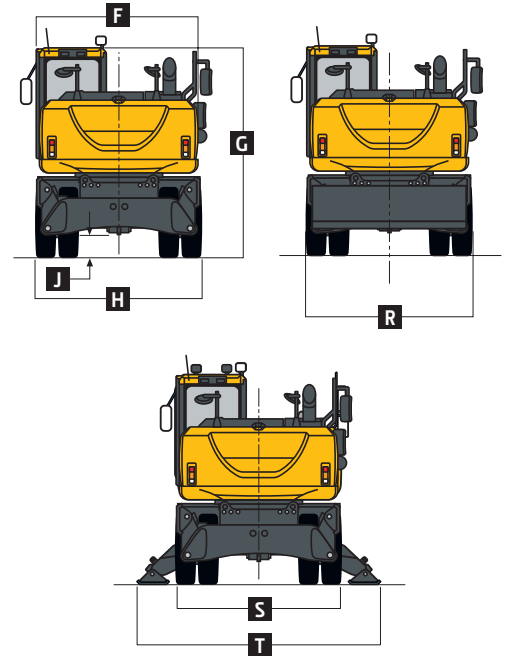

**Lift Capacities 230G W**

**Boldface type** indicates hydraulically limited capacities; **lightface type** indicates stability-limited capacities, in kg (lb.). Ratings at bucket lift hook; machine equipped with 666-kg (1,468 lb.) bucket, 2.91-m (9 ft. 7 in.) arm, and standard counterweight; and situated on firm, level, uniform supporting surface. Figures do not exceed 87% of hydraulic capacity or 75% of weight needed to tip machine.

Load Point Height	1.5 m (5 ft.)		3.0 m (10 ft.)		4.5 m (15 ft.)		6.0 m (20 ft.)		7.5 m (25 ft.)		
	Horizontal Distance from Centerline of Rotation		Over Front	Over Side	Over Front	Over Side	Over Front	Over Side	Over Front	Over Side	
<i>With monoblock boom, rear outriggers, and front blade down</i>											
6.0 m (20 ft.)								5250 (11,490)	5250 (11,490)	4460 (8,700)	4460 (8,700)
4.5 m (15 ft.)					7340 (15,750)	7340 (15,750)	6080 (13,190)	6080 (13,190)	5490 (11,990)	5490 (11,990)	4530 (9,720)
3.0 m (10 ft.)					10 010 (21,440)	10 010 (21,440)	7260 (15,690)	6310 (13,580)	6030 (13,100)	6030 (13,100)	4390 (9,450)
1.5 m (5 ft.)					12 130 (26,120)	9500 (20,440)	8360 (18,070)	6040 (13,000)	6580 (14,180)	6580 (14,180)	4260 (9,160)
Ground Line					12 910 (27,900)	9260 (19,890)	9020 (19,500)	5870 (12,620)	6490 (13,950)	6490 (13,950)	4160 (8,960)
-1.5 m (-5 ft.)			7790 (17,710)	7790 (17,710)	12 610 (27,290)	9220 (19,800)	9040 (19,540)	5810 (12,490)	6460 (13,890)	6460 (13,890)	4130 (8,900)
-3.0 m (-10 ft.)			13 470 (30,720)	13 470 (30,720)	11 360 (24,520)	9320 (20,020)	8230 (17,690)	5860 (12,610)			
-4.5 m (-15 ft.)					8620 (18,240)	8620 (18,240)					
<i>With monoblock boom and 4 outriggers down</i>											
6.0 m (20 ft.)								5250 (11,490)	5250 (11,490)	4460 (8,700)	4460 (8,700)
4.5 m (15 ft.)					7340 (15,750)	7340 (15,750)	6080 (13,190)	6080 (13,190)	5490 (11,990)	5490 (11,990)	5290 (11,370)
3.0 m (10 ft.)					10 010 (21,440)	10 010 (21,440)	7260 (15,690)	7260 (15,690)	6030 (13,100)	6030 (13,100)	5160 (11,090)
1.5 m (5 ft.)					12 130 (26,120)	11 440 (24,570)	8360 (18,070)	7140 (15,370)	6580 (14,270)	6580 (14,270)	5020 (10,800)
Ground Line					12 910 (27,900)	11 180 (23,980)	9020 (19,500)	6960 (14,980)	6730 (14,470)	6730 (14,470)	4920 (10,580)
-1.5 m (-5 ft.)			7790 (17,710)	7790 (17,710)	12 610 (27,290)	11 140 (23,890)	9040 (19,540)	6900 (14,840)	6700 (14,420)	6700 (14,420)	4890 (10,530)
-3.0 m (-10 ft.)			13 470 (30,720)	13 470 (30,720)	11 360 (24,520)	11 250 (24,120)	8230 (17,690)	6950 (14,960)			
-4.5 m (-15 ft.)					8620 (18,240)	8620 (18,240)					
<i>With 2-piece boom, rear outriggers, and front blade down</i>											
7.5 m (25 ft.)								4340 (7,850)	4340 (7,850)		
6.0 m (20 ft.)								5560 (12,100)	5560 (12,100)		
4.5 m (15 ft.)					6660 (14,390)	6660 (14,390)	6330 (13,770)	6330 (13,770)	5180 (10,650)	5180 (10,650)	4700 (10,060)
3.0 m (10 ft.)			11 090 (24,530)	11 090 (24,530)	9610 (20,660)	9610 (20,660)	7310 (15,840)	6690 (14,410)	6210 (13,540)	6210 (13,540)	4690 (10,020)
1.5 m (5 ft.)			13 990 (30,920)	13 990 (30,920)	11 700 (25,220)	10 290 (22,130)	8320 (18,010)	6630 (14,290)	6660 (14,460)	6660 (14,460)	4600 (9,840)
Ground Line	8310 (18,590)	8310 (18,590)	16 790 (36,730)	16 790 (36,730)	12 710 (27,490)	10 320 (22,180)	8980 (19,450)	6660 (14,340)	6820 (14,610)	6820 (14,610)	4470 (9,570)
-1.5 m (-5 ft.)	13 890 (31,150)	13 890 (31,150)	20 290 (44,280)	20 290 (44,280)	12 880 (27,880)	10 570 (22,690)	9160 (19,830)	6490 (13,910)	6690 (14,150)	6690 (14,150)	4340 (9,290)
-3.0 m (-10 ft.)	22 540 (51,050)	22 540 (51,050)	21 550 (46,640)	21 550 (46,640)	13 250 (28,770)	10 370 (22,180)	9010 (19,160)	6250 (13,400)			
-4.5 m (-15 ft.)	31 020 (69,820)	31 020 (69,820)	19 540 (41,120)	19 540 (41,120)							

**Lift Capacities (continued) 230G W**

**Boldface type** indicates hydraulically limited capacities; **lightface type** indicates stability-limited capacities, in kg (lb.). Ratings at bucket lift hook; machine equipped with 666-kg (1,468 lb.) bucket, 2.91-m (9 ft. 7 in.) arm, and standard counterweight; and situated on firm, level, uniform supporting surface. Figures do not exceed 87% of hydraulic capacity or 75% of weight needed to tip machine.

Load Point Height	1.5 m (5 ft.)		3.0 m (10 ft.)		4.5 m (15 ft.)		6.0 m (20 ft.)		7.5 m (25 ft.)	
	Over Front	Over Side	Over Front	Over Side	Over Front	Over Side	Over Front	Over Side	Over Front	Over Side
<i>With 2-piece boom and 4 outriggers down</i>										
7.5 m (25 ft.)							4340	4340		
							(7,850)	(7,850)		
6.0 m (20 ft.)							5560	5560		
							(12,100)	(12,100)		
4.5 m (15 ft.)					6660	6660	6330	6330	5180	5180
					(14,390)	(14,390)	(13,770)	(13,770)	(10,650)	(10,650)
3.0 m (10 ft.)			11 090	11 090	9610	9610	7310	7310	6210	5440
			(24,530)	(24,530)	(20,660)	(20,660)	(15,840)	(15,840)	(13,540)	(11,640)
1.5 m (5 ft.)			13 990	13 990	11 700	11 700	8320	7600	6660	5360
			(30,920)	(30,920)	(25,220)	(25,220)	(18,010)	(16,370)	(14,460)	(11,480)
Ground Line	8310	8310	16 790	16 790	12 710	11 930	8980	7640	6970	5240
	(18,590)	(18,590)	(36,730)	(36,730)	(27,490)	(25,640)	(19,450)	(16,460)	(15,050)	(11,210)
-1.5 m (-5 ft.)	13 890	13 890	20 290	20 290	12 880	12 130	9160	7610	6810	5100
	(31,150)	(31,150)	(44,280)	(44,280)	(27,880)	(26,080)	(19,830)	(16,300)	(14,150)	(10,930)
-3.0 m (-10 ft.)	22 540	22 540	21 550	21 550	13 250	12 370	9010	7370		
	(51,050)	(51,050)	(46,640)	(46,640)	(28,770)	(26,440)	(19,160)	(15,810)		
-4.5 m (-15 ft.)	31 020	31 020	19 540	19 540						
	(69,820)	(69,820)	(41,120)	(41,120)						

**Buckets**
**230G W**

A full line of buckets is offered to meet a wide variety of applications. Digging forces are with power boost. Buckets are equipped with John Deere TK-Series Bucket Teeth standard. Replaceable cutting edges and a variety of teeth are available through John Deere Parts. Optional side cutters add 150 mm (6 in.) to bucket widths. Capacities are SAE heaped ratings.

Type Bucket	Bucket Width		Bucket Capacity		Bucket Weight		Bucket Dig Force		Arm Dig Force, 2.91 m (9 ft. 7 in.)		Bucket Tip Radius		Number of Teeth
	mm	in.	m <sup>3</sup>	cu. yd.	kg	lb.	kN	lb.	kN	lb.	mm	in.	
General-Purpose High-Capacity	762	30	0.60	0.79	650	1,432	153.5	34,517	110.6	24,855	1473	58.00	4
	914	36	0.76	1.00	735	1,621	153.2	34,450	110.6	24,855	1473	58.00	5
	1067	42	0.93	1.22	812	1,790	153.2	34,450	110.6	24,855	1473	58.00	5
	1219	48	1.09	1.43	896	1,976	153.5	34,517	110.6	24,855	1473	58.00	6
Heavy-Duty	610	24	0.40	0.52	543	1,197	154.6	34,758	110.8	24,913	1463	57.61	4
	762	30	0.54	0.71	621	1,369	154.6	34,751	110.8	24,913	1463	57.61	4
	914	36	0.69	0.90	707	1,559	154.6	34,751	110.8	24,913	1463	57.61	5
	1067	42	0.83	1.09	785	1,731	154.6	34,751	110.8	24,913	1463	57.61	5
	1219	48	0.99	1.29	871	1,921	154.6	34,751	110.8	24,913	1463	57.61	6
Heavy-Duty High-Capacity	610	24	0.43	0.56	646	1,424	153.5	34,517	110.6	24,855	1473	58.00	4
	762	30	0.58	0.76	723	1,593	153.5	34,517	110.6	24,855	1473	58.00	4
	914	36	0.74	0.97	808	1,782	153.5	34,517	110.6	24,855	1473	58.00	5
	1067	42	0.91	1.19	885	1,951	153.5	34,517	110.6	24,855	1473	58.00	5
	1219	48	1.06	1.39	970	2,139	153.5	34,517	110.6	24,855	1473	58.00	6
Ditching	1524	60	0.87	1.14	577	1,271	214.0	48,102	122.2	27,463	1057	41.62	0
General-Purpose High-Capacity	1219	48	1.09	1.43	577	1,271	153.5	34,517	110.6	24,855	1473	57.99	6

# Additional equipment

Key: ● Standard ▲ Optional or special

See your John Deere dealer for further information.

## 190G 230G Engine

- ● Auto-idle system
- ● Automatic belt-tension device
- ● Batteries (2 – 12 volt)
- ● Coolant recovery tank
- ● Dual-element dry-type air filter
- ● Electronic engine control
- ● Enclosed fan guard (conforms to SAE J1308)
- ● Engine coolant to –37 deg. C (–34 deg. F)
- ● Fuel filter with water separator
- ● Full-flow oil filter
- ● Turbocharger with charge-air cooler
- ● 500-hour engine-oil-change interval
- ● Programmable auto-shutdown

## Hydraulic System

- ● Reduced-drift valve for boom down, arm in
- ● Auxiliary hydraulic valve section
- ● Spring-applied, hydraulically released automatic swing brake
- ● Brake valves for travel circuits
- ● Individual control of outriggers
- ▲ ▲ Auxiliary hydraulic lines
- ▲ ▲ Auxiliary pilot and electric controls
- ● Hydraulic filter restriction indicator
- ● Low-flow/medium-pressure-assist hydraulics

## Undercarriage

- ● Brakes, 4 wheel, maintenance free, wet disc
- ● Creeper speed range
- ● Front axle, oscillating, lockable
- ▲ ▲ Front blade and rear outriggers (2)
- ▲ ▲ Outriggers (4)
- ● Parking brake
- ● Dual traction-type tires, 10.00-20, 14PR with spacer
- ● Dual traction-type tires, 11.00-20, 16PR with spacer
- ● Toolbox on left chassis

## 190G 230G Upperstructure

- ● Right- and left-hand mirrors
- ● Vandal locks with ignition key: Cab door / Fuel cap / Service doors

## Front Attachments

- 5.5-m (18 ft. 0 in.) monoblock boom with 2.71-m (8 ft. 11 in.) arm
- 5.68-m (18 ft. 8 in.) monoblock boom with 2.91-m (9 ft. 7 in.) arm
- ▲ Variable-geometry, 2-piece boom with 2.71-m (8 ft. 11 in.) arm
- ▲ Variable-geometry, 2-piece boom with 2.91-m (9 ft. 7 in.) arm
- ● Centralized lubrication system
- ● Dirt seals on all bucket pins
- ▲ ▲ Buckets: Ditching / General purpose / General-purpose high capacity / Heavy duty / Heavy-duty high capacity / Side cutters and teeth

## Operator's Station

- ● Adjustable independent-control positions (levers-to-seat, seat-to-pedals)
- ● AM/FM radio
- ● Auto climate control/air conditioner with heater and pressurizer
- ● Built-in Operator's Manual storage compartment and manual
- ● Cell-phone power outlet, 12 volt
- ● Coat hook
- ● Deluxe suspension cloth seat with 100-mm (4 in.) adjustable armrests
- ● Floor mat
- ● Front windshield wiper with intermittent speeds
- ● Gauges (illuminated): Engine coolant / Fuel level / Speedometer
- ● Horn, electric
- ● Hour meter, electric
- ● Hydraulic shutoff lever, all controls
- ● Hydraulic warm-up control
- ● Interior light
- ● Large cup holder
- ● Machine Information Center (MIC)
- ● Mode selectors (illuminated): Power modes (3) / Work mode (1)
- ● High/low travel mode with creeper range

## 190G 230G Operator's Station (continued)

- ● Multifunction, color LCD monitor with: Diagnostic capability / Multiple-language capabilities / Maintenance tracking / Clock / System monitoring with alarm features: Auto-idle indicator, Auto-shutdown indicator, brake pressure audible alarm, engine air cleaner restriction indicator light, engine check, engine coolant temperature indicator light with audible alarm, engine oil pressure indicator light with audible alarm, low-alternator-charge indicator light, low-fuel indicator light, fault-code alert indicator, fuel-rate display, water-in-fuel light, wiper-mode indicator, work-lights-on indicator, and work-mode indicator
  - ● Motion alarm with cancel switch (conforms to SAE J994)
  - ● Power-boost switch on right control lever
  - ● SAE 2-lever control pattern
  - ● Seat belt, 51 mm (2 in.), retractable
  - ▲ ▲ Seat belt, 76 mm (3 in.), non-retractable
  - ● Tinted glass
  - ● Transparent tinted overhead hatch
  - ● Tilting steering column
  - ● Sun visor
  - ● Windshield washer/wiper with constant and intermittent speeds
  - ▲ ▲ Window vandal-protection covers
- ## Electrical
- ● 50-amp alternator
  - ● Blade-type multi-fused circuits
  - ● Positive-terminal battery covers
  - ● JDLink™ Ultimate wireless communication system (available in specific countries; see your dealer for details)
- ## Lights
- ● Headlights (2)
  - ● Work lights, top of cab (2), rear of cab (1), and boom (1)
  - ● Turn signals / Hazard lights
  - ● Brake lights
  - ● Side marker lights



Net engine power is with standard equipment including air cleaner, exhaust system, alternator, and cooling fan at test conditions specified per ISO 9249. No derating is required up to 3050-m (10,000 ft.) altitude. Specifications and design subject to change without notice. Wherever applicable, specifications are in accordance with SAE standards. Except where otherwise noted, these specifications are based on units with full fuel tanks and 79-kg (175 lb.) operators; a 190G W unit with 0.7-m<sup>3</sup> (0.92 cu. yd.), 900-mm (35 in.) bucket and 2.71-m (8 ft. 11 in.) arm; and a 230G W unit with 0.8-m<sup>3</sup> (1.04 cu. yd.), 900-mm (35 in.) bucket and 2.91-m (9 ft. 7 in.) arm.