



MODELS

75G	180G	300G
85G	210G	345G
130G	245G	350G
135G	250G	380G
160G	290G	470G



Dedicated Pin Grabber Coupler

Built for Safety. Optimized for Deere.

The all-new dedicated pin grabber coupler from Brandt delivers strong, safe coupling with your John Deere attachments while optimizing your performance. Its robust design utilizes fewer moving parts for superior reliability, all while meeting the rigorous ISO 13031, EN 474, and AS 4772 safety standards.

① Safety

This coupler delivers a strong connection that you can count on, no matter what:

- Rear wedge keeps the rear pin secured without relying on gravity, preventing a swinging attachment in the event of a hydraulic failure.
- Hydraulic check valve maintains pressure in the cylinders in the event of hydraulic hose breakage until proper function is restored.
- Internal safety-lock is spring-engaged and hydraulically released to keep the rear wedge in place, securing the pin.
- Hydraulic interlock requires the coupler to be fully curled towards the cab in order to be disengaged, preventing accidental attachment drops.

② Productivity

This coupler is faster and easier to operate, enabling you to accomplish more:

- Cycle times are faster than the competition, saving valuable time with each transition between attachments.
- Bevelled front-pin hooks provide a perfect fit with Deere OEM attachments, enabling perfect alignment for faster, easier connections.
- Deere-specific design ensures seamless compatibility with attachments while optimizing the digging capabilities of the excavator.

③ Reliability

The reliable design enables longer equipment life and allows you to tackle the toughest jobs with ease:

- Purpose-built coupler has a simple, Deere-optimized design that you can depend on for even the toughest tasks.
- Creates a fast, reliable connection that does not rely on gravity to engage/disengage and allows quicker, easier attachment changes.

DEDICATED PIN GRABBER COUPLER

FEATURES

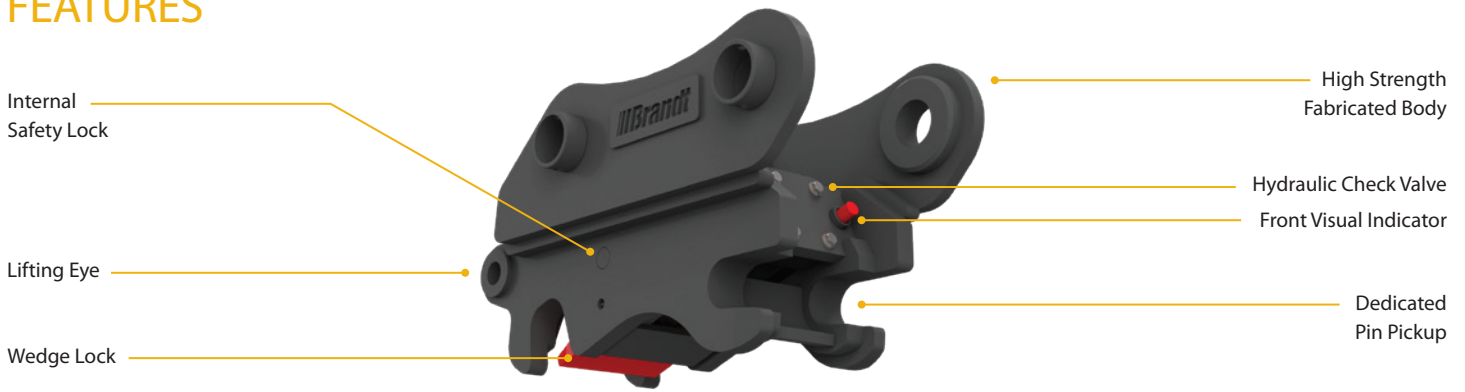

Audible Buzzer and Lights

Keeps the operator informed of when the coupler is unlocked.

High-Strength Steel Body

Utilizes a lightweight yet robust design to maximize the life of the coupler.

Brightly Coloured Wedge Lock

Give the operator clear visual confirmation of proper engagement from the cab.

Front Visual Indicator

Provides a clear visual if the wedge is fully retracted, indicating no rear pin engagement.

SPECIFICATIONS

SERIES	80	120	150	200	250	300	400
PART #	1101273	1101274	1101275	1101822	1101277	1101823	1101279
MACHINE	75G / 85G	130G / 135G	160G	180G, 210G, 245G	250G, 290G, 300G, 345G	350G / 380G	470G
Weight	17,952 lb	29,009 - 30,620 lb	39,526 lb	45,170 - 56,170 lb	56,100 - 78,710 lb	79,655 lb	112,916 lb
Coupler Weight	81.6 kg	149.7 kg	222.3 kg	276.7 kg	304.8 kg	412.8 kg	539.8 kg
	180 lb	330 lb	490 lb	610 lb	680 lb	910 lb	1190 lb
Minimum Width	195 mm	249 mm	302 mm	302 mm	403 mm	414 mm	465 mm
	7.68"	9.81"	11.87"	11.87"	15.87"	16.31"	18.31"
Pin Spread	305 - 316 mm	356 - 368 mm	386 - 405 mm	466 - 486 mm	470 - 490 mm	575 - 595 mm	565 - 595 mm
	12.01 - 12.44"	14.01 - 14.48"	15.20 - 15.94"	18.35 - 19.13"	18.50 - 19.29"	22.64 - 23.43"	22.24 - 23.23"
Front Pin Dia.	50 mm	65 mm	80 mm	80 mm	90 mm	100 mm	110 mm
Rear Pin Dia.	50 mm	65 mm	80 mm	80 mm	90 mm	100 mm	110 mm
Front Boss Width	202 mm	256 mm	307 mm	307 mm	410 mm	420 mm	472 mm
Rear Boss Width	202 mm	256 mm	307 mm	307 mm	410 mm	420 mm	472 mm
Pin Center	310 mm	362 mm	401 mm	472 mm	474 mm	585 mm	572 mm

For more information:
 Call us at **1-844-3bucket (1-844-328-2538)**
 Email us at beslorderdesk@brandt.ca
 Or visit us at www.brandt.ca

Brandt Equipment Solutions
 PO Box 1876, 302 Mill Street
 Regina, SK, Canada
 S4P 3E1

