



DB130

DRILLS AND BULLDOZERS OTHER TRACKED EQUIPMENT UP TO 130 TONNES



The Sleipner transport solution can significantly increase the productivity of your mine.

HOW?

By moving mining drills and bulldozers quickly and safely, and saving more valuable time for productive work.

How is this possible?
READ ON.



DB130



INCREASE YOUR PRODUCTIVITY

The revolutionary Sleipner DB130 improves on-site mobility of your tracked equipment. Sleipner DB130 offers you fast loading, agile transporting and reliable braking. With DB130 you get more flexibility to your daily production planning. Drills and dozers can be picked-up and delivered right where they are working. Relocation of equipment becomes a routine part of more efficient, more reactive and therefore more productive daily planning.

COST SAVINGS

With Sleipner DB130 utilization, the drills' undercarriages last 2-3 times longer and the excessive undercarriage wear of bulldozers while traveling on tracks in 3rd gear is diminished. Moreover, the ease of relocation from the pit enables much more maintenance to be performed preventively and in the better conditions found in the workshop, resulting in large reductions in expensive and disruptive breakdowns.

EASE OF USE

- Quick rear-entry loading and unloading, loading time for dozers is less than two minutes
- Agile design will go anywhere in the pit
- One person can handle the whole loading procedure
- Flat, unencumbered loading platform with load-binding points
- Maximum towing speed 15 km/h with full load and 30 km/h without load
- Multipurpose, can accommodate all kinds of pit equipment besides drills and bulldozers: excavators, wheel loaders, trucks, bucket, pumps, light towers, etc.

SAFETY

- The advanced design of the DB offers incomparable safety and stability
- Trailer bed is wider than loaded equipment tracks
- There is no risk of overturning even if the wheels drop off the road.
- Railings and stairs ensure safe operator access to the load deck
- Advanced, proven braking system well integrated with the prime mover provides safe transport in every condition
- Reversing camera system ensures manoeuvring safety

HOW DOES IT WORK?

Hydraulically lowering bed enables fast loading. Drills or dozers can be driven on Sleipner DB130 in a matter of minutes. Once loaded, the bed is risen to horizontal position for transport using hydraulics powered by the towing ADT.

Uphill performance with full load when using Cat 745 or similar as a towing vehicle is 12 % in regular on-site conditions. Transporting downhill with full load is safe up to 14 %, thanks to the innovative brake system of the DB120PLUS. Drag brake surfaces of the trailer can be lowered to touch the road during downhill transportation and the ADT operator choose needed brake assist according to conditions. Secondary wheel brake system is connected to the ADT operating brake circuit.

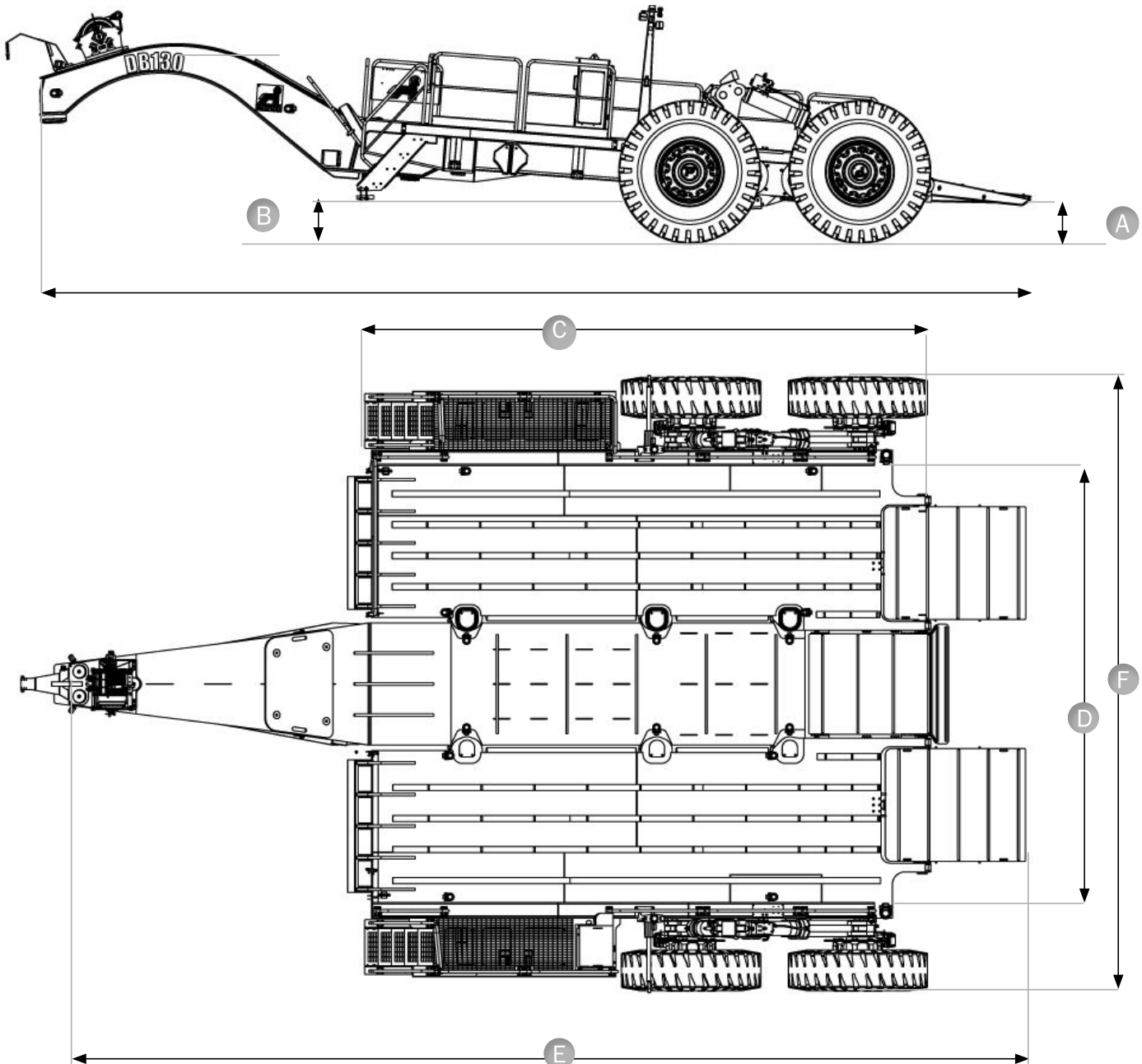

Dimensions

- A 400 mm
- B 580 mm
- C 8 720mm
- D 7 050mm
- E 15 090 mm
- F 9 910 mm

| | |
|---------------------|------------------------|
| Weight | 63 tonnes |
| Max allowed payload | 130 tonnes |
| Tyre size | 24.00-35.48 ply |
| Towing vehicle | Any 45 tonnes plus ADT |



SUITABLE FLEET

| | DB80 | DB130 |
|-------------------------|--|---|
| Max payload (tonnes) | 80 | 130 |
| Recommended prime mover | Bell B40, Cat 740, John Deere 410E, Volvo A40 | Bell B45/B50, Cat 745, John Deere 460E, Volvo A45/A60 |
| Turning radius | 13m | 14m |

| Suitable drills | DB80 | DB130 |
|---------------------------|------|-------|
| Atlas Copco Flexi ROC D65 | X | X |
| Atlas Copco DM30/35 | X | X |
| Atlas Copco DM45/DM50 | X | X |
| Atlas Copco DML-SP | X | X |
| Atlas Copco PV235 | X | X |
| Atlas Copco 271/275 | | X |
| Cat M6290 | X | X |
| Cat MD6240 | X | X |
| Cat MD6250 | X * | X |
| Cat MD6310 | | X |
| Sandvik DI650 / DP1500 | X | X |
| Sandvik D254S | X | X |
| Sandvik D45KS/D50KS | X | X |
| Sandvik D55SP | | X |
| Sandvik D75KS | | X |

* May require removal of handrails, depends on the configuration.

| Other equipment | DB80 | DB130 |
|-----------------|-------------------|--------------------|
| Dozers | Up to D10T / D375 | Up to D11T / D475A |
| Excavators | Up to 80 tonnes | Up to 130 tonnes |
| Mining trucks | Up to 777 / HD785 | Up to 777 / HD785 |
| Wheel dozers | Up to Cat 834K | Up to Cat 844K |
| Wheel loaders | Up to Cat 988K | Up to Cat 990K |

Notice: Some equipment may have some optional extras, like walkways or cable drums what can set limitations for physical suitability or operating weight. In order to ensure the equipment suitability to DB-series detailed fleet review is part of sales process.

Extra product options

Middle loading ramp for small equipment | Additional working lights I

Deck front handrails (foldable) | Winch | Right side stairs | Platform

Sleipner Finland Oy | sleipner@sleipner.com | www.sleipner.com