

450K/550K/650K CRAWLER DOZERS

60–78 kW (80–104 hp)



JOHN DEERE



We hear you loud and clear.

When customers sound off, we listen. So when participants of our Customer Advocate Group (CAG) asked us to turn down the noise and turn up productivity on our K-Series Dozers, we responded with an all-new 450K that's 16-percent more powerful than the previous model. Eco mode that regulates engine rpm and hydrostatic transmission to burn up to 20-percent less fuel in a wide range of applications. And Total Machine Control on the durable sealed-switch module for easy customization and reliable control of a variety of machine functions. There's more to like in the K-Series.

Specifications	450K	450K LGP
Rated Power	60 kW (80 net hp)	60 kW (80 net hp)
Base Weight	7959 kg (17,510 lb.)	8522 kg (18,752 lb.)
Specifications	550K	550K LGP
Rated Power	69 kW (92 net hp)	69 kW (92 net hp)
Base Weight	8981 kg (19,758 lb.)	9544 kg (21,000 lb.)
Specifications	650K XLT	650K LGP
Rated Power	78 kW (104 net hp)	78 kW (104 net hp)
Base Weight	9691 kg (21,320 lb.)	10 156 kg (22,343 lb.)



Pushes envelopes, too.

Power turns. Counter-rotating tracks. Power management. Infinitely variable travel speeds. John Deere has been introducing productivity-boosting advantages on our crawler dozers for more than 35 years. And our 650K, 550K, and redesigned, reimagined new 450K are loaded with even more performance enhancements, including Eco mode and Total Machine Control (TMC).

Our EPA Final Tier 4 (FT4)/EU Stage IV diesels meet emission regulations without sacrificing power or torque. The 450K delivers 16-percent more horsepower along with a more impressive power-to-weight ratio, available torque, and drawbar pull than its J-Series counterpart.

Simply set maximum desired ground speed and the power-management system automatically maintains peak engine rpm and power efficiency without stalling or shifting.

Counter-rotation boosts productivity by enabling an operator to overcome heavy corner loads and quickly reposition the blade on the go. Provides space-saving spot turns, too.

Infinitely variable range to 11 km/h (6.8 mph) allows total flexibility to match ground speed to the load. Travel can also be varied to fit specific applications, terrain conditions, or operating preferences — and even limited to maximize under-carriage life.

1. TMC enables an operator to customize control of decelerator mode and response, forward/reverse ground speed, steering modulation, and forward/reverse speed ratios, and even record machine usage.

2. Eco mode maximizes fuel economy by up to 20 percent without sacrificing performance, automatically adjusting engine rpm and transmission settings based on load.

3. When you order your dozer with electrohydraulic (EH) controls, it's grade-control ready. Our "open-architecture" design makes adding a grade-control system as easy as plugging in the components, calibrating, and going to work, whether your preference be Trimble, Leica, or a factory-installed Topcon 3D-MC² system.

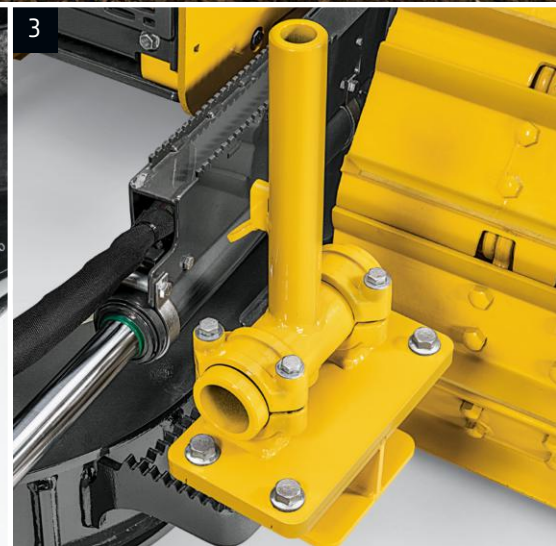

With you on the jobsite.

K-Series Dozers quietly go about the business of making your operators more comfortably productive. Inside their roomy, well-appointed cabs, you can almost hear fatigue drop. You'll discover everything your operators need to get more done in a 450K, 550K, or 650K.

Sealed-switch module (SSM) allows low-effort control of keyless start and enables exclusive features such as turbocharger cool-down, auto shutdown, and Eco mode. Touchpad security system requires a numeric pass code (when activated) to help prevent unauthorized machine operation.

Generous hydraulic flow and precise metering deliver powerful and quick blade response, while providing the natural "feel" that makes the most of an operator's grading ability.

At just 75 dBA, the cab is noticeably quiet. Spacious and comfortable, too.

1. Opt for the 360-deg. lighting package to extend your workday beyond daylight.
2. Cab-forward design allows a commanding view behind, below, and beyond the blade. Side and rear visibility is virtually unobstructed.
3. Optional electrohydraulic (EH) controls significantly improve blade response, including increased hydraulic motor capacity on the new 450K that enables 50-percent greater blade-raise performance. Blade Shake feature for Power-Angle-Tilt (PAT) blades automatically shakes off dirt at the touch of a button.

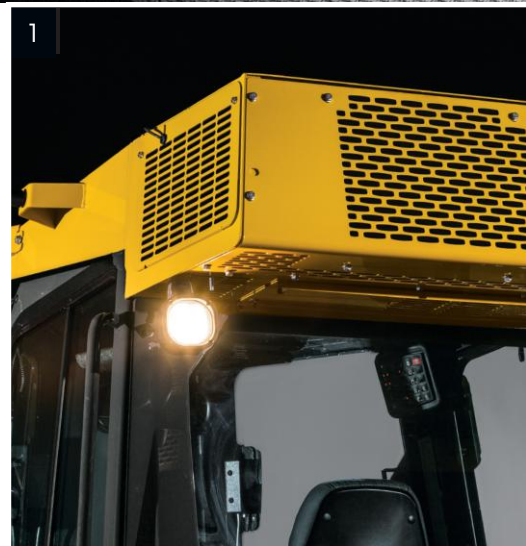

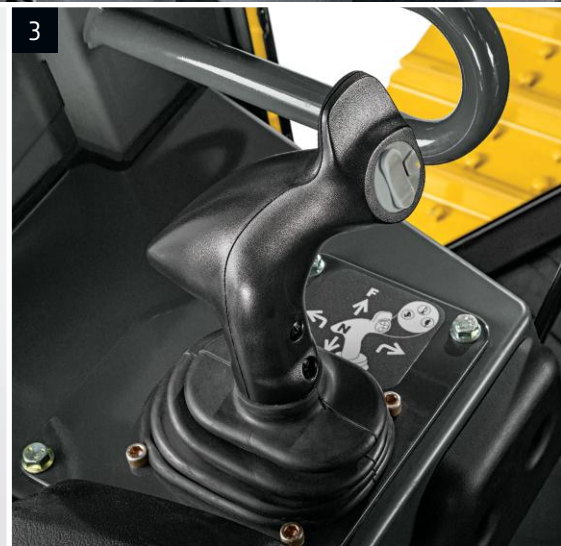





Nothing runs like a Deere, because nothing is built like it.

Designed and built with state-of-the-art tools and techniques by a quality-conscious workforce at our facility in Dubuque, Iowa, K-Series Dozers are loaded with uptime-boosting features. When you know how they're built, you'll run a Deere.

Eco mode automatically adjusts engine rpm and hydrostatic (HST) transmission settings based on load while maintaining ground speed, to help optimize fuel economy as much as 20 percent.

Transmission temperature is constantly monitored to protect the HST system. If temps get too hot or too cold, a warning light illuminates, and transmission and engine speed are automatically derated to prevent damage.

1. Heavy-duty sealed and lubricated undercarriage is built without compromise to keep these machines in the field. Available Maximum Life Undercarriage delivers up to twice the bushing life, for extra durability in extremely abrasive conditions. To further reduce maintenance and operating costs, contact your John Deere dealer about our undercarriage wear-assurance programs.

2. Direct-drive fan on the 450K and 550K provides efficient cooling, contains noise, and conserves precious fuel. Variable-speed fan on the 650K includes an optional reversing feature that runs only as needed.

3. Exclusive turbo cool-down increases durability by allowing the engine to idle momentarily prior to shutting down. Auto shutdown turns the engine off after an operator-determined period of machine inactivity, saving fuel and warranty hours.

Declare open season on operating costs.

We're pretty open-minded when it comes to keeping uptime up and daily operating costs down. With our K-Series Dozers, you'll spend less effort and expense getting ready for work — and more time getting work done.

1. Exhaust filter operation and status are indicated with icons and on-screen displays. Diagnostic monitor also provides easy-to-understand messages that help speed troubleshooting.
2. Available quick fluid-evacuation system helps speed servicing. 500-hour engine oil and 2,000-hour transmission and hydraulic fluid intervals decrease maintenance downtime and expense.
3. Auto-idle decreases engine speed when the dozer is not moving, to help maintain quiet working conditions and conserve precious fuel. Operators can program auto-idle to activate in increments from as soon as five sec. up to 15 min.

Serviceability improvements on the 550K and 650K include new composite fuel tank, redesigned diagnostic lines with pressure sensors, and John Deere transmission control unit software.

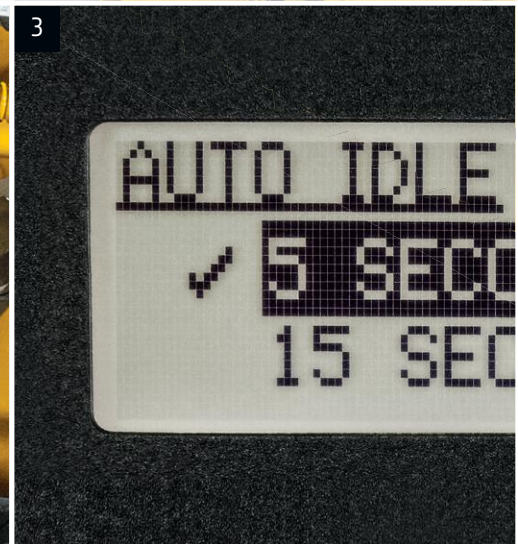



John Deere WorkSight™ is an exclusive suite of telematics solutions that increases uptime while lowering operating costs. At its heart, JDLINK™ Ultimate machine monitoring provides real-time utilization data and alerts to help you maximize productivity and efficiency while minimizing downtime. Remote diagnostics enable your dealer to read codes and record performance data without a trip to the jobsite.

John Deere Ultimate Uptime, featuring John Deere WorkSight, is a customizable support solution available exclusively from your Deere dealer. This flexible offering maximizes equipment availability with standard John Deere WorkSight capabilities that can help prevent future downtime and speed repairs when needed. In addition to the base John Deere WorkSight features, our dealers work with you to build an uptime package that meets the specific needs of your machine, fleet, project, and business, including customized maintenance and repair agreements, onsite parts availability, extended warranties, fluid sampling, response-time guarantees, and more.

Ash-service intervals for the diesel particulate filter (DPF) are condition based, meaning the machine will notify the operator before service is required. Typically, ash service is not necessary until the first engine overhaul. Machine application, regular maintenance practices, and type of lubricating oil impact ash-service intervals.

450K



Engine	450K / 450K LGP
Blade Type	<i>Power-Angle-Tilt (PAT)</i>
Manufacturer and Model	John Deere PowerTech™ PWS 4045
Non-Road Emission Standard	EPA Final Tier 4/EU Stage IV
Displacement	4.5L (276 cu. in.)
SAE Net Rated Power	60 kW (80 hp) at 2,200 rpm
Net Peak Torque	354 Nm (261 ft.-lb.) at 1,400 rpm
Aspiration	Turbocharged with charge-air cooler
Air Cleaner	Dual-stage dry tube with tangential unloader
Cooling	
Type	Blower-type, direct-drive cooling fan
Engine Coolant Rating	-37 deg. C. (-34 deg. F)
Engine Radiator	8.47 fins per in.
Powertrain	
Transmission	Automatic, dual-path, hydrostatic (HST) drive; load-sensing feature automatically adjusts speed and power to match changing load conditions; each individually controlled track is powered by a variable-displacement piston pump and variable-displacement motor combination; ground-speed selection buttons on single-lever steering and direction control; independently selectable reverse speed ratios of 100%, 115%, or 130% of forward ground speed; decelerator pedal controls ground speed to stop
System Relief Pressure	34 887 kPa (5,060 psi)
Travel Speeds	
Forward and Reverse	8.0 km/h (5.0 mph)
Maximum (optional)	9.7 km/h (6.0 mph)
Steering	Single-lever steering, direction control, and counter-rotation; full power turns and infinitely variable track speeds provide unlimited maneuverability and optimum control; HST steering eliminates steering clutches and brakes
Final Drives	Triple-reduction final drives mounted independently of track frames and dozer push frames for isolation from shock loads
Total Ratio	48.4 to 1
Drawbar Pull	
Maximum	122 kN (27,500 lb.)
At 1.9 km/h (1.2 mph)	80 kN (17,900 lb.)
At 3.2 km/h (2.0 mph)	48 kN (10,900 lb.)
Brakes	
Service	HST (dynamic) braking stops the machine when the direction/steering control lever is moved to neutral or the decelerator is depressed to the detent
Parking	Exclusive spring-applied, hydraulically released park-brake feature engages wet, multiple-disc brakes automatically whenever the engine stops, the operator depresses the decelerator pedal to the brake position, the unit is in neutral for 3 seconds (with detected motion), or the park-lock lever is in the park position; machine cannot be driven with brake applied, minimizing wearout or need for adjustment
Hydraulics	
Type	Open-center hydraulic system with fixed-displacement gear pump
Pump Displacement	36.4 cc
System Relief Pressure	20 684 kPa (3,000 psi)
Maximum Flow at Unloaded High Idle	80 L/m (21 gpm)
Control	3-function direct-acting T-bar joystick with push-button angle function

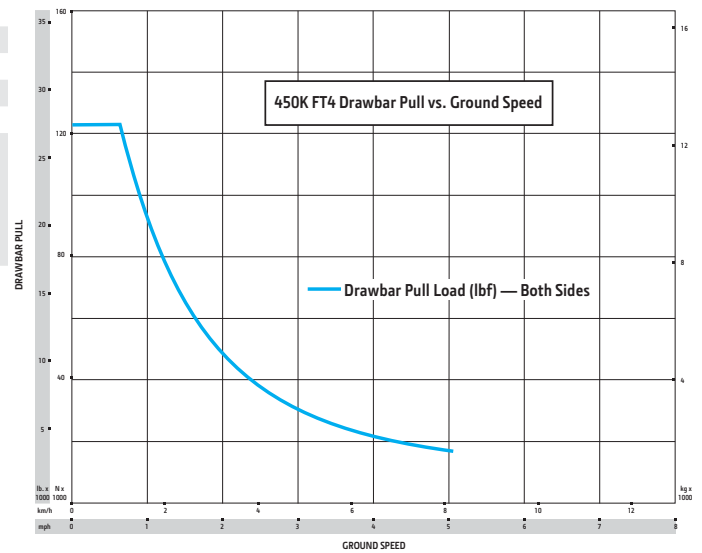



Electrical	450K / 450K LGP	
Blade Type	PAT	
Voltage	24 volts	
Capacity		
Battery	950 CCA	
Reserve	190 min.	
Alternator Rating		
Cab	100 amp	
Canopy	100 amp	
Lights	Grille mounted (2), rear mounted (2), and rear reflectors (2)	
Undercarriage	450K	450K LGP
Blade Type	PAT	PAT
Tracks	John Deere DuraTrax™ features large deep-heat-treated components; pins and bushings are sealed for life; rollers and idlers are permanently sealed and lubricated; full-length track-frame covers reduce material buildup and ease cleaning	
Track Gauge	1448 mm (57 in.)	1651 mm (65 in.)
Grouser Width	406 mm (16 in.)	610 mm (24 in.)
Chain	Sealed and lubricated	Sealed and lubricated
Shoes, Each Side	40 standard and Extended Life / 37 Maximum Life	40 standard and Extended Life / 37 Maximum Life
Track Rollers, Each Side	6	6
Track Length on Ground	2184 mm (86 in.)	2184 mm (86 in.)
Ground Contact Area	17 755 cm ² (2,752 sq. in.)	26 632 cm ² (4,128 sq. in.)
Ground Pressure	43.9 kPa (6.4 psi)	31.3 kPa (4.5 psi)
Track Pitch	160 mm (6.3 in.) standard / 171 mm (6.7 in.) Maximum Life	
Operator Station	450K / 450K LGP	
ROPS (ISO 3471 – 2008) and FOPS (ISO 3449 – 2005)		
Serviceability		
Refill Capacities		
Fuel Tank with Lockable Cap	202 L (53.45 gal.)	
Diesel Exhaust Fluid (DEF) Tank	11.8 L (3.1 gal.)	
Cooling System with Recovery Tank	21.1 L (5.6 gal.)	
Engine Oil with Filter	19 L (20 qt.)	
Hydraulic/HST Oil (common reservoir) with Filters	100 L (26.42 gal.)	
Final Drive (per tractor)	17 L (4.6 gal.)	
Operating Weights	450K	450K LGP
Blade Type	PAT	PAT
<i>Base Weight (with standard equipment, rollover protective structure [ROPS], full fuel tank, and 79-kg [175 lb.] operator)</i>	7959 kg (17,510 lb.)	8522 kg (18,752 lb.)
Optional Components		
Cab with Pressurizer and Heater/Air Conditioner	306 kg (675 lb.)	306 kg (675 lb.)
ROPS Canopy		
Heater	12 kg (26 lb.)	12 kg (26 lb.)
Front and Door Screens	81 kg (179 lb.)	81 kg (179 lb.)
Rear Screen	34 kg (76 lb.)	34 kg (76 lb.)
Side Screens	43 kg (94 lb.)	43 kg (94 lb.)
Limb Risers (ROPS canopy and cab)	95 kg (209 lb.)	95 kg (209 lb.)
Counterweight		
Front	109 kg (240 lb.)	109 kg (240 lb.)
Rear	150 kg (330 lb.)	150 kg (330 lb.)
Retrieval Hitch	23 kg (50 lb.)	23 kg (50 lb.)
Drawbar, Extended Rigid	33 kg (72 lb.)	33 kg (72 lb.)
Winch	652 kg (1,437 lb.)	652 kg (1,437 lb.)
Fairlead, 4 Roller	85 kg (187 lb.)	85 kg (187 lb.)
Full-Length Rock Guards	117 kg (257 lb.)	131 kg (288 lb.)
Maximum Life Undercarriage	88 kg (193 lb.)	132 kg (290 lb.)
Track Shoes		
406 mm (16 in.)	In base	—
610 mm (24 in.)	—	In base

Machine Dimensions	450K / 450K LGP
A Overall Height to Roof	2799 mm (9 ft. 2 in.)
B Tread Depth with Single-Bar Grouser	49 mm (1.9 in.)
C Ground Clearance in Dirt	329 mm (13 in.)
D Overall Length	4016 mm (158 in.) (13 ft. 2 in.)
E Blade Lift Height	772 mm (30.4 in.)
F Blade Digging Depth	528 mm (20.8 in.)
G Blade Cutting-Edge Angle, Adjustable	52 to 60 deg.

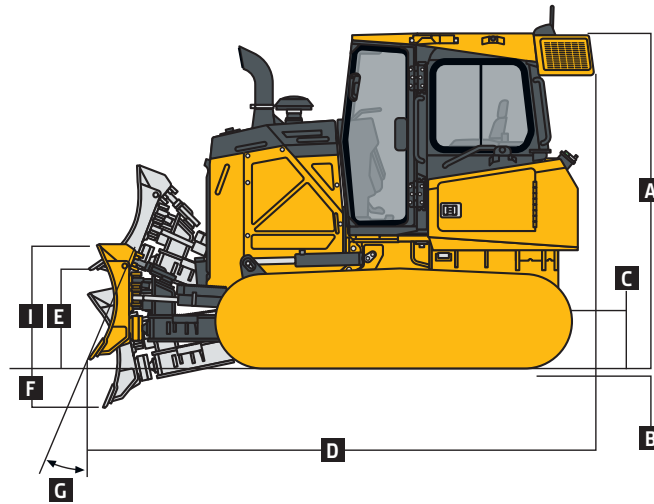

450K / 450K LGP WITH POWER-ANGLE-TILT (PAT) BLADE

Machine Dimensions (continued)	450K	450K LGP
Blade Type	PAT	PAT
Straight		
H Blade Width	2464 mm (97 in.) (8 ft. 1 in.)	2921 mm (115 in.) (9 ft. 7 in.)
I Blade Height	955 mm (3 ft. 2 in.)	955 mm (3 ft. 2 in.)
SAE Capacity	1.6 m ³ (2.1 cu. yd.)	2.0 m ³ (2.6 cu. yd.)
Weight	494 kg (1,090 lb.)	628 kg (1,385 lb.)
C-Frame Assembly Weight (without blade)	330 kg (727 lb.)	330 kg (727 lb.)
J Blade Angle	25.4 deg.	25.4 deg.
K Overall Width with Blade Angled	2225 mm (7 ft. 4 in.)	2639 mm (8 ft. 8 in.)
L Blade Tilt (uses tilt jack)	338 mm (13.3 in.)	399 mm (15.7 in.)
M Cut Reach	56 mm (2.2 in.)	58.4 mm (2.2 in.)
N Width Over Track	1854 mm (6 ft. 1 in.)	2261 mm (7 ft. 5 in.)
O Cast Reach	318 mm (12.5 in.)	320 mm (12.6 in.)
Straight (option)		
H Blade Width	2921 mm (115 in.) (9 ft. 7 in.)	3150 mm (124 in.) (10 ft. 4 in.)
I Blade Height	955 mm (3 ft. 2 in.)	894 mm (35 in.)
SAE Capacity	2.0 m ³ (2.6 cu. yd.)	1.9 m ³ (2.5 cu. yd.)
Weight	628 kg (1,385 lb.)	631 kg (1,391 lb.)
C-Frame Assembly Weight (without blade)	330 kg (727 lb.)	330 kg (727 lb.)
J Blade Angle	25.4 deg.	25.4 deg.
K Overall Width with Blade Angled	2639 mm (8 ft. 8 in.)	2845 mm (9 ft. 4 in.)
L Blade Tilt (uses tilt jack)	399 mm (15.7 in.)	429 mm (16.9 in.)
M Cut Reach	262 mm (10.3 in.)	163 mm (6.4 in.)
N Width Over Track	1854 mm (6 ft. 1 in.)	2261 mm (7 ft. 5 in.)
O Cast Reach	523 mm (20.6 in.)	424 mm (17.0 in.)

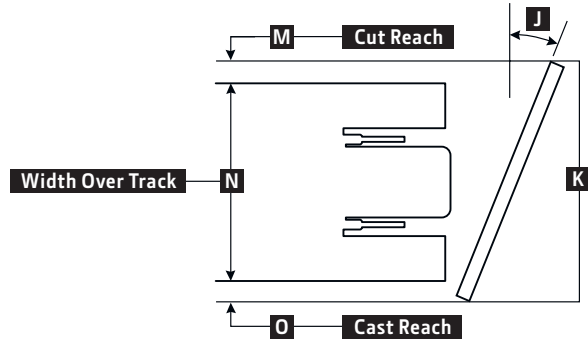
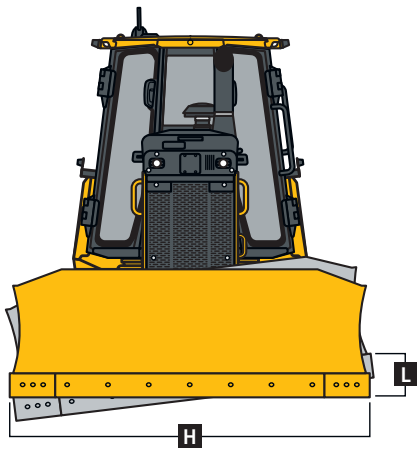
**Rear Ripper** 450K / 450K LGP**Blade Type** PAT

Multi-shank parallelogram ripper with 5 pockets and 3 shanks

Weight 981 kg (2,163 lb.)

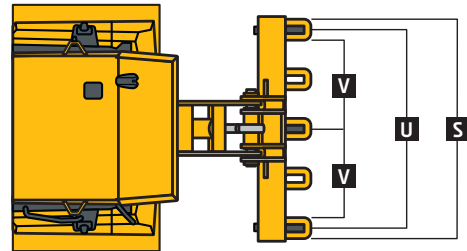
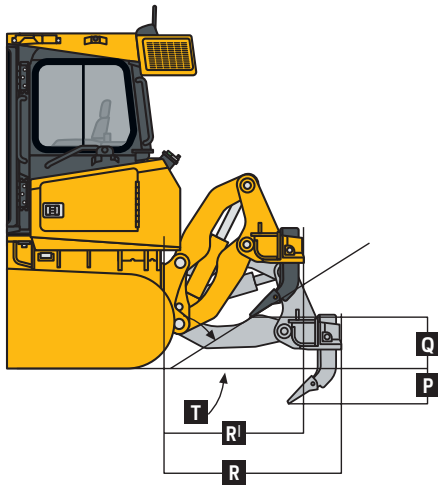
P Maximum Penetration 508 mm (20 in.)**Q** Maximum Clearance Under Tip 508 mm (20 in.)**R** Overall Length, Lowered Position 1450 mm (57 in.) (4 ft. 9 in.)**R^l** Overall Length, Raised Position 1015 mm (40 in.) (3 ft. 4 in.)**S** Overall Beam Width 1830 mm (6 ft. 0 in.)**T** Slope Angle (full raise) 40 deg.**U** Ripping Width 1670 mm (5 ft. 6 in.)**V** Distance Between Shanks 806 mm (32 in.)

550K

Engine	550K / 550K LGP
Blade Type	<i>Power-Angle-Tilt (PAT)</i>
Manufacturer and Model	John Deere PowerTech™ PWS 4045
Non-Road Emission Standard	EPA Final Tier 4/EU Stage IV
Displacement	4.5L (276 cu. in.)
SAE Net Rated Power	69 kW (92 hp) at 2,200 rpm
Net Peak Torque	420 Nm (310 ft.-lb.) at 1,400 rpm
Aspiration	Turbocharged with charge-air cooler
Air Cleaner	Dual-stage dry tube with tangential unloader
Cooling	
Type	Blower-type, direct-drive cooling fan
Engine Coolant Rating	-37 deg. C. (-34 deg. F)
Engine Radiator	8.47 fins per in.
Powertrain	
Transmission	Automatic, dual-path, hydrostatic (HST) drive; load-sensing feature automatically adjusts speed and power to match changing load conditions; each individually controlled track is powered by a variable-displacement piston pump and variable-displacement motor combination; ground-speed selection buttons on single-lever steering and direction control; independently selectable reverse speed ratios of 100%, 115%, or 130% of forward ground speed; decelerator pedal controls ground speed to stop
System Relief Pressure	38 741 kPa (5,619 psi)
Travel Speeds	
Forward and Reverse	8.0 km/h (5.0 mph)
Maximum (optional)	9.7 km/h (6.0 mph)
Steering	Single-lever steering, direction control, and counter-rotation; full power turns and infinitely variable track speeds provide unlimited maneuverability and optimum control; HST steering eliminates steering clutches and brakes
Final Drives	Triple-reduction final drives mounted independently of track frames and dozer push frames for isolation from shock loads
Total Ratio	48.4 to 1
Drawbar Pull	
Maximum	134 kN (30,000 lb.)
At 1.9 km/h (1.2 mph)	94 kN (21,100 lb.)
At 3.2 km/h (2.0 mph)	58 kN (13,100 lb.)
Brakes	
Service	HST (dynamic) braking stops the machine when the direction/steering control lever is moved to neutral or the decelerator is depressed to the detent
Parking	Exclusive spring-applied, hydraulically released park-brake feature engages wet, multiple-disc brakes automatically whenever the engine stops, the operator depresses the decelerator pedal to the brake position, the unit is in neutral for 3 seconds (with detected motion), or the park-lock lever is in the park position; machine cannot be driven with brake applied, minimizing wearout or need for adjustment
Hydraulics	
Type	Open-center hydraulic system with fixed-displacement gear pump
Pump Displacement	36.4 cc
System Relief Pressure	20 684 kPa (3,000 psi)
Maximum Flow at Unloaded High Idle	80 L/m (21 gpm)
Control	3-function direct-acting T-bar joystick with push-button angle function

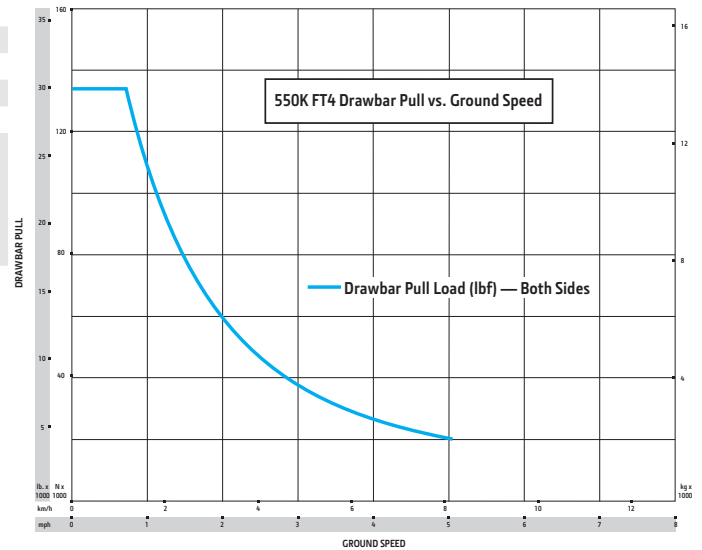



Electrical	550K / 550K LGP	
Blade Type	PAT	
Voltage	24 volts	
Capacity		
Battery	950 CCA	
Reserve	190 min.	
Alternator Rating		
Cab	100 amp	
Canopy	100 amp	
Lights	Grille mounted (2), rear mounted (2), and rear reflectors (2)	
Undercarriage	550K	550K LGP
Blade Type	PAT	PAT
Tracks	John Deere DuraTrax™ features large deep-heat-treated components; pins and bushings are sealed for life; rollers and idlers are permanently sealed and lubricated; full-length track-frame covers reduce material buildup and ease cleaning	
Track Gauge	1549 mm (61 in.)	1753 mm (69 in.)
Grouser Width	457 mm (18 in.)	610 mm (24 in.)
Chain	Sealed and lubricated	Sealed and lubricated
Shoes, Each Side	40 standard and Extended Life / 37 Maximum Life	40 standard and Extended Life / 37 Maximum Life
Track Rollers, Each Side	6	6
Track Length on Ground	2184 mm (86 in.)	2184 mm (86 in.)
Ground Contact Area	19 974 cm ² (3,096 sq. in.)	26 632 cm ² (4,128 sq. in.)
Ground Pressure	44.1 kPa (6.4 psi)	35.2 kPa (5.1 psi)
Track Pitch	160 mm (6.3 in.) standard and Extended Life / 171 mm (6.7 in.) Maximum Life	
Operator Station	550K / 550K LGP	
ROPS (ISO 3471 – 2008) and FOPS (ISO 3449 – 2005)		
Serviceability		
Refill Capacities		
Fuel Tank with Lockable Cap	202 L (53.45 gal.)	
Diesel Exhaust Fluid (DEF) Tank	11.8 L (3.1 gal.)	
Cooling System with Recovery Tank	21.1 L (5.6 gal.)	
Engine Oil with Filter	19 L (20 qt.)	
Hydraulic/HST Oil (common reservoir) with Filters	100 L (26.42 gal.)	
Final Drive (per tractor)	17 L (4.6 gal.)	
Operating Weights	550K	550K LGP
Blade Type	PAT	PAT
<i>Base Weight (with standard equipment, rollover protective structure [ROPS], full fuel tank, and 79-kg [175 lb.] operator)</i>	8981 kg (19,758 lb.)	9544 kg (21,000 lb.)
Optional Components		
Cab with Pressurizer and Heater/Air Conditioner	306 kg (675 lb.)	306 kg (675 lb.)
ROPS Canopy		
Heater	39 kg (85 lb.)	39 kg (85 lb.)
Front and Door Screens	81 kg (179 lb.)	81 kg (179 lb.)
Rear Screen	34 kg (76 lb.)	34 kg (76 lb.)
Side Screens	43 kg (94 lb.)	43 kg (94 lb.)
Limb Risers (ROPS canopy and cab)	95 kg (209 lb.)	95 kg (209 lb.)
Counterweight		
Front	109 kg (240 lb.)	109 kg (240 lb.)
Rear	150 kg (330 lb.)	150 kg (330 lb.)
Retrieval Hitch	23 kg (50 lb.)	23 kg (50 lb.)
Drawbar, Extended Rigid	33 kg (72 lb.)	33 kg (72 lb.)
Winch	652 kg (1,437 lb.)	652 kg (1,437 lb.)
Fairlead, 4 Roller	85 kg (187 lb.)	85 kg (187 lb.)
Full-Length Rock Guards	128 kg (282 lb.)	128 kg (282 lb.)
Maximum Life Undercarriage	258 kg (569 lb.)	258 kg (569 lb.)
Track Shoes		
457 mm (18 in.)	In base	—
610 mm (24 in.)	—	In base

Machine Dimensions	550K / 550K LGP
A Overall Height to Roof	2799 mm (9 ft. 2 in.)
B Tread Depth with Single-Bar Grouser	49 mm (1.9 in.)
C Ground Clearance in Dirt	329 mm (13 in.)
D Overall Length	4016 mm (158 in.) (13 ft. 2 in.)
E Blade Lift Height	772 mm (30.4 in.)
F Blade Digging Depth	523 mm (20.6 in.)
G Blade Cutting-Edge Angle, Adjustable	52 to 60 deg.

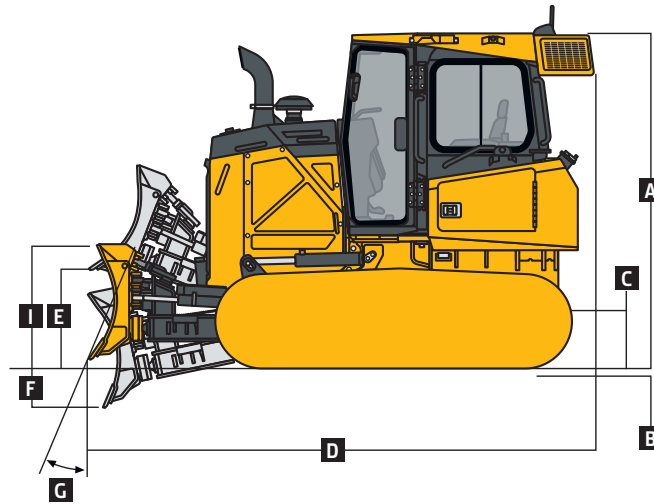

550K / 550K LGP WITH POWER-ANGLE-TILT (PAT) BLADE

Machine Dimensions (continued)	550K	550K LGP
Blade Type	PAT	PAT
Straight		
H Blade Width	2667 mm (105 in.) (8 ft. 9 in.)	2921 mm (115 in.) (9 ft. 7 in.)
I Blade Height	955 mm (3 ft. 2 in.)	955 mm (3 ft. 2 in.)
SAE Capacity	1.8 m ³ (2.4 cu. yd.)	2.0 m ³ (2.6 cu. yd.)
Weight	603 kg (1,330 lb.)	628 kg (1,385 lb.)
C-Frame Assembly Weight (without blade)	399 kg (879 lb.)	399 kg (879 lb.)
J Blade Angle	22.2 deg.	22.2 deg.
K Overall Width with Blade Angled	2469 mm (8 ft. 1 in.)	2705 mm (8 ft. 11 in.)
L Blade Tilt (uses tilt jack)	363 mm (14.3 in.)	399 mm (15.7 in.)
M Cut Reach	117 mm (4.6 in.)	56 mm (2.2 in.)
N Width Over Track	2007 mm (6 ft. 7 in.)	2362 mm (7 ft. 9 in.)
O Cast Reach	345 mm (18.3 in.)	287 mm (11.0 in.)
Straight (option)		
H Blade Width	2921 mm (115 in.) (9 ft. 7 in.)	3150 mm (124 in.) (10 ft. 4 in.)
I Blade Height	955 mm (3 ft. 2 in.)	894 mm (35 in.)
SAE Capacity	2.0 m ³ (2.6 cu. yd.)	1.9 m ³ (2.5 cu. yd.)
Weight	628 kg (1,385 lb.)	631 kg (1,391 lb.)
C-Frame Assembly Weight (without blade)	399 kg (879 lb.)	399 kg (879 lb.)
J Blade Angle	22.2 deg.	22.2 deg.
K Overall Width with Blade Angled	2705 mm (8 ft. 11 in.)	2916 mm (9 ft. 7 in.)
L Blade Tilt (uses tilt jack)	399 mm (15.7 in.)	429 mm (16.9 in.)
M Cut Reach	234 mm (9.2 in.)	163 mm (6.4 in.)
N Width Over Track	2007 mm (6 ft. 7 in.)	2464 mm (8 ft. 1 in.)
O Cast Reach	465 mm (18.3 in.)	391 mm (15.4 in.)

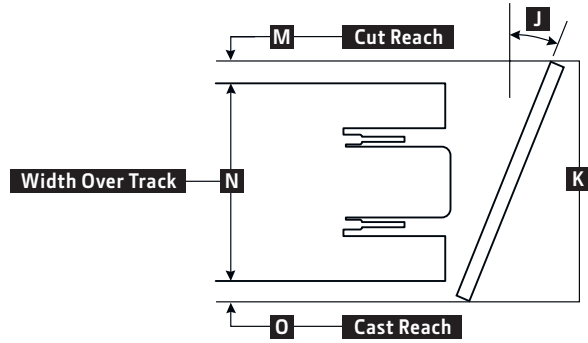
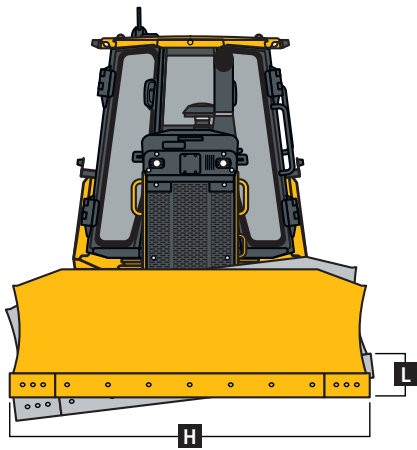
**Rear Ripper** 550K / 550K LGP**Blade Type** PAT

Multi-shank parallelogram ripper with 5 pockets and 3 shanks

Weight 981 kg (2,163 lb.)

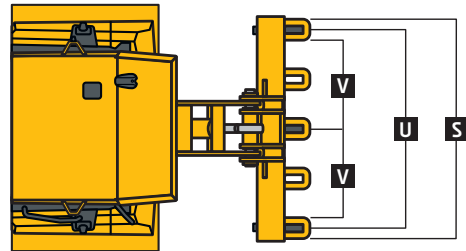
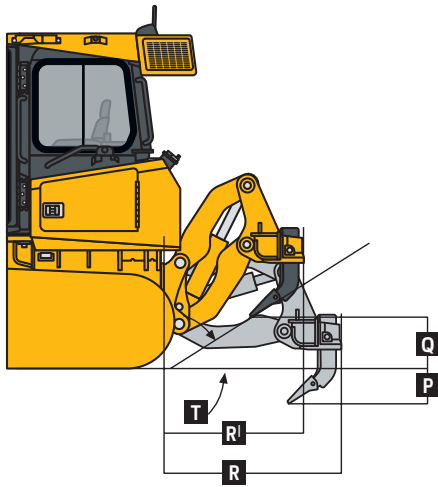
P Maximum Penetration 508 mm (20 in.)**Q** Maximum Clearance Under Tip 508 mm (20 in.)**R** Overall Length, Lowered Position 1450 mm (57 in.) (4 ft. 9 in.)**R^l** Overall Length, Raised Position 1015 mm (40 in.) (3 ft. 4 in.)**S** Overall Beam Width 1830 mm (6 ft. 0 in.)**T** Slope Angle (full raise) 40 deg.**U** Ripping Width 1670 mm (5 ft. 6 in.)**V** Distance Between Shanks 806 mm (32 in.)

650K

Engine	650K XLT / 650K LGP
Blade Type	<i>Power-Angle-Tilt (PAT)</i>
Manufacturer and Model	John Deere PowerTech™ PWS 4045
Non-Road Emission Standard	EPA Final Tier 4/EU Stage IV
Displacement	4.5L (276 cu. in.)
SAE Net Rated Power	78 kW (104 hp) at 2,200 rpm
Net Peak Torque	475 Nm (350 ft.-lb.) at 1,400 rpm
Aspiration	Turbocharged with charge-air cooler
Air Cleaner	Dual-stage dry tube with tangential unloader

Cooling	
Type	Variable-speed suction fan with optional reversing feature
Engine Coolant Rating	-37 deg. C. (-34 deg. F)
Engine Radiator	10 fins per in.

Powertrain	
Transmission	Automatic, dual-path, hydrostatic (HST) drive; load-sensing feature automatically adjusts speed and power to match changing load conditions; each individually controlled track is powered by a variable-displacement piston pump and variable-displacement motor combination; ground-speed selection buttons on single-lever steering and direction control; independently selectable reverse speed ratios of 100% ,115%, or 130% of forward ground speed; decelerator pedal controls ground speed to stop
System Relief Pressure	42 692 kPa (6,192 psi)

Travel Speeds	
Forward and Reverse	8.0 km/h (5.0 mph)
Maximum (optional)	9.7 km/h (6.0 mph)

Steering	Single-lever steering, direction control, and counter-rotation; full power turns and infinitely variable track speeds provide unlimited maneuverability and optimum control; HST steering eliminates steering clutches and brakes
-----------------	---

Final Drives	Triple-reduction final drives mounted independently of track frames and dozer push frames for isolation from shock loads
---------------------	--

Drawbar Pull	
Maximum	148 kN (33,600 lb.)
At 1.9 km/h (1.2 mph)	108 kN (24,200 lb.)
At 3.2 km/h (2.0 mph)	69 kN (15,600 lb.)

Brakes	
Service	HST (dynamic) braking stops the machine when the direction/steering control lever is moved to neutral or the decelerator is depressed to the detent

Parking	Exclusive spring-applied, hydraulically released park-brake feature engages wet, multiple-disc brakes automatically whenever the engine stops, the operator depresses the decelerator pedal to the brake position, the unit is in neutral for 3 seconds (with detected motion), or the park-lock lever is in the park position; machine cannot be driven with brake applied, minimizing wearout or need for adjustment
---------	--

Hydraulics	
Type	Open-center hydraulic system with fixed-displacement gear pump
Pump Displacement	36.4 cc
System Relief Pressure	20 684 kPa (3,000 psi)
Maximum Flow at Unloaded High Idle	80 L/m (21 gpm)
Control	3-function direct-acting T-bar joystick with push-button angle function

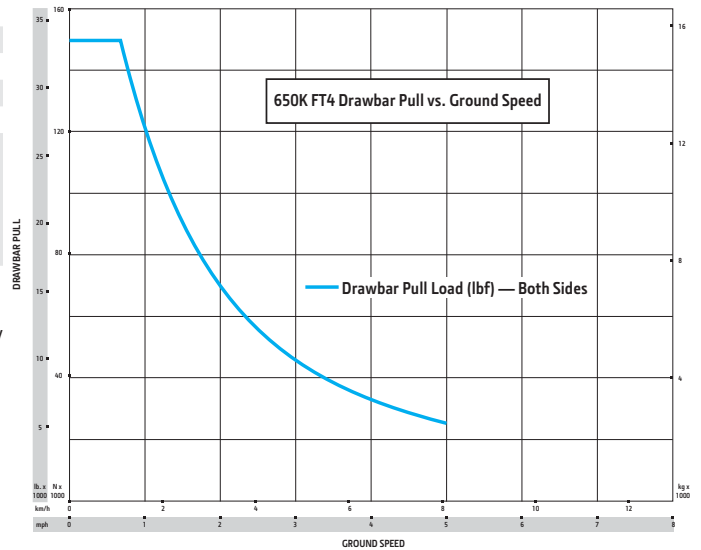



Electrical		650K XLT / 650K LGP	
Blade Type	PAT		
Voltage	24 volts		
Capacity			
Battery	950 CCA		
Reserve	190 min.		
Alternator Rating			
Cab	100 amp		
Canopy	100 amp		
Lights	Grille mounted (2), rear mounted (2), and rear reflectors (2)		
Undercarriage		650K XLT	650K LGP
Blade Type	PAT		PAT
Tracks	John Deere DuraTrax™ features large deep-heat-treated components; pins and bushings are sealed for life; rollers and idlers are permanently sealed and lubricated; full-length track-frame covers reduce material buildup and ease cleaning		
Track Gauge	1550 mm (61 in.)	1750 mm (69 in.)	
Grouser Width	457 mm (18 in.)	710 mm (28 in.)	
Chain	Sealed and lubricated		Sealed and lubricated
Shoes, Each Side	40		40
Track Rollers, Each Side	7		7
Track Length on Ground	2349 mm (92 in.)		2349 mm (92 in.)
Ground Contact Area	21 479 cm ² (3,329 sq. in.)	33 412 cm ² (5,179 sq. in.)	
Ground Pressure	44.1 kPa (6.4 psi)	29.6 kPa (4.3 psi)	
Track Pitch	171 mm (6.7 in.)	171 mm (6.7 in.)	
Operator Station		650K XLT / 650K LGP	
ROPS (ISO 3471 – 2008) and FOPS (ISO 3449 – 2005)			
Serviceability			
Refill Capacities			
Fuel Tank with Lockable Cap	202 L (53.45 gal.)		
Diesel Exhaust Fluid (DEF) Tank	11.8 L (3.1 gal.)		
Cooling System with Recovery Tank	21.1 L (5.6 gal.)		
Engine Oil with Filter	19 L (20 qt.)		
Hydraulic/HST Oil (common reservoir) with Filters	100 L (26.42 gal.)		
Final Drive (per tractor)	17 L (4.6 gal.)		
Operating Weights		650K XLT	650K LGP
Blade Type	PAT		PAT
<i>Base Weight (with standard equipment, rollover protective structure [ROPS], full fuel tank, and 79-kg [175 lb.] operator)</i>	9691 kg (21,320 lb.)	10 156 kg (22,343 lb.)	
Optional Components			
Cab with Pressurizer and Heater/Air Conditioner	306 kg (675 lb.)	306 kg (675 lb.)	
ROPS Canopy			
Heater	39 kg (85 lb.)	39 kg (85 lb.)	
Front and Door Screens	81 kg (179 lb.)	81 kg (179 lb.)	
Rear Screen	34 kg (76 lb.)	34 kg (76 lb.)	
Side Screens	43 kg (94 lb.)	43 kg (94 lb.)	
Limb Risers (ROPS canopy and cab)	104 kg (229 lb.)	104 kg (229 lb.)	
Counterweight			
Front	109 kg (240 lb.)	109 kg (240 lb.)	
Rear	150 kg (330 lb.)	150 kg (330 lb.)	
Retrieval Hitch	23 kg (50 lb.)	23 kg (50 lb.)	
Drawbar, Extended Rigid	33 kg (72 lb.)	33 kg (72 lb.)	
Winch	652 kg (1,437 lb.)	652 kg (1,437 lb.)	
Fairlead, 4 Roller	85 kg (187 lb.)	85 kg (187 lb.)	
Center Chain Guides	41 kg (90 lb.)	41 kg (90 lb.)	
Full-Length Rock Guards	98 kg (216 lb.)	98 kg (216 lb.)	
Maximum Life Undercarriage	182 kg (400 lb.)	182 kg (400 lb.)	
Track Shoes			
457 mm (18 in.)	In base	—	
510 mm (20 in.)	83 kg (183 lb.)	–344 kg (–760 lb.)	
610 mm (24 in.)	—	–172 kg (–380 lb.)	
710 mm (28 in.)	—	In base	

Machine Dimensions	650K XLT / 650K LGP
A Overall Height to Roof	2762 mm (9 ft. 1.25 in.)
B Tread Depth with Single-Bar Grouser	49 mm (1.9 in.)
C Ground Clearance in Dirt	341 mm (13.5 in.)
D Overall Length	4255 mm (168 in.) (14 ft. 0 in.)
E Blade Lift Height	818 mm (32.2 in.)
F Blade Digging Depth	500 mm (19.7 in.)
G Blade Cutting-Edge Angle, Adjustable	52 to 60 deg.

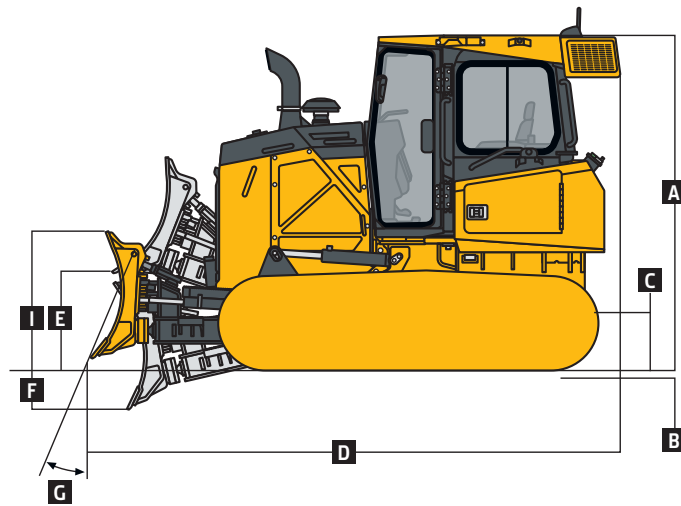

650K XLT / 650K LGP WITH POWER-ANGLE-TILT (PAT) BLADE

Machine Dimensions (continued)	650K XLT	650K LGP
Blade Type	PAT	PAT
Straight		
H Blade Width	2667 mm (105 in.) (8 ft. 9 in.)	2921 mm (115 in.) (9 ft. 7 in.)
I Blade Height	1067 mm (3 ft. 6 in.)	955 mm (3 ft. 2 in.)
SAE Capacity	2.2 m ³ (2.9 cu. yd.)	2.0 m ³ (2.6 cu. yd.)
Weight	603 kg (1,330 lb.)	628 kg (1,385 lb.)
C-Frame Assembly Weight (without blade)	399 kg (879 lb.)	399 kg (879 lb.)
J Blade Angle	22.2 deg.	22.2 deg.
K Overall Width with Blade Angled	2469 mm (8 ft. 1 in.)	2705 mm (8 ft. 11 in.)
L Blade Tilt (uses tilt jack)	363 mm (14.3 in.)	399 mm (15.7 in.)
M Cut Reach	117 mm (4.6 in.)	5 mm (0.2 in.)
N Width Over Track	2007 mm (6 ft. 7 in.)	2464 mm (8 ft. 1 in.)
O Cast Reach	345 mm (13.6 in.)	236 mm (9.3 in.)
Straight (option)		
H Blade Width	2921 mm (115 in.) (9 ft. 7 in.)	3150 mm (124 in.) (10 ft. 4 in.)
I Blade Height	955 mm (3 ft. 2 in.)	894 mm (35 in.)
SAE Capacity	2.0 m ³ (2.6 cu. yd.)	1.9 m ³ (2.5 cu. yd.)
Weight	628 kg (1,385 lb.)	631 kg (1,391 lb.)
C-Frame Assembly Weight (without blade)	399 kg (879 lb.)	399 kg (879 lb.)
J Blade Angle	22.2 deg.	22.2 deg.
K Overall Width with Blade Angled	2705 mm (8 ft. 11 in.)	2916 mm (9 ft. 7 in.)
L Blade Tilt (uses tilt jack)	399 mm (15.7 in.)	429 mm (16.9 in.)
M Cut Reach	234 mm (9.2 in.)	112 mm (4.4 in.)
N Width Over Track	2007 mm (6 ft. 7 in.)	2464 mm (8 ft. 1 in.)
O Cast Reach	465 mm (18.3 in.)	340 mm (13.4 in.)

Machine Dimensions (continued)	650K XLT	650K LGP
Blade Type	PAT	PAT
Straight (option)		
H Blade Width	3150 mm (124 in.) (10 ft. 4 in.)	3251 mm (128 in.) (10 ft. 8 in.)
I Blade Height	894 mm (35 in.)	955 mm (3 ft. 2 in.)
SAE Capacity	1.9 m ³ (2.5 cu. yd.)	2.2 m ³ (2.9 cu. yd.)
Weight	631 kg (1,391 lb.)	694 kg (1,530 lb.)
C-Frame Assembly Weight (without blade)	399 kg (879 lb.)	399 kg (879 lb.)
J Blade Angle	22.2 deg.	22.2 deg.
K Overall Width with Blade Angled	2916 mm (9 ft. 7 in.)	3010 mm (9 ft. 11 in.)
L Blade Tilt (uses tilt jack)	429 mm (16.9 in.)	445 mm (17.5 in.)
M Cut Reach	340 mm (13.4 in.)	157 mm (6.2 in.)
N Width Over Track	2007 mm (6 ft. 7 in.)	2464 mm (8 ft. 1 in.)
O Cast Reach	569 mm (22.4 in.)	569 mm (22.4 in.)

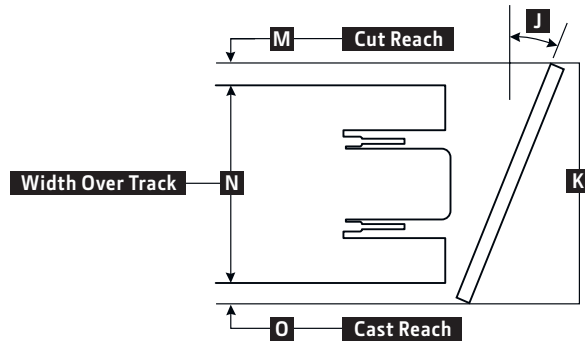
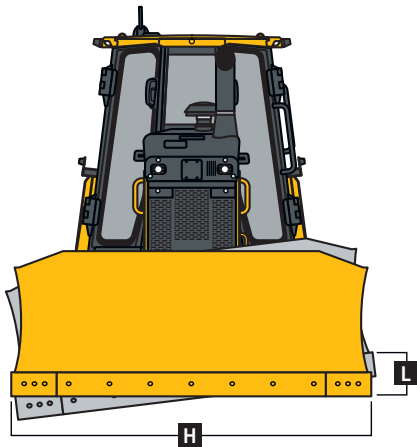

Rear Ripper	650K XLT / 650K LGP
Blade Type	PAT
Multi-shank parallelogram ripper with 5 pockets and 3 shanks	
Weight	981 kg (2,163 lb.)
P Maximum Penetration	508 mm (20 in.)
Q Maximum Clearance Under Tip	508 mm (20 in.)
R Overall Length, Lowered Position	1450 mm (57 in.) (4 ft. 9 in.)
R' Overall Length, Raised Position	1015 mm (40 in.) (3 ft. 4 in.)
S Overall Beam Width	1830 mm (6 ft. 0 in.)
T Slope Angle (full raise)	40 deg.
U Ripping Width	1670 mm (5 ft. 6 in.)
V Distance Between Shanks	806 mm (32 in.)

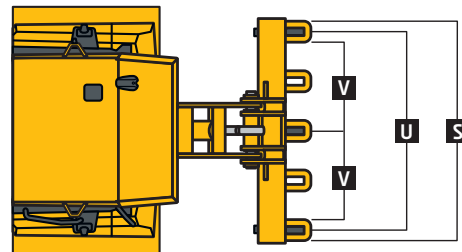
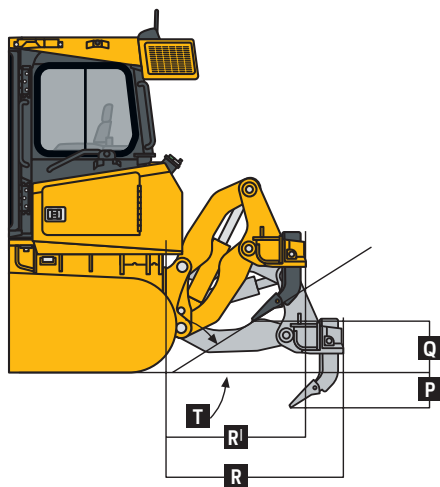

Additional equipment

Key: ● Standard ▲ Optional or special

*See your John Deere dealer for further information.

450K	550K	650K	Engine
●	●	●	Meets EPA Final Tier 4/EU Stage IV emissions
●	●	●	Electronic control with automatic engine protection
●	●	●	Dual safety element dry-type air cleaner, evacuator valve
●	●	●	Exhaust filter, under hood, with vertical stack
●	●	●	Engine glow-plug starting system
●	●	●	Programmable auto engine shutdown
●	●	●	Automatic turbo cool-down timer
●	●	●	Wet-sleeve cylinder liners
●	●	●	Remote-mounted fuel filters with automatic electronic priming
▲	▲	▲	Engine coolant heater, 110 volts
▲	▲	▲	Engine coolant heater, fuel fired
▲	▲	▲	Chrome exhaust
▲	▲	▲	Rotary ejector engine air pre-cleaner
▲	▲	▲	Fluid-sample valves
▲	▲	▲	Quick-service ports
▲	▲	▲	Severe-duty 400-mL (13.5 oz.) fuel filter and water separator with heating element
			Cooling
●	●		Blower-type, direct-drive cooling fan
		●	Variable-speed suction fan with optional reversing feature
		▲	Automatic, programmable reversing-fan-drive fan
●	●	●	Enclosed safety fan guard (conforms to SAE J1308 and ISO3457)
●	▲	▲	Perforated engine side shields
●	●	●	Heavy-duty perforated grille
●	●	●	Heavy-duty, trash-resistant radiator and high-ambient cooling package
▲	▲	▲	Extreme-duty perforated grille with light guard
			Powertrain
●	●	●	Remote diagnostic test ports
●	●	●	Automatic cold-weather transmission warmup system
●	●	●	Automatic transmission derating for exceeded system temperatures
▲	●	●	Environmental service drains
●	●	●	2,000-hour vertical spin-on transmission filter
			Hydraulic System
●	●	●	3-function hydraulics
●	●	●	2,000-hour vertical spin-on hydraulic filter
▲	▲	▲	4-function hydraulics with rear plumbing

450K	550K	650K	Hydraulic System (continued)
▲	▲	▲	Drive-through hydraulic pump for use with winch
▲	▲	▲	Grade-control-ready electrohydraulics (EH)
▲	▲	▲	Integrated Grade Control (IGC)
▲	▲	▲	Topcon IGC
			Mainframe, Access Panels
●	●	●	Front tow loop, bolt-on
●	●	●	Reinforced engine and mid-frame bottom guards
●	●	●	Integral transmission guard
●	●	●	Vandal protection: Engine access door / Side tank access doors / Fuel tank / Instrument panel / Transmission reservoir / Hydraulic reservoir
			Attachments
▲	▲	▲	Counterweight, front, 109 kg (240 lb.)
▲	▲	▲	Counterweight, rear, 150 kg (330 lb.)
▲	▲	▲	Retrieval hitch with pin
▲	▲	▲	Extended rigid drawbar with pin for pull-type implements
▲	▲	▲	Drawbar, extended for winch (with or without fairlead)
▲	▲	▲	Ripper, parallelogram with 5 shank pockets and 3 teeth
▲	▲	▲	Winch, John Deere, power in/free spool out OR power out
▲	▲	▲	4-roller fairlead for winch
▲	▲	▲	Root-rake blade attachment
▲	▲	▲	Rear-mounted toolbox
▲	▲	▲	Trimble-ready interface package
▲	▲	▲	Topcon-ready interface package
▲	▲	▲	Leica-ready interface package
			Undercarriage
●	●	●	Full-length, smooth-surface track frame covers
●	●	●	Chain guides, front and rear
●	●	●	Maximum Life Undercarriage System
▲	▲	▲	Extended life undercarriage (SC-2™ bushings)
▲	▲	▲	Heavy-duty sealed and lubricated undercarriage
▲	▲	▲	Full-length rock guards
			STD LGP 450K Shoes
●			406-mm (16 in.) moderate service
	●		610-mm (24 in.) moderate service
			STD LGP 550K Shoes
●	▲		457-mm (18 in.) moderate service
	●		610-mm (24 in.) moderate service

XLT	LGP	650K Shoes
●	▲	457-mm (18 in.) moderate service
▲	▲	510-mm (20 in.) moderate service with clipped corners
	▲	610-mm (24 in.) moderate service
	●	710-mm (28 in.) moderate service with clipped corners
		Canopy Cab Operator's Station / Electrical
●	●	Retractable seat belts, 76 mm (3 in.) (conform to SAE J386)
●	●	Accessories: Convex wide-angle interior rearview mirror / Thigh cushions (2) / Cup holders (2)
●	●	Power port (cab includes two power ports)
●	●	Lockable dash-mounted storage compartment
	●	Air conditioner, 24,000 Btu
	●	Tinted glass
	●	Dome light
	●	Heater (roof mount)
	●	Wipers (intermittent plus 2 speeds) and washers – front window, left and right doors
	▲	Rear wiper and washer
●		Air-ride vinyl seat
	●	Air-ride fabric seat
	▲	Deluxe heated and leather-bolstered air-ride seat
▲	●	Under-seat heater
	●	AM/FM, weather-band radio, clock, and MP3 player front plug-in
	▲	Satellite Radio™, USB port, and Bluetooth® mic
	●	Radio-area storage slot
●	●	Sealed alternator, 100 amps
●	●	Lockable master electrical disconnect switch
●	●	Multifunction/multi-language LCD monitor: Analog display (fuel level, coolant temperature, and engine oil pressure) / Digital display (engine rpm, charge pressure, hours, DPF soot level, and transmission direction/speed range)
●	●	Built-in diagnostics: Diagnostic-code details / Sensor values / Calibrations / Individual circuit tester
●	●	Keyless start with multiple security modes
●	●	Battery, dual, 24 volts
●	▲	Lights, grille mounted (2), rear mounted (2)
▲	▲	Work lights, roof mounted (2)
	▲	External-mounted attachment mirror
●	●	JDLINK™ Ultimate wireless communication system (available in specific countries; see your dealer for details)



Net engine power is with standard equipment including air cleaner, exhaust system, alternator, and cooling fan at test conditions specified per ISO9249. Specifications and design subject to change without notice. Wherever applicable, specifications are in accordance with SAE standards. Except where otherwise noted, these specifications are based on units with standard equipment, rollover protective structures (ROPS), full fuel tanks, and 79-kg (175 lb.) operators.