

1050K DOZER

261 kW (350 hp)



JOHN DEERE



When you weigh all your options, you'll choose a 1050K.

We don't take our customers' opinions lightly. So when owners and operators like you weighed in with fresh insights on our reimagined 1050K Dozer, we listened and responded with additional weight and power for more productivity. Other enhancements include an EPA Final Tier 4 (FT4)/EU Stage IV diesel engine for work in nonattainment areas. And a new Eco mode that regulates engine rpm to burn up to 25-percent less fuel. Plus the unsurpassed visibility, operating ease, responsiveness, and reliability you've come to expect from our crawlers. When you compare it to other crawlers in its class, the 1050K is the obvious choice.



Key Specifications	1050K
Net power	261 kW (350 hp)
Operating weight	42 800–43 100 kg (94,300–95,000 lb.)
Track length on ground	3419 mm (134.6 in.)
Grouser widths	610, 660, and 711 mm (24, 26, and 28 in.)
Blade width (Semi-U or U)	3964 mm (156 in.) (13 ft. 0 in.)



Power when you need it. Control the way you want it.

Boasting more power and weight than the J-Series model it replaces, the 1050K Dozer delivers the performance you need for mining, quarrying, road building, and other large-scale applications. From the ground up, the completely redesigned 1050K features a John Deere engine with superior power-to-weight ratio to provide the traction needed to push more material. Dual-path hydrostatic transmission allows you to push a full load through turns without losing material, unlike torque-converter transmissions on competitor machines. You'll get more done without a lot of extra effort because nothing runs like this Deere.

Thanks to electrohydraulic (EH) controls, the 1050K Dozer is grade-control ready, making adding a system as easy as plugging in the components, calibrating, and going to work, whether your preferred system is Trimble or Topcon.

Blade pitch is adjustable to three mount locations, for superior performance in a variety of applications and materials.

Hydraulic power-pitch option allows the operator to control blade pitch from the cab — perfect for applications where pitch must be adjusted multiple times in a single push. Using programmable return-to-pitch settings, the operator can preset blade-pitch positions, which can be activated at the touch of a button.

Slow-running FT4/Stage IV diesels deliver impressive power, torque, and drawbar pull for unsurpassed productivity.

Power turns, power management, infinite speed control — John Deere introduced them all more than 35 years ago. And the 1050K Dozer is loaded with even more productivity- and uptime-boosting enhancements.

Simply set maximum desired ground speed, and the power-management system automatically maintains peak engine rpm and power efficiency without stalling or shifting.

Low-effort controls command the redesigned blade curvature and full-featured hydrostatic drivetrain, ensuring predictable response at all times, in all conditions.



1. Variable-pitch parallelogram single- or triple-shank ripper can be angled on the go, for increased productivity.





2. Independent track control speeds up or slows down each side — for smooth, full-power turns.

3. Counterrotation is another productivity-boosting feature. It enables an operator to overcome heavy corner loads and quickly reposition the blade on the go. Provides space-saving spot turns, too.

4. This crawler steers the same and maintains its preset speed whether working on level ground or a 2-to-1 slope. So there's never a need to cross-steer or ride a brake.

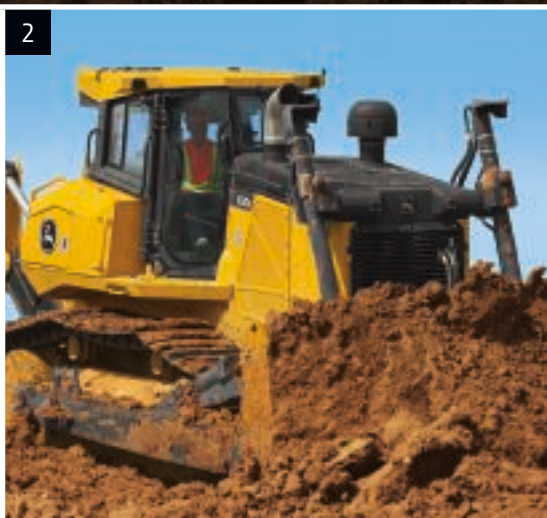

Find your comfort zone.

Who wouldn't be more productive in the 1050K's noticeably quiet and spacious walk-through cab? This dozer is loaded with all the fatigue-beating amenities an operator needs to get "in the zone" and become more productive.



1. Beyond cup holders and cooler storage, there are plenty of places to store stuff. If you're running a grade-control system, the lockable in-dash compartment is ideal for end-of-day storage (or permanent placement) of the monitor. Overhead radio and storage console includes a 12-volt electrical outlet for powering a cell phone or an iPod®.

2. Ergonomically correct joystick provides intuitive, low-effort control of steering, direction, and ground speed. It's detented so it doesn't require an operator's constant touch or attention, and employs a thumb-actuated travel-speed-control switch.

3. Exclusive Total Machine Control (TMC) monitor lets an operator select decelerator mode and response, forward/reverse ground-speed ranges, steering modulation, F-N-R shift rate, and forward/reverse speed ratios.



Bogie undercarriage absorbs shock and vibration to smooth the ride over rough terrain, helping minimize fatigue while maximizing productivity.

Like all Deere dozers, hydrostatic drivetrain controls deliver predictable response at all times to ensure smooth moves, virtually eliminating jerky and abrupt movements.

Use the decelerator to slow both ground speed and engine rpm, or ground speed only, to help maintain traction without affecting engine power and hydraulic response. Fully depressing the pedal applies the brakes.

Deluxe suspension high-back seat is angled 15 deg. to provide a more comfortable view of the ripper. The seat adjusts seven ways for daylong comfort. Arm- and footrests are also fully adjustable to fit any size operator.

Numerous directional vents keep the glass clear and interior comfortable. For models equipped with only a Rollover Protective Structure (ROPS), an optional under-seat heater helps warm the operator.

Sealed-switch module gives fingertip control of keyless start. Touchpad security system requires a numeric pass code (when enabled) to help prevent unauthorized machine operation.

The enhanced multifunction LCD color monitor provides pushbutton access to a wealth of machine info. It also enables you to customize machine settings.

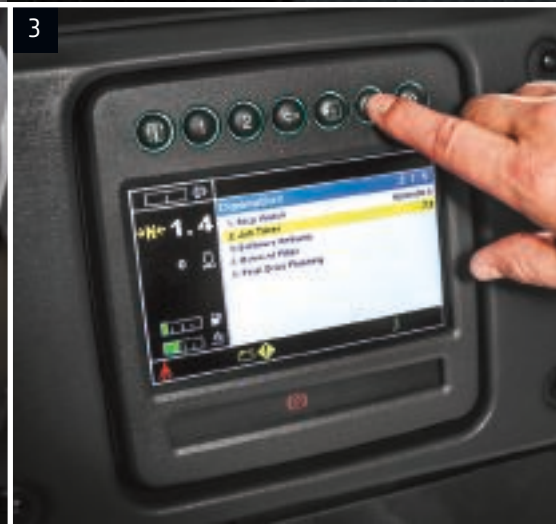



Nothing runs like a Deere, because nothing is built like one.

The 1050K was designed and built with state-of-the-art tools and techniques by a quality-conscious workforce at our world-class facility in Dubuque, Iowa. The 1050K shares many reliable components with our other K-Series Dozers, including an exceptionally strong unitized mainframe, a heavy-duty wet-sleeve engine, and isolated planetary final drives. When you know how they're built, you'll run a Deere.

John Deere WorkSight™ is a powerful suite of telematics solutions that optimizes machines, uptime, and jobsites. At its heart, JDLink™ monitoring provides real-time machine-location and -utilization data, and enables machine-health prognostics that suggest maintenance solutions to prevent costly downtime.

Most wear parts such as cutting edges and end bits are interchangeable with other competitive machines, so you only have to stock one part if you run a mixed fleet.

Oscillating track frames absorb shock loads, for lasting durability, better gradeability, and more comfort. Plus a smaller-diameter front idler improves visibility.

Final-drive temperature can be monitored and reported using JDLink to help identify issues before they become more serious problems.

Half-shell push-beam bearings make cutting and welding unnecessary, so they're less costly and time-consuming to replace.



1. Flush-fit bottom guards and tight-fitting side shields help keep trash out. Hood and side-shield perforations function as “first filters,” further preventing entry of most debris.
2. Heavy-duty undercarriage is sealed, lubricated, and built to last. Its no-nonsense oval-track design has only one wear-causing forward-travel flex point, for longer life.
3. Cooling package is designed to perform in all conditions, including high ambient temperatures. Reversing fan automatically back-blows the cooler cores at preset intervals. When conditions demand more frequent cleaning, simply press a button to actuate the reversing cycle.



John Deere PowerTech™ FT4/Stage IV diesel engine meets emission regulations without sacrificing power or torque. We built on our EPA Interim Tier 4 (IT4)/EU Stage IIIB solution to deliver the best combination of performance, efficiency, and reliability. Our field-proven technology is simple, fluid efficient, fully integrated, and fully supported. It employs cooled exhaust gas recirculation (EGR), easy-to-maintain high-uptime exhaust filters, and selective catalytic reduction (SCR).

One-piece welded mainframe resists torsional stress, absorbs shock loads, and delivers maximum strength while allowing easy service access to major components. Heavy-duty double-reduction planetary final drives are mounted independent of the track frames, where they're effectively protected from shock loads.

What if your dealer could warn you of problems with your machine and initiate solutions without visiting the jobsite and charging you for a technician's travel time? That's what you get with John Deere WorkSight's exclusive remote diagnostics and programming.

Maintaining big iron doesn't have to be a big deal.

Servicing a production-class machine shouldn't be a big production. And it isn't on a 1050K. Swing open the large hinged doors, and you'll discover the many ways this dozer minimizes maintenance. Access to dipsticks, fill tubes, maintenance-free batteries, and vertical filters is wide open. Convenient same-side service points make quick work of the daily routine. Even gaining access to drivetrain components takes only minutes.

Standard Eco mode maximizes fuel economy without sacrificing performance, automatically adjusting engine rpm and transmission settings based on load.

Auto-idle automatically reduces engine speed when the machine is not moving and no functions are active. Exclusive auto shutdown turns off the engine after extended inactivity.

Sealed hydraulic and hydrostatic reservoirs are separate, eliminating any possibility of cross-contamination.

Ash-service intervals for the diesel particulate filter (DPF) are condition based, meaning the machine will notify the operator before service is required. Typically, ash service is not necessary until the first engine overhaul. Machine application, regular maintenance practices, and type of lubricating oil impact ash-service intervals.

Cooler design provides wide-open access for easy cleanout, minimizing plugging. Standard reversing fan automatically back-blows the cooler cores at preset intervals. When conditions demand more frequent cleaning, simply press a button to actuate the reversing cycle.

Smooth idler-to-sprocket covers shed material, with wide space between the track frames and mainframe further easing cleanout.

Remote lube banks provide easy access for lubrication of crossbar and C-frame pivots.

Available quick-fluid evacuation system helps speed servicing. 500-hour engine oil and 2,000-hour transmission and hydraulic fluid intervals decrease downtime and expense.

Ultimate Uptime, featuring John Deere WorkSight, is a customizable support solution available exclusively from your Deere dealer. This flexible offering maximizes equipment availability with standard John Deere WorkSight capabilities that can help prevent future downtime and speed repairs when they do occur. In addition to the base John Deere WorkSight features, our dealers work with you to build an uptime package that meets the specific needs of your machine, fleet, project, and business, including customized maintenance and repair agreements, onsite parts availability, extended warranties, fluid sampling, response-time guarantees, and more.



1. Large hinged doors provide ample access for easy everyday checks and periodic maintenance. Daily service is limited to hydraulic-oil and engine-oil and -coolant levels. Operator station tilts a full 70 deg. in only minutes, for wide-open drivetrain-component access.

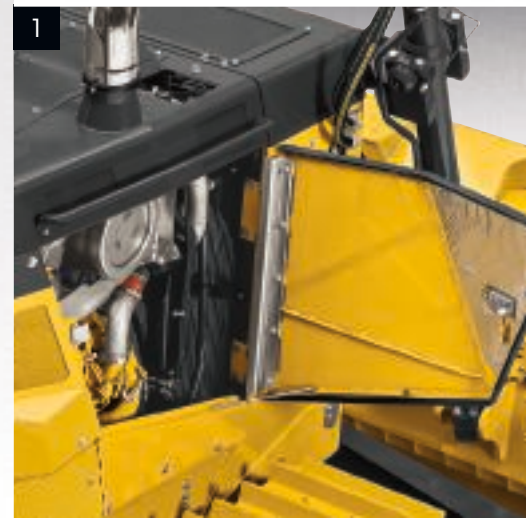



2. Fast-fuel and quick-fluid-service options help maximize uptime while ensuring clean refills — perfect for high-hour nonstop applications and environmental areas that are highly regulated.

3. Fluid-sample and diagnostic test ports simplify preventive-maintenance work and troubleshooting, for increased uptime.

4. Vertical filters allow quick, no-spill changes. Engine, hydraulics, and transmission utilize a common oil, further simplifying service.

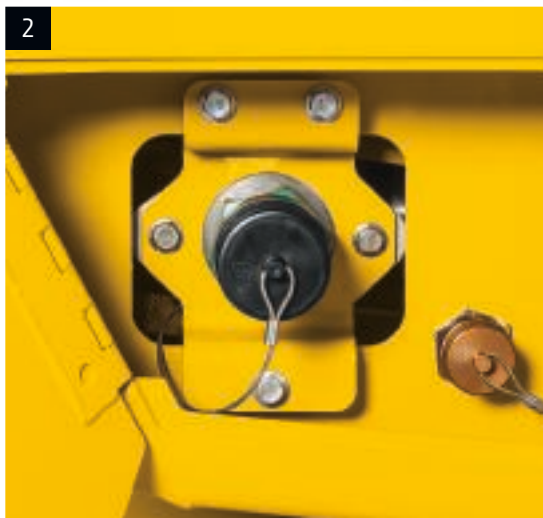

1050K

Engine	1050K OUTSIDE DOZER (OSD)
Blade Type	<i>Semi-U Blade / U Blade</i>
Manufacturer and Model	John Deere PowerTech™ PSS 6135
Non-Road Emission Standard	EPA Final Tier 4/EU Stage IV
Displacement	13.5L (824 cu. in.)
SAE Net Rated Power	236 kW (317 hp) at 2,000 rpm
Net Peak Torque	1576 Nm (1,162 lb.-ft.) at 1,300 rpm
Aspiration	Turbocharged and air-to-air aftercooled
Air Cleaner	Dual-element dry canister with external rotary ejector precleaner
Cooling	
Type	Variable-speed suction fan with automatic reversing
Engine Coolant Rating	-37 deg. C (-34 deg. F)
Engine Radiator	8 fins per in.
Powertrain	
Transmission	Automatic, dual-path, hydrostatic drive; load-sensing feature automatically adjusts speed and power to match changing load conditions; each individually controlled track is powered by a variable-displacement piston pump and motor combination; ground-speed selection buttons on single-lever steering and direction control; independently selectable reverse speed ratios of 100%, 115%, or 130% of forward ground speed; decelerator pedal controls ground speed to stop
System Relief Pressure	45 850 kPa (6,650 psi)
Travel Speeds	
Forward and Reverse	11 km/h (6.8 mph)
Maximum (optional)	11 km/h (6.8 mph)
Steering	Single-lever steering, direction control, and counterrotation; full power turns and infinitely variable track speeds provide unlimited maneuverability and optimum control; hydrostatic steering eliminates steering clutches and brakes
Final Drives, Total Ratio	51.337
Drawbar Pull	
Maximum	623 kN (140,000 lb.)
At 1.9 km/h (1.2 mph)	332 kN (74,600 lb.)
At 3.2 km/h (2.0 mph)	208 kN (46,700 lb.)
Brakes	
Service	Hydrostatic (dynamic) braking stops machine whenever the direction/steering control lever is moved to neutral or the decelerator is depressed to the end of travel
Parking	Exclusive safety feature engages wet, multiple-disc brakes whenever the engine stops, the decelerator is depressed to the end of travel, or the park lock lever is placed in the start or neutral positions and motion is detected; machine cannot be driven with brake applied, reducing wearout or need for adjustment; spring applied, hydraulic release
Hydraulics	
Type	Load-sensing electrohydraulic (EH) system variable-displacement piston pump
Pump Displacement	145 cc
System Relief Pressure	24 993 kPa (3,625 psi)
Differential Pressure	1896 kPa (275 psi)
Maximum Flow at Unloaded High Idle	308 L/m (81 gpm)
Control	2-function EH T-bar joystick

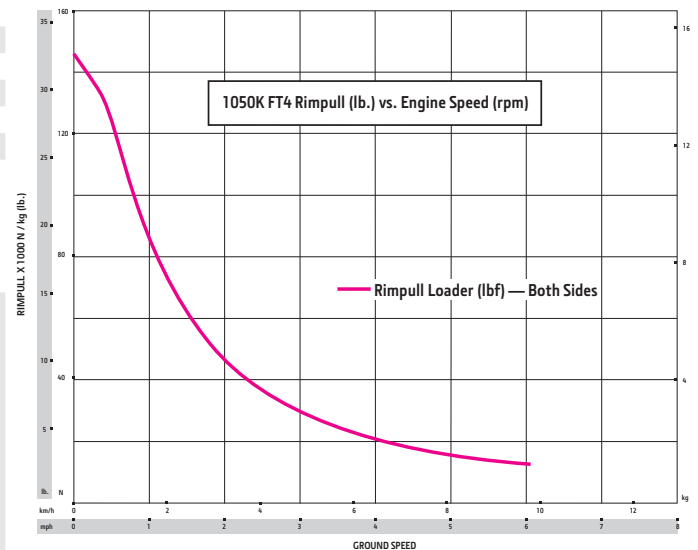



Electrical	1050K OSD	
Voltage	24 volts	
Capacity		
Battery	950 CCA	
Reserve	190 min.	
Alternator Rating	130 amp	
Lights	Cylinder mounted (2), rear-mounted cab (2), roof-mounted forward facing (2), engine compartment (1), and rear reflectors (2)	
Undercarriage		
Blade Type	<i>Semi-U Blade / U Blade</i>	
Tracks	Track frame includes bogie undercarriage design with sealed track-adjuster cavity, front and rear track guides, and sprocket guard; John Deere Dura-Trax™ features deep-heat-treated, sealed, and lubricated track links and through-hardened, sealed, and lubricated rollers for maximum wear resistance; sprockets are segmented; track shoes are extreme duty	
Track Gauge	2184.4 mm (86 in.)	
Grouser Width	610 mm (24 in.)	
Chain	Sealed and lubricated	
Shoes, Each Side	46	
Track Rollers, Each Side	8	
Track Length on Ground	3419 mm (134.6 in.)	
Ground Contact Area	41 684 cm ² (6,462 sq. in.)	
Ground Pressure	101 kPa (14.6 psi)	
Track Pitch	215.9 mm (8.5 in.)	
Operator Station		
	ROPS (ISO 3471 – 2008) and FOPS (ISO 3449 – 2005)	
Serviceability		
Refill Capacities		
Fuel Tank with Lockable Cap	681 L (180 gal.)	
Diesel Exhaust Fluid (DEF) Tank	22.9 L (6.1 gal.)	
Cooling System with Recovery Tank	73.5 L (19.4 gal.)	
Engine Oil with Filter	43.5 L (11.5 gal.)	
Reservoir with Filter (oil volume of tank only)		
Transmission	149 L (39.44 gal.)	
Hydraulic	87 L (23 gal.)	
Operating Weights		
Blade Type	<i>Semi-U Blade</i>	<i>U Blade</i>
Base Weight (includes standard equipment, rollover protective structure [ROPS], single-shank ripper, 610-mm [24 in.] track shoes, full fuel tank, and 79-kg [175 lb.] operator)	42 800 kg (94,300 lb.)	43 100 kg (95,000 lb.)
Optional Components	<i>Semi-U Blade / U Blade</i>	
Front and Door Screens	61 kg (135 lb.)	
Rear Screen	36 kg (80 lb.)	
Side Screens	41 kg (90 lb.)	
Condenser Guard	19 kg (42 lb.)	
Limb Risers	755 kg (1,664 lb.)	
Rear Counterweight	2232 kg (4,921 lb.)	
Retrieval Hitch (standard drawbar on counterweight)	65 kg (143 lb.)	
Winch (includes 3-roller fairlead)	1905 kg (4,200 lb.)	
Winch-Mounting Plate	1115 kg (2,458 lb.)	
Heating, Ventilating, and Air-Conditioning (HVAC)-Powered Precleaner	20 kg (44 lb.)	
Track Shoes		
610 mm (24 in.) Extreme Duty or Trapezoidal	Extreme duty in base	
660 mm (26 in.) Extreme Duty or Trapezoidal	249 kg (548 lb.)	
710 mm (28 in.) Extreme Duty or Trapezoidal	497 kg (1,096 lb.)	

Machine Dimensions		1050K OSD	
Blade Type		<i>Semi-U Blade</i>	<i>U Blade</i>
A	Overall Height to Roof	3476 mm (11 ft. 5 in.)	3476 mm (11 ft. 5 in.)
B	Tread Depth with Single-Bar Grouser, Extreme Duty or Trapezoidal	85 mm (3.3 in.)	85 mm (3.3 in.)
C	Ground Clearance in Dirt (includes grouser height)	537 mm (21 in.)	537 mm (21 in.)
D Overall Length			
	With Blade and Ripper	8780 mm (28 ft. 10 in.)	9093 mm (29 ft. 10 in.)
	With Blade and Winch with Fairlead Rollers	7738 mm (25 ft. 5 in.)	8184 mm (26 ft. 10 in.)
D^I	Overall Length with Blade	6678 mm (21 ft. 11 in.)	6991 mm (22 ft. 11 in.)
D^{II}	Overall Length without Ripper and Blade	5137 mm (16 ft. 10 in.)	5137 mm (16 ft. 10 in.)
E	Blade Lift Height	1099 mm (3 ft. 7 in.)	1099 mm (3 ft. 7 in.)
F	Blade Digging Depth	707 mm (28 in.)	707 mm (28 in.)
G Blade Cutting-Edge Angle			
	Standard	53.5 to 59.5 deg.	53.5 to 59.5 deg.
	Power Pitch	52.6 to 60.4 deg.	52.6 to 60.4 deg.
H	Blade Width	3964 mm (156 in.) (13 ft. 0 in.)	3964 mm (156 in.) (13 ft. 0 in.)
I Blade Height			
	SAE Capacity	9.7 m ³ (12.7 cu. yd.)	11.4 m ³ (14.9 cu. yd.)
	Blade Weight	2726 kg (6,010 lb.)	3400 kg (7,490 lb.)
	Push-Beam Assembly Weight (without blade)	2960 kg (5,930 lb.)	2960 kg (5,930 lb.)
J Blade Tilt			
	Width Over Track (no trunnions)	2895 mm (9 ft. 6 in.)	2895 mm (9 ft. 6 in.)
	Width Over Trunnions	3408 mm (11 ft. 2 in.)	3408 mm (11 ft. 2 in.)

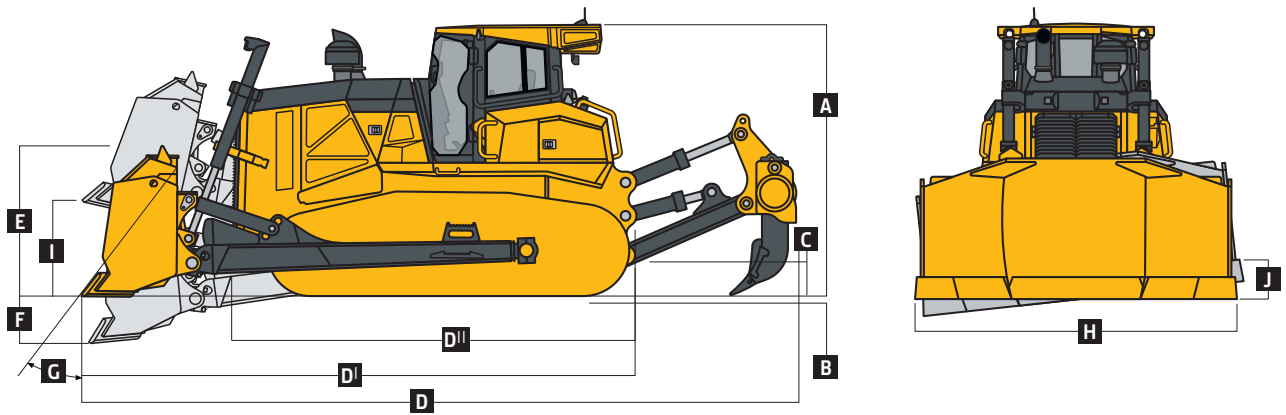

Rear Ripper		1050K OSD	
Blade Type	Semi-U Blade / U Blade		
Ripper Type	Single Shank	Multi Shank	
Weight	3793 kg (8,362 lb.)	4586 kg (10,110 lb.)	
K Maximum Penetration	1102 mm (3 ft. 7 in.)	780 mm (31 in.)	
L Maximum Clearance Under Tip	727 mm (29 in.)	689 mm (27 in.)	
M Added Length, Lowered (transport) Position	2260 mm (7 ft. 5 in.)	2116 mm (7 ft. 0 in.)	
M' Added Length, Raised Position	1880 mm (6 ft. 2 in.)	1745 mm (5 ft. 9 in.)	
N Overall Beam Width	1418 mm (4 ft. 8 in.)	2527 mm (8 ft. 4 in.)	
O Slope Angle (full raise)	26 deg.	25 deg.	
P Ripping Width	—	2184 mm (7 ft. 2 in.)	
Q Distance Between Shanks	—	1092 mm (3 ft. 7 in.)	

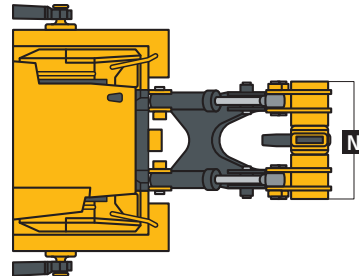
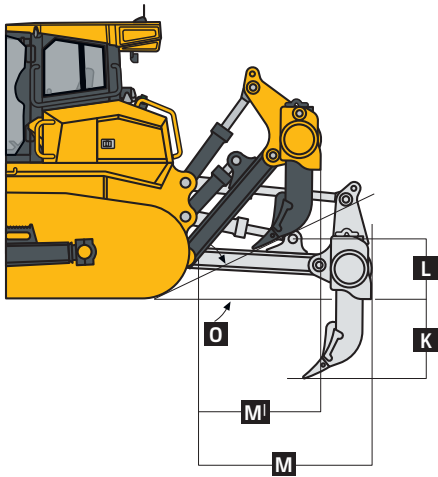

1050K DOZER WITH SINGLE-SHANK REAR RIPPER

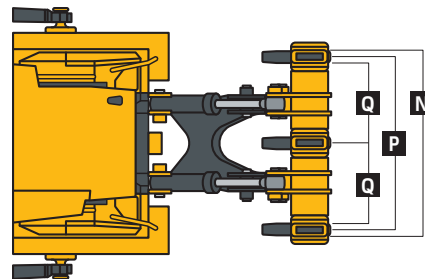
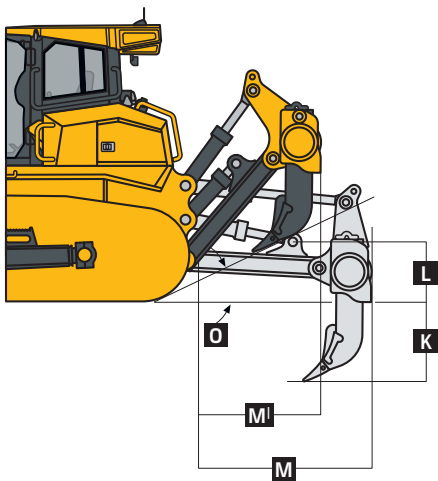

1050K DOZER WITH MULTI-SHANK REAR RIPPER

Additional equipment

Key: ● Standard ▲ Optional or special

See your John Deere dealer for further information.

1050K Engine

- Meets EPA Final Tier 4/EU Stage IV emissions
- John Deere PowerTech™ PSS 6135 13.5L engine
- Wet-sleeve cylinder liners
- Eco mode
- Exhaust stack, black
- ▲ Exhaust stack, chrome
- Electronic control with automatic engine protection
- Turbocharged and air-to-air aftercooled
- Dual-element dry canister with external rotary ejector precleaner
- Programmable auto engine shutdown
- Automatic turbo cool-down timer
- ▲ Severe-duty fuel lines and fittings
- Engine coolant heater, 120V
- 130-amp alternator

Cooling

- Engine coolant rated -37 deg. C (-34 deg. F)
- Automatic, programmable reversing fan
- Engine radiator, 8 fins per in.

Powertrain

- Dual-path hydrostatic (HST) transmission
- Selectable reverse-speed ratios
- Operator-selectable decelerator function (hydrostats and engine or hydrostats only)
- Single-lever steering with counter-rotate function
- Full power turns with infinitely variable track speed
- HST (dynamic) service brakes
- Wet, multi-disc parking brake

Hydraulics

- Load-sense electrohydraulic (EH) system with variable-displacement piston pump
- ▲ 2-spool EH control valve for outside dozer
- ▲ 3-spool EH control valve for outside dozer with single auxiliary
- ▲ 3-spool EH control valve, auxiliary only

1050K Hydraulics (continued)

- ▲ 4-spool EH control valve for outside dozer with dual auxiliary
- ▲ 5-spool EH control valve for outside dozer with triple auxiliary
- Hydrau™ All-Season Hydraulic Oil, -25 deg. C to 50 deg. C (-13 deg. F to 122 deg. F)
- ▲ Hydrau™ XR Hydraulic Oil, -40 deg. C to 40 deg. C (-40 deg. F to 104 deg. F)
- ▲ Power pitch for outside dozer
- ▲ Hydraulic-winch-ready kit

Undercarriage

- Bogie undercarriage design
- Sealed track adjuster cavity
- Standard track outside dozer frame, 2180-mm (86 in.) track gauge
- Extreme-service shoes, 610 mm (24 in.)
- ▲ Extreme-service shoes, 660 mm (26 in.)
- ▲ Extreme-service shoes, 711 mm (28 in.)
- ▲ Extreme-service shoes, trapezoidal, 610 mm (24 in.)
- ▲ Extreme-service shoes, trapezoidal, 660 mm (26 in.)
- ▲ Extreme-service shoes, trapezoidal, 711 mm (28 in.)
- ▲ Trash guard, final drive

Operator's Station

- Enclosed cab with air conditioner/heater
- Retractable seat belt, 76 mm (3 in.) (conforms to SAE J386)
- Air-suspension cloth seat
- ▲ Air-suspension heated deluxe seat
- AM/FM radio
- ▲ XM Satellite Radio™
- ▲ HVAC-powered precleaner
- Tilting cab
- 178-mm (7 in.) color, multi-language Primary Display Unit (PDU)
- Backup alarm
- 12-volt accessory plug
- Keyless start

1050K Overall Vehicle

- Environmental drain package
- Fluid-sample valves
- JDLink™ Ultimate wireless machine communication system (available in specific countries; see your local dealer for details)
- ▲ Quick service ports (HST, hydraulic, and engine oil, and coolant)
- ▲ Fast-fuel system
- Halogen lights (6 total): cylinder mounted (2); rear cab mounted (2); and roof mounted, front facing (2)
- Reflectors, rear facing (2)
- ▲ LED work lights (6)
- ▲ Deluxe LED work lights (10)
- ▲ Beacon light
- Grade-control-ready EH hydraulics
- ▲ Topcon-ready interface package
- ▲ Trimble-ready interface package
- ▲ Leica-ready interface package

Attachments

- ▲ Less blade
- ▲ U Blade, 3964 mm (156 in.)
- ▲ Semi-U Blade, 3964 mm (156 in.)
- ▲ U Blade, 3964 mm (156 in.), with rock rack and wear plate
- ▲ Semi-U Blade, 3964 mm (156 in.), with rock rack and wear plate
- ▲ Semi-U Blade, 3964 mm (156 in.), with push plate
- Standard end bits and cutting edges
- ▲ Heavy-duty end bits and cutting edges
- ▲ Cast end bits and cutting edges
- ▲ Ripper, multi-shank
- ▲ Ripper, single shank
- ▲ Ripper, single shank with hydraulic pin puller
- ▲ Rear counterweight, 2232 kg (4,921 lb.)
- ▲ Retrieval hitch



Net engine power is with standard equipment including air cleaner, exhaust system, alternator, and cooling fan at test conditions specified per ISO9249. No derating is required up to 3050-m (10,000 ft.) altitude. Specifications and design subject to change without notice. Wherever applicable, specifications are in accordance with SAE standards. Except where otherwise noted, these specifications are based on a unit with standard equipment, modular ROPS/cab, full fuel tank, and 79-kg (175 lb.) operator.