

# 310 P

## Backhoe Loader



JOHN DEERE





## *READY TO RUN IN THE REAL WORLD*

When owners and operators just like you — the people who know what customers need for their operations to succeed — weighed in on our latest backhoe loaders, we heeded the real-world feedback. You asked for one machine that capably completes the work of two. A powerful overachiever with outstanding loader performance, backhoe capability, and multifunction versatility. And packed with productivity-elevating options to match the application. Meet the 310 P-Tier Backhoe Loader, a standout multitasker ready to run — and get more done — in any corner of the working world.





## FEATURES

### **Powerful engine technology**

Rugged EPA Final Tier 4 (FT4)/EU Stage IV John Deere PowerTech EWL engine boosts power, torque, and reliability compared to previous models. Simple two-valve cylinder-head, wet-sleeve design with replaceable cylinder liners provides uniform cooling and aids in reducing oil breakdown and ring wear. Filters have been redesigned and relocated for easier servicing over earlier models.

### **Always on the move**

Optional limited-slip mechanical-front-wheel drive (MFWD) delivers sure-footed traction in any ground condition. Engage momentary MFWD “on the fly” with a touch of a button on the loader control (included with optional third-function auxiliary loader hydraulics).

### **Make the shift**

PowerShift™ transmission and machine forward/neutral/reverse (F-N-R) are controlled by an easy-to-use twist-grip Transmission Control Lever (TCL). Hydraulically actuated clutch packs enable smooth shifting and reliable performance under all operating conditions and loads.

### **Keeping it cool**

Field-proven open-center control valve and pump combination delivers high contamination resistance, exceptional swing control and multifunction performance, steady pressure/force control, and reliable operator “feel” compared to other hydraulic systems. Continuous oil flow boosts cooling and filtration, even with all functions in neutral. Cleaner, cooler oil improves system life and promotes uptime.



**POWERTECH™ EWL ENGINE**  
FEATURES RELOCATED FILTERS  
FOR EASY SERVICE ACCESS



### Save fuel with economy mode

Standard economy mode can be configured separately between loader and backhoe functions. Activate economy mode for backhoe functions while retaining full power for loader functions. This helps maximize fuel usage in lighter-work applications with minimal effect on machine performance.

### It all looks good from here

Spacious operator station is loaded with creature comforts including an efficient HVAC system, choice of adjustable mechanical or air-suspension seat, and optional premium radio with Bluetooth® and auxiliary input. Sightlines to the loader bucket corners over the sloped hood are clear.

### Take it easy

Enhanced “palm-on-top” loader-control grip is intuitive and easy to use. Redesigned loader-lever linkage reduces resistance and improves its throw and feel, decreasing lever travel by up to 15 percent.

### Enjoy the ride

Optional ride control reduces tire flexing over rough terrain at high speeds with a loaded bucket, reducing material spillage and improving machine ride to boost operator comfort and efficiency.

### Hit the ground running

Same-side ground-level service points speed daily checks and fills. Other commonsense features such as quick-change filters, extended service intervals, simple-to-read sight gauges, and easy-access grease zerks help increase uptime.



**ACTIVATE ECONOMY MODE  
FOR BACKHOE FUNCTIONS  
WHILE STILL POWERING  
LOADER FUNCTIONS**





## 310 P-TIER BACKHOE LOADER



### Precision Construction

From grade management and obstacle detection to product automation features and jobsite intelligence, this suite of construction technology delivers productivity solutions to help you get more done, more efficiently.

John Deere construction equipment comes with in-base connectivity – free from subscriptions or annual renewals. Analyze critical machine data, track utilization, review diagnostic alerts, and more from **the John Deere Operations Center™**. The Operations Center also enables **John Deere Connected Support™**, which uses data from thousands of connected machines to proactively address issues before they arise. Your dealer can also remotely monitor machine health, diagnose problems, and even update machine software without a trip to the jobsite.\*

\*Availability varies by region and product. Options not available in every country.





While general information, pictures, and descriptions are provided, some illustrations and text may include product options and accessories NOT AVAILABLE in all regions, and in some countries products and accessories may require modifications or additions to ensure compliance with the local regulations of those countries.

Engine		310 P-TIER			
Manufacturer and Model	John Deere PowerTech™ EWL 4.5L turbocharged		John Deere PowerTech™ 4.5L turbocharged		
Non-Road Emission Standard	EPA Final Tier 4/EU Stage IV		EPA Tier 2/EU Stage II		
Displacement	4.5 L (276 cu. in.)		4.5 L (276 cu. in.)		
Gross Peak Power	76 kW (102 hp) at 1,600 rpm		64 kW (85 hp) at 2,010 rpm		
Net Peak Power (ISO 9249)	75 kW (100 hp) at 1,600 rpm		62 kW (84 hp) at 2,000 rpm		
Net Peak Torque (ISO 9249)	459 Nm (338 lb.-ft.) at 1,500 rpm		347 Nm (256 lb.-ft.) at 1,400 rpm		
Net Torque Rise	51%		30%		
Lubrication	Pressure system with spin-on filter and cooler		Pressure system with spin-on filter and cooler		
Air Cleaner	Dual-stage dry type with safety element and evacuator valve		Dual-stage dry type with safety element and evacuator valve		
Cooling					
Fan Type	Electronically controlled, variable-rate, suction-type cooling fan standard		Viscous variable-rate (temperature controlled) cooling fan standard		
Engine Coolant Rating	-40 deg. C (-40 deg. F)		-40 deg. C (-40 deg. F)		
Engine Oil Cooler	Oil to water		Oil to water		
Powertrain					
Transmission	4-speed, helical-cut gears, full PowerShift™ transmission with hydraulic reverser standard; electric clutch cutoff on loader lever				
Torque Converter	Single stage, dual phase with 2.63:1 stall ratio, 280 mm (11.0 in.)				
PowerShift Standard Transmission					
Maximum Travel Speeds With Standard Engine,					
With 19.5L-24 Rear Tires	<i>Forward</i>	<i>Reverse</i>	<i>Forward</i>	<i>Reverse</i>	
Gear 1	5.4 km/h (3.4 mph)	6.8 km/h (4.2 mph)	5.4 km/h (3.4 mph)	6.8 km/h (4.2 mph)	
Gear 2	9.9 km/h (6.2 mph)	12.5 km/h (7.8 mph)	9.9 km/h (6.2 mph)	12.5 km/h (7.8 mph)	
Gear 3	20.3 km/h (12.6 mph)	—	20.3 km/h (12.6 mph)	—	
Gear 4	36.6 km/h (22.7 mph)	—	36.9 km/h (22.9 mph)	—	
Axles					
Axle Oscillation, Stop to Stop, Front Axle	22 deg.		22 deg.		
Axle Ratings	<i>Front</i>	<i>Rear</i>	<i>Front</i>	<i>Rear</i>	
SAE J43	5000 kg (11,000 lb.)	6000 kg (13,200 lb.)	5000 kg (11,000 lb.)	6000 kg (13,200 lb.)	
Dynamic	9000 kg (19,800 lb.)	10 000 kg (22,000 lb.)	9000 kg (19,800 lb.)	10 000 kg (22,000 lb.)	
Static	24 500 kg (54,000 lb.)	26 500 kg (58,400 lb.)	24 500 kg (54,000 lb.)	26 500 kg (58,400 lb.)	
Ultimate	41 500 kg (91,500 lb.)	41 500 kg (91,500 lb.)	41 500 kg (91,500 lb.)	41 500 kg (91,500 lb.)	
Differentials					
Mechanical-Front-Wheel-Drive (MFWD) Axle	Open – standard; automatic, limited-slip traction control – custom or optional				
Rear Axle	Foot actuated, hydraulically engaged 100% mechanical lock				
Steering (ISO 5010)					
Axle	<i>MFWD</i>	<i>Non-Powered Front</i>			
Curb-Turning Radius					
With Brakes	3.45 m (11 ft. 4 in.)		3.43 m (11 ft. 3 in.)		
Without Brakes	3.96 m (13 ft. 0 in.)		3.90 m (12 ft. 10 in.)		
Bucket-Clearance Circle					
With Brakes	9.86 m (32 ft. 4 in.)		9.80 m (32 ft. 2 in.)		
Without Brakes	10.61 m (34 ft. 10 in.)		10.48 m (34 ft. 5 in.)		
Steering Wheel Turns (lock to lock)	2.7		3.2		
MFWD and Rear Axle		Heavy duty, outboard planetary final drives distribute shock loads over 3 gears			
Brakes (ISO 3450)					
Service	Power assisted, hydraulic wet disc, mounted inboard, self-adjusting and self-equalizing				
Parking	Spring applied, hydraulically released, wet, multi-disc, independent of service brakes with electric switch control				
Hydraulics					
Main Pump	Open-center system; single-gear pump				
Pump Flow at 2,200 rpm					
Backhoe	106 L/m (28 gpm)				
Loader	106 L/m (28 gpm)				
System Relief Pressure					
Backhoe	24 993 kPa (3,625 psi)				
Loader	22 063 kPa (3,200 psi)				

## 310 P-TIER BACKHOE LOADER SPECIFICATIONS

# 310

# P

While general information, pictures, and descriptions are provided, some illustrations and text may include product options and accessories NOT AVAILABLE in all regions, and in some countries products and accessories may require modifications or additions to ensure compliance with the local regulations of those countries.

Hydraulics <i>(continued)</i>		310 P-TIER	
<b>Controls</b>			
Backhoe	2-lever mechanical standard; pilot controls with pattern select and manual and/or electric auxiliary functions optional		
Loader	Single-lever control with electric clutch cutoff switch standard; single-lever control with electric clutch cutoff switch, electrohydraulic (EH) proportional auxiliary roller, MFWD (momentary), and transmission quick-shift optional		
<b>Cylinders</b>			
Heat-treated, chrome-plated, polished rods; hardened steel (replaceable bushings) pivot pins			
	<i>Bore</i>	<i>Rod Diameter</i>	<i>Stroke</i>
Loader Boom (2)	80 mm (3.15 in.)	50 mm (1.97 in.)	790 mm (31.10 in.)
Loader Bucket (1)	90 mm (3.54 in.)	50 mm (1.97 in.)	744 mm (29.29 in.)
Backhoe Boom (1)	110 mm (4.33 in.)	56 mm (2.20 in.)	821 mm (32.32 in.)
Backhoe Crowd (1)	110 mm (4.33 in.)	63 mm (2.48 in.)	553 mm (21.77 in.)
Backhoe Bucket (1)	80 mm (3.15 in.)	50 mm (1.97 in.)	892 mm (35.12 in.)
Backhoe Swing (2)	80 mm (3.15 in.)	45 mm (1.77 in.)	310 mm (12.20 in.)
Backhoe Extendable Dipperstick (1)	63 mm (2.48 in.)	32 mm (1.26 in.)	1062 mm (41.81 in.)
Backhoe Stabilizer, Standard (2)	80 mm (3.15 in.)	50 mm (1.97 in.)	500 mm (19.69 in.)
Non-Powered Axle (1)	70 mm (2.76 in.)	42 mm (1.65 in.)	210 mm (8.27 in.)
MFWD (1)	65 mm (2.56 in.)	40 mm (1.57 in.)	210 mm (8.27 in.)
<b>Electrical</b>			
	<i>EPA Final Tier 4/EU Stage IV</i>		<i>EPA Tier 2/EU Stage II</i>
Voltage	12 volt		12 volt
Alternator Rating	145 amp		130 amp
Lights	10 halogen: 4 front, 4 rear, and 2 side docking (32,500 candlepower each); turn signals and flashers: 2 front and 2 rear; stop- and taillights; and 2 rear reflectors; factory-installed option for 2 LED spotlights and 8 LED floodlights in lieu of standard halogen light package		
<b>Operator Station</b>			
Type (ISO 3471)	Canopy, isolation mounted, ROPS/FOPS, left/right access, with molded roof; optional quarter cab (front glass only) and fully enclosed cab		
<b>Tires/Wheels</b>			
	<i>Front</i>	<i>Rear</i>	
Non-Powered Front Axle	12.5/80-18 F3 (12)	19.5L-24 R4 (12)	
	14.5/75-16.1 F3 (16)	19.5L-24 R4 (12)	
With MFWD	12-16.5 NHS (12)	19.5L-24 R4 (12)	
	12.5/80-18 I3 (12)	19.5L-24 R4 (10)	
	12.5/80-18 R4 (10)	19.5L-24 R4 (12)	
	12.5/80-18 I3 (12)	21L-24 R4 (12)	
	12.5/80-18 R4 (10)	21L-24 R4 (12)	
	340/80R18 XMCL	500/70R24 XMCL	
	340/80R18 550	500/70R24 550	
	340/80R18 580	500/70R24 580	
<b>Serviceability</b>			
<b>Refill Capacities</b>		<b>Refill Capacities <i>(continued)</i></b>	
Cooling System		Diesel Exhaust Fluid (DEF) Tank	13.7 L (3.6 gal.)
Cab	27.5 L (29.1 qt.)	(EPA Final Tier 4/EU Stage IV only)	
Canopy	25.7 L (27.2 qt.)	Hydraulic System	126.8 L (33.5 gal.)
Rear Axle	18.0 L (19.0 qt.)	Hydraulic Reservoir	45.0 L (11.9 gal.)
Engine Oil (including vertical spin-on filter)	13.0 L (13.7 qt.)	MFWD Axle	
Torque Converter and Transmission	15.1 L (16.0 qt.)	Differential Housing	6.5 L (6.9 qt.)
Fuel Tank (with ground-level fueling)	128.7 L (34.0 gal.)	Planetary (each)	0.9 L (1.0 qt.)
<b>Operating Weights</b>			
	<i>EPA Final Tier 4/EU Stage IV</i>		<i>EPA Tier 2/EU Stage II</i>
With Full Fuel Tank, 75-kg (165 lb.) Operator, Standard Equipment, Canopy, and Bumper	6904 kg (15,221 lb.)		6858 kg (14,982 lb.)
Typical With Cab, Extendable Dipperstick, and 204-kg (450 lb.) Counterweight	7581 kg (16,713 lb.)		7535 kg (16,612 lb.)
<b>Optional Components (weight difference between base equipment and option)</b>			
Cab	276 kg (608 lb.)	276 kg (608 lb.)	
MFWD With Tires	136 kg (300 lb.)	136 kg (300 lb.)	
Extendable Dipperstick	197 kg (434 lb.)	197 kg (434 lb.)	
Front Loader Coupler	146 kg (322 lb.)	146 kg (322 lb.)	
Backhoe Bucket Coupler	75 kg (165 lb.)	75 kg (165 lb.)	



# 310 P-TIER

While general information, pictures, and descriptions are provided, some illustrations and text may include product options and accessories NOT AVAILABLE in all regions, and in some countries products and accessories may require modifications or additions to ensure compliance with the local regulations of those countries.

Overall Dimensions		310 P-TIER
A	Ground Clearance, Minimum	293 mm (12 in.)
B	Overall Length, Transport	7.24 m (23 ft. 9 in.)
C	Width Over Tires	2.20 m (7 ft. 3 in.)
D	Height to Top of ROPS/Cab	2.81 m (9 ft. 3 in.)
E	Length From Axle to Axle	
	Non-Powered Front Axle	2.16 m (7 ft. 1 in.)
	MFWD Axle	2.19 m (7 ft. 2 in.)

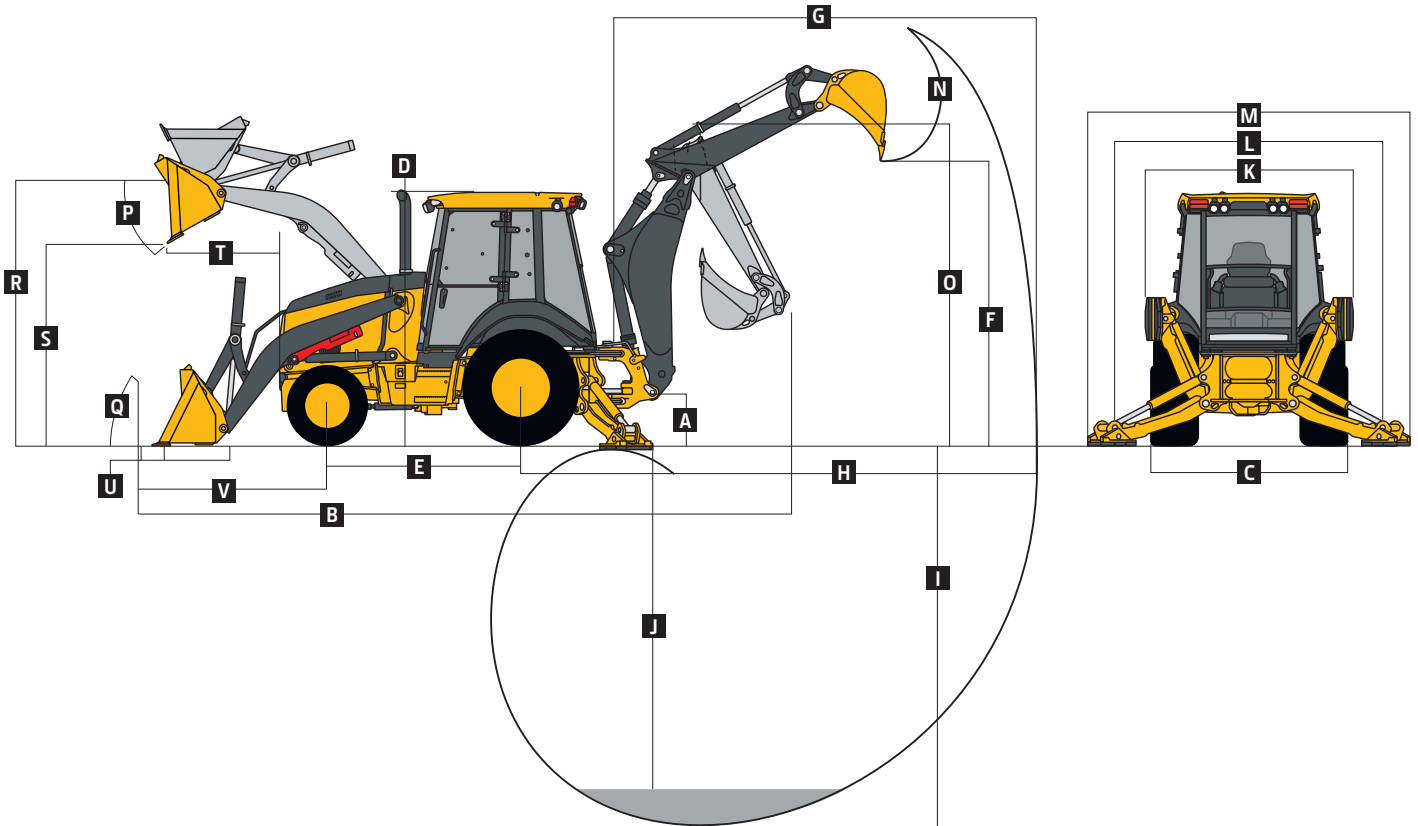

## Backhoe Dimensions and Performance

Backhoe specifications are with 610-mm x 0.18-m<sup>3</sup> (24 in. x 6.5 cu. ft.) bucket; dipper lift specs are with a boom angle of 65 deg.

Bucket Range	305–610 mm (12–24 in.)		
Digging Force			
Bucket Cylinder	48.2 kN (10,844 lb.)		
Crowd Cylinder	31.1 kN (6,992 lb.)		
Swing Arc	180 deg.		
Operator Control	2 levers		

	With Standard Backhoe	With Optional Extendable Dipperstick	
		Retracted	Extended
F Loading Height, Truck Loading Position	3.38 m (11 ft. 1 in.)	3.46 m (11 ft. 4 in.)	4.12 m (13 ft. 6 in.)
G Reach From Center of Swing Pivot	5.42 m (17 ft. 9 in.)	5.49 m (18 ft. 0 in.)	6.51 m (21 ft. 4 in.)
H Reach From Center of Rear Axle	6.49 m (21 ft. 3 in.)	6.55 m (21 ft. 6 in.)	7.57 m (24 ft. 10 in.)
I Digging Depth (SAE maximum)	4.30 m (14 ft. 1 in.)	4.38 m (14 ft. 4 in.)	5.43 m (17 ft. 10 in.)
J Digging Depth (SAE)			
610-mm (2 ft.) Flat Bottom	4.27 m (14 ft. 0 in.)	4.34 m (14 ft. 3 in.)	5.40 m (17 ft. 9 in.)
2440-mm (8 ft.) Flat Bottom	3.93 m (12 ft. 11 in.)	4.01 m (13 ft. 2 in.)	5.15 m (16 ft. 11 in.)
K Stabilizer Width, Transport	2.18 m (7 ft. 2 in.)	2.18 m (7 ft. 2 in.)	2.18 m (7 ft. 2 in.)
L Stabilizer Spread, Operating	3.10 m (10 ft. 2 in.)	3.10 m (10 ft. 2 in.)	3.10 m (10 ft. 2 in.)
M Stabilizer Overall Width, Operating	3.53 m (11 ft. 7 in.)	3.53 m (11 ft. 7 in.)	3.53 m (11 ft. 7 in.)
N Bucket Rotation	190 deg.	190 deg.	190 deg.
O Transport Height	3.39 m (11 ft. 1 in.)	3.39 m (11 ft. 1 in.)	3.39 m (11 ft. 1 in.)

## Loader Dimensions and Performance

P Bucket Dump Angle, Maximum	45 deg.
Q Rollback Angle at Ground Level	40 deg.



While general information, pictures, and descriptions are provided, some illustrations and text may include product options and accessories NOT AVAILABLE in all regions, and in some countries products and accessories may require modifications or additions to ensure compliance with the local regulations of those countries.

# 310 P-TIER

## Loader Dimensions and Performance (continued) 310 P-TIER

	Heavy-duty	Heavy-duty	Heavy-duty long lip	Multipurpose
Bucket Capacity	0.77 m <sup>3</sup> (1.00 cu. yd.)	0.86 m <sup>3</sup> (1.12 cu. yd.)	0.96 m <sup>3</sup> (1.25 cu. yd.)	0.96 m <sup>3</sup> (1.25 cu. yd.)
Width	2184 mm (86 in.)	2184 mm (86 in.)	2184 mm (86 in.)	2184 mm (86 in.)
Weight	363 kg (800 lb.)	390 kg (860 lb.)	405 kg (892 lb.)	794 kg (1,750 lb.)
Breakout Force	41.6 kN (9,361 lb.)	42.3 kN (9,512 lb.)	40.0 kN (8,983 lb.)	37.0 kN (8,321 lb.)
Lift Capacity, Full Height	2919 kg (6,435 lb.)	2995 kg (6,602 lb.)	2760 kg (6,085 lb.)	2427 kg (5,352 lb.)
R Height to Bucket Hinge Pin, Maximum	3.48 m (11 ft. 5 in.)	3.48 m (11 ft. 5 in.)	3.48 m (11 ft. 5 in.)	3.48 m (11 ft. 5 in.)
S Dump Clearance, Bucket at 45 deg.	2.74 m (9 ft. 0 in.)	2.78 m (9 ft. 1 in.)	2.68 m (8 ft. 9 in.)	2.68 m (8 ft. 9 in.)
T Reach at Full Height, Bucket at 45 deg.	702 mm (277 in.)	667 mm (26.3 in.)	793 mm (31.2 in.)	705 mm (27.8 in.)
U Digging Depth Below Ground, Bucket Level	70 mm (2.8 in.)	71 mm (2.8 in.)	51 mm (2.0 in.)	111 mm (4.4 in.)
V Length From Front Axle Centerline to Bucket Cutting Edge	2.02 m (6 ft. 8 in.)	1.97 m (6 ft. 6 in.)	2.12 m (6 ft. 11 in.)	2.10 m (6 ft. 11 in.)

## Lift Capacity With Quick-Coupler Forks (see line art below)

Hydraulic Capacity	1219-mm (48 in.) Tines	1524-mm (60 in.) Tines
A <sup>1</sup> Maximum Height	1711 kg (3,772 lb.)	1592 kg (3,510 lb.)
B <sup>1</sup> Maximum Reach	2690 kg (5,931 lb.)	2530 kg (5,578 lb.)
C <sup>1</sup> At Ground Line	3393 kg (7,480 lb.)	3203 kg (7,061 lb.)
D <sup>1</sup> Below Ground Line	185 mm (7.3 in.)	185 mm (7.3 in.)

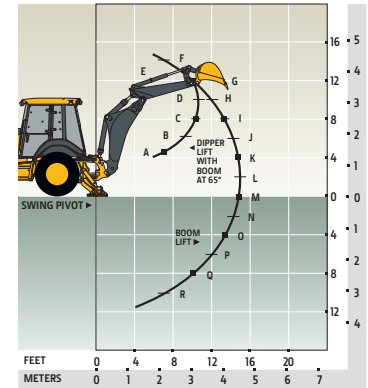
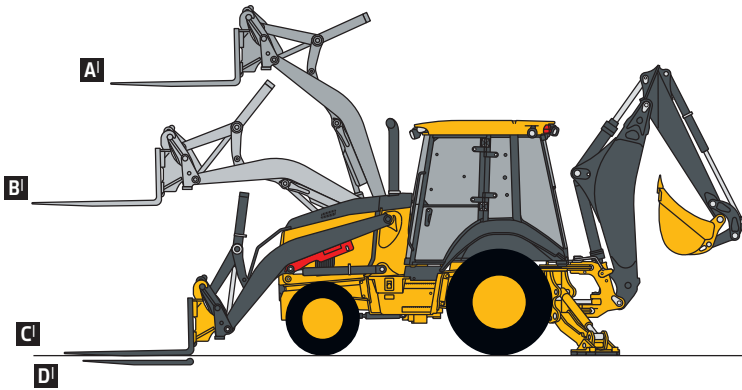

With Standard Dipperstick

## Lift Capacities (see line art at right)

Lift capacities are over-end values in kg (lb.). Figures listed are 100% of the maximum lift force available.

	With 1.06-m (3 ft. 6 in.) Extendable Dipperstick, Retracted	With 1.06-m (3 ft. 6 in.) Extendable Dipperstick, Extended
<i>With Standard Dipperstick</i>		
A	3593 kg (7,921 lb.)	3180 kg (7,011 lb.)
B	2686 kg (5,922 lb.)	2090 kg (4,607 lb.)
C	2363 kg (5,210 lb.)	1696 kg (3,740 lb.)
D	2319 kg (5,114 lb.)	1533 kg (3,380 lb.)
E	2117 kg (4,666 lb.)	1465 kg (3,229 lb.)
F	1680 kg (3,704 lb.)	1488 kg (3,280 lb.)
G	1657 kg (3,653 lb.)	1469 kg (3,239 lb.)
H	1593 kg (3,513 lb.)	1412 kg (3,112 lb.)
I	1526 kg (3,365 lb.)	1349 kg (2,975 lb.)
J	1462 kg (3,223 lb.)	1289 kg (2,841 lb.)
K	1402 kg (3,091 lb.)	1232 kg (2,716 lb.)
L	1347 kg (2,970 lb.)	1179 kg (2,600 lb.)
M	1297 kg (2,859 lb.)	1131 kg (2,493 lb.)
N	1251 kg (2,758 lb.)	1086 kg (2,395 lb.)
O	1209 kg (2,666 lb.)	1046 kg (2,306 lb.)
P	1172 kg (2,584 lb.)	1010 kg (2,226 lb.)
Q	1142 kg (2,517 lb.)	979 kg (2,159 lb.)
R	1130 kg (2,492 lb.)	965 kg (2,128 lb.)
S	—	906 kg (1,997 lb.)
T	—	888 kg (1,958 lb.)
U	—	873 kg (1,925 lb.)
V	—	863 kg (1,903 lb.)
W	—	861 kg (1,899 lb.)
X	—	879 kg (1,937 lb.)
Y	—	997 kg (2,198 lb.)

Lift capacities are over end with stabilizers down and tires tangent to ground.

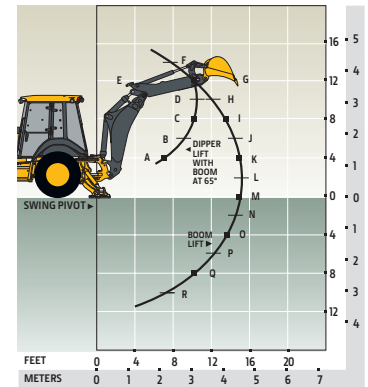

With Extendable Dipperstick, Retracted

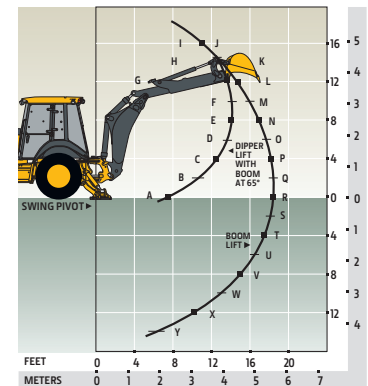

With Extendable Dipperstick, Extended



# Additional equipment

Key: ● Standard ▲ Optional or special

See your John Deere dealer for further information.

## 310 P Engine

- Coolant recovery tank with low-level indicator
- Foldout, hinged cooling system
- Serpentine belt with automatic belt tensioner
- Electronically controlled, variable-rate suction-type cooling fan
- Self-cleaning exhaust aftertreatment system
- ▲ Chrome exhaust extension
- Grid heat
- ▲ 1,000-watt electric engine coolant heater
- Electronic fuel lift pump

## Powertrain

- PowerShift™ transmission: Torque converter with twist-grip Transmission Control Lever (TCL) and neutral safety switch interlock (1st through 4th gears)
- Transmission oil cooler
- ▲ Transmission remote oil-sampling port
- Differential lock, electric foot actuated, protection on/off (software enabled)
- Planetary final drives
- Power-assisted hydraulic service brakes (conform to ISO 3450): Inboard, wet multi-disc, self-adjusting and self-equalizing
- Parking/emergency brake with electric switch control (conforms to ISO 3450): Spring applied, hydraulically released wet multi-disc / Independent of service brakes

## 310 P Powertrain (continued)

- Hydrostatic power steering with emergency manual mode
- ▲ Non-powered front axle
- Mechanical-front-wheel drive (MFWD) with open differential: Electric on/off control / Sealed axle
- ▲ MFWD with traction-control limited-slip differential: Electric on/off control / Sealed axle
- Automatic MFWD braking
- ▲ MFWD driveshaft guard

## Backhoe

- Standard dipperstick digging depth
- 4.30 m (14 ft. 1 in.)
- Extendable dipperstick extension
- ▲ 1.06 m (3 ft. 6 in.)
- ISO (Deere) 2-lever mechanical backhoe controls
- ▲ 2-lever pilot controls with pattern-selection feature
- Backhoe transport lock lever
- Swing lock pin stored in operator's station
- Stabilizers with 2-direction anti-drift valves
- ▲ Backhoe couplers for John Deere, Case, and Cat buckets
- ▲ Auxiliary backhoe valve with 1-way flow for hammers and compactors with plumbing
- ▲ Auxiliary backhoe valve with 1- and 2-way flow for swingers, thumbs, augers, etc. (plumbing not included)
- ▲ Hydraulic thumb

## 310 P Loader†

- Loader bucket anti-spill (rollback)
- Return-to-dig feature
- Single-lever control with electric clutch disconnect
- Bucket-level indicator
- Loader boom service lock
- ▲ Auxiliary loader hydraulics with single control lever with EH auxiliary control (MFWD and clutch disconnect)
- ▲ Hydraulic coupler for buckets, forks, etc.
- ▲ Standard ride control

## Hydraulic System

- 106-L/m (28 gpm) single-gear pump, open-center system
- Economy mode
- Dedicated hydraulic reservoir

## Electrical System

- 12-volt system
- 145-amp alternator for EPA Final Tier 4 (FT4)/EU Stage IV, 130-amp alternator for EPA Tier 2/EU Stage II
- Single battery with 175-min. reserve capacity and 950 CCA
- ▲ Dual batteries with 350-min. reserve capacity and 1,900 CCA
- ▲ Remote jump posts and battery disconnect

## Lights

- Halogen lights (10), 32,500 candlepower each (4 front driving/working, 4 rear working, and 2 side docking)
- Turn signal/flashing (2 front and 2 rear)
- Rear stop and tail (2)
- ▲ LED light package

†See dealer for range of heavy-duty (HD), multipurpose, and coupler buckets and forks.

While general information, pictures, and descriptions are provided, some illustrations and text may include product options and accessories NOT AVAILABLE in all regions, and in some countries products and accessories may require modifications or additions to ensure compliance with the local regulations of those countries.

Net engine power is with standard equipment including air cleaner, exhaust system, alternator, and cooling fan at test conditions specified per ISO 9249. Specifications and design are subject to change without notice. Wherever applicable, specifications are in accordance with ISO standards. Except where otherwise noted, these specifications are based on a unit with 19.5L-24-in. 12PR (R4) tubeless rear and 12-16.5 NHS (12) front tires, and 0.86-m<sup>3</sup> (1.12 cu. yd.) loader bucket.



# Additional equipment *(continued)*

Key: ● Standard ▲ Optional or special

See your John Deere dealer for further information.

## 310 P Operator's Station

- Modular-design ROPS/FOPS (Level 2) canopy with molded roof (meets ISO 3449 and ISO 3471/SAE J1040): Isolation mounted
- Molded floor mats (with pilot controls only)
- 12-volt outlet
- Lockable right-side storage
- ▲ Lockable left-hand storage with cup holders
- ▲ Interior front-view mirror
- ▲ Outside rearview mirrors
- Rotary-dial hand throttle
- Suspended foot throttle
- Mechanical-suspension seat, cloth cover
- ▲ Air-suspension heated seat (with cab only)
- ▲ Air-suspension vinyl seat
- Key start switch with electric fuel shutoff
- Tilt steering, infinitely adjustable (with cab only)
- ▲ Tilt steering, infinitely adjustable (with canopy and quarter cab)
- ▲ Machine security (enabled through monitor)
- Digital display of engine hours, engine rpm, and system voltage

## 310 P Operator's Station *(continued)*

- Monitor system with audible and visual warnings: Engine air restriction / Low alternator voltage / Engine oil pressure / Hydraulic filter restriction / Parking brake on/off / Aftertreatment temperature / Transmission fluid temperature / Fuel / Hour meter / Machine diagnostic information via 4-push-button/LCD operator interface
- **Canopy:** Mechanical-suspension deluxe vinyl swivel seat with lumbar adjustment and armrests (fully adjustable)
- ▲ **Quarter Cab:** Mechanical-suspension deluxe vinyl swivel seat with lumbar adjustment and armrests (fully adjustable), front windshield, and windshield wiper (1 front)
- ▲ **Cab with Dual Doors and A/C:** Mechanical-suspension deluxe fabric swivel seat with lumbar adjustment / Headliner, dome light, left and right cab doors, tinted safety glass, windshield wipers (1 rear and 1 front), front windshield washer, fresh-air intake, and heater/defroster/pressurizer (11.7-kW [40,000 Btu/h] heater) / A/C (7.6-kW [26,000 Btu/h] output and CFC-free R134a refrigerant)
- ▲ AM/FM/weather-band (WB) radio (with cab only)

## 310 P Operator's Station *(continued)*

- ▲ Premium radio package (with cab only; includes additional 12-volt and USB outlets)
- ### Overall Vehicle
- 1-piece unitized construction mainframe
  - Vehicle tie-downs (2 front and 2 rear)
  - Remote grease bank for front axle
  - Front bumper cover
  - ▲ HD front bumper
  - ▲ Front counterweight – 204 kg (450 lb.), 340 kg (750 lb.), 454 kg (1,000 lb.), or 567 kg (1,250 lb.)
  - ▲ Rubber grille bumpers
  - Fuel tank, 128.7 L (34 gal.), ground-level fueling
  - 2-position easy-tilt hood
  - Extended grille frame
  - Toolbox with padlock hasp
  - Vandal protection for locking monitor, engine hood, toolbox, hydraulic reservoir, and fuel tank
  - Reverse warning alarm
  - Dent-resistant full-coverage rear fenders
  - ▲ Backhoe boom-protection plate
  - JDLink™ wireless communication system (available in specific countries; see your dealer for details)
  - ▲ HD front grille screen
  - ▲ HD stabilizer pads

While general information, pictures, and descriptions are provided, some illustrations and text may include product options and accessories NOT AVAILABLE in all regions, and in some countries products and accessories may require modifications or additions to ensure compliance with the local regulations of those countries.

Net engine power is with standard equipment including air cleaner, exhaust system, alternator, and cooling fan at test conditions specified per ISO 9249. Specifications and design are subject to change without notice. Wherever applicable, specifications are in accordance with ISO standards. Except where otherwise noted, these specifications are based on a unit with 19.5L-24-in. 12PR (R4) tubeless rear and 12-16.5 NHS (12) front tires, and 0.86-m<sup>3</sup> (1.12 cu. yd.) loader bucket.





  
MB310PAU (23-05)



**JOHN DEERE**