

# ARTICULATED DUMP TRUCKS



JOHN DEERE

410E-II / 460E-II



*BUILT FOR THE  
LONG HAUL*





*HARDWORKING,  
YET EASYGO*





PRODUCTIVE



EASY TO RUN



EFFICIENT

**ING.**





## ***SIMPLY MORE EFFICIENT.***

How did we improve on our E-Series Articulated Dump Trucks (ADTs)? We simplified. We took our powerful, productive, and popular ADTs and made them even more comfortable and easy to use. We added three new drive modes, including Eco mode that burns less fuel. We made them lighter and more fuel efficient while beefing up reliability with more robust sensors and simplified hydraulic and electrical routing. We improved operator comfort with new options such as our automatic temperature control (ATC) system and a premium heated/ventilated seat. And we made daily maintenance even easier with optional auto lube — all with the goal of enhancing our customers' overall experience, with machines that are simply better.



# EASY DOES IT

## BIG PRODUCTIVITY WITH LESS EFFORT.

The fuel-efficient, reliable 410E-II and 460E-II are designed with operator comfort and ease of use in mind.

### More bang from your truck

Eco mode automatically adjusts engine power and transmission settings based on load while limiting horsepower.

### Fuel efficient

E-II Series ADTs consume up to seven-percent less fuel than E-Series machines due to reduced weight and improved hydraulic efficiency. Weighing in at around 1,100-pounds less than the E-Series, E-II models boost fuel economy without sacrificing performance.

### Rugged and reliable

Hose and wire routing have been simplified to reduce rubbing and improve reliability. Factory-installed auto lube boosts uptime and reliability.

### Keep it simple

Operator-friendly features include three new drive modes and options such as automatic temperature control (ATC) system and premium heated/ventilated seat. With rotary switches, a sealed-switch module is no longer needed, easing operator use.



# 10% FEWER HOSE CONNECTIONS

*COMPARED TO E-SERIES*





STANDOUT FEATURE

The image shows the interior of a John Deere truck cab. The driver's seat is on the right, featuring a grey and black leather-like upholstery with a John Deere logo on the headrest. The steering wheel is on the left. The dashboard and center console are visible. Through the windshield, a quarry or construction site is visible, with large piles of material and a clear blue sky. A sign with the word "GREEN" is visible on the windshield.

***STAY PRODUCTIVE  
“HAUL”  
DAY LONG.***

# GET IN THE DRIVER'S SEAT

## TAKE COMMAND IN QUIET COMFORT.

Quiet, pressurized Deere-designed cab features a new, easy-to-read monitor and rear-camera display, along with options such as premium heated/ventilated seat and automatic temperature control (ATC) system.

### Buckle up

Three-inch seat belt comes standard. Or opt for a retractable four-point seat-belt harness with seat-belt indicator light.

### One step at a time

To ease entry and exit, stairway lights can be turned on by pushing a button from ground level. Push the button again to turn off the lights, or they will turn off automatically after a predetermined length of time. Handrails and steps help make for a surefooted start and end to your day.

### Set and forget

Optional ATC system allows operators to simply select a desired temperature to get comfortable. Rotary switches eliminate the need for a second sealed-switch module, making room for more storage.

### Keep tabs on your truck

Large, easy-to-navigate monitor provides intuitive, push-button access to a wealth of machine information, including temperatures, pressures, and diagnostics. Standard rear-camera display shows the action behind the machine.

### Make yourself comfortable

Creature comforts include ample storage for a lunch box and devices, USB and 12-volt power ports, keyless start, low-effort push-button controls, tilt/telescoping steering wheel, and optional premium radio with Bluetooth® capability.

### Have a seat

Standard high-back air-suspension seat adjusts multiple ways for daylong comfort and support. Or choose the optional premium heated/ventilated seat with heavy-duty air-suspension and adjustable seat pan for even more comfort. A trainer seat comes standard.



**ATC SYSTEM**  
OPTIONAL





# HAUL MORE FOR LESS

## MORE EFFICIENT BY DESIGN.

Featuring three new drive modes, E-II Series ADTs are even more efficient than E-Series machines. New wheel-speed sensors improve auto-differential lock response to help keep materials moving in slippery muck.

### Choose how you work

Three drive modes enable easy customization by both inexperienced and veteran operators for a variety of conditions: **Normal** mode for everyday operation; **Eco** mode that, when conditions allow, conserves fuel by managing engine power delivery as well as optimizing transmission response for those conditions; and **Traction** mode, which optimizes differential lock for maximum tractive effort in soft and slippery ground conditions.

### Improved diff-lock performance

New wheel-speed sensors provide a more accurate reading than ground-speed radar to confirm traction-boosting auto-differential lock engages when needed. Diff lock can also be engaged on the fly while slipping.

### Safety first

Whether you're working at a Mine Safety and Health Administration (MSHA)-regulated mining site or quarry, or running an aggregate operation, safety comes first and foremost. Features such as remote park-brake release, rollover protection, ground-level service, and auto horn help keep operators out of harm's way.

### Fuel-efficient fan with reversing option

Engine, hydraulic, transmission, and service-brake coolers employ a hydraulic-drive fan that runs only as fast or as often as necessary, helping conserve power and fuel. Reversible option back-blows cooler cores, reducing the frequency of manual cleanout.

### Extend your workday

Opt for the LED lighting package for increased illumination. LED drive lights deliver twice the lumen output of standard halogens and include additional work lights that are three times as bright as the optional halogens. This option provides a total of 11 LED lights.

### Wider, lower, better

Redesigned, wider dump body provides better tire coverage. Lower overall dump-body height allows it to be loaded with ease.

### Strong, lightweight dump body and chassis

High-alloy-steel dump body and chassis deliver outstanding strength and rigidity without adding weight.



**ECO MODE REDUCES FUEL CONSUMPTION BY UP TO 12% COMPARED TO NORMAL MODE**







***DRIVEN TO  
SUCCEED.***





# ***BORN READY.***

## ***DEERE DESIGNED AND BUILT MADE WITH PRIDE.***

E-II Series ADTs are designed and manufactured with state-of-the-art tools and techniques by a quality-conscious workforce in Dubuque and Davenport, Iowa.





### **Redesigned electrical and hydraulic systems**

Routing of the electrical and hydraulic systems has been significantly simplified to improve reliability. Reduction of hose length and number of connections — 10-percent fewer than E-Series models — considerably minimizes system complexity.

### **Designed for durability**

Heavy-duty, purpose-built John Deere axles are lubricated, filtered, and cooled for longer life than E-Series axles. Spring-applied, hydraulic-released park brake is extremely reliable.

### **Maximum brake life**

Inboard wet-disc brakes run cool, clean, and unexposed. Combined with the strong transmission retarder, they help deliver consistent stops and maximum brake life.

### **Rollover protection**

Operators can set limits for the rear-chassis level when unloading. If the limit is exceeded, the dump body will not raise and a message will appear on the monitor instructing the operator to reposition the truck.



---

# HIT THE GROUND RUNNING

*GROUND-LEVEL SERVICE, OPTIONAL AUTO LUBE,  
AND MACHINE MONITORING KEEP THINGS MOVING.*

## **Simple ground-level access**

All daily checks and service are done from ground level without needing to mount the machine and tie off, as required by the Mine Safety and Health Administration (MSHA).

## **Secure dump-body service**

Safety pin locks the dump body to the mainframe in a fully upright position and disengages hydraulics to prevent the body from being lowered.

## **Auto-lube option**

Factory-installed auto-lube option is electrically powered and integrated with machine diagnostics to help verify daily maintenance is being performed.





---

Get valuable insight with

## **JOHN DEERE WORKSIGHT™**

The John Deere WorkSight suite of construction technology delivers **Productivity Solutions** to help you get more done, more efficiently. The in-base, five-year JDLink™ telematics subscription provides machine location, utilization data, and alerts to help you maximize productivity and efficiency. Other productivity solutions include grade-management options for multiple machine forms and payload weighing for wheel loaders and articulated dump trucks.

To maximize uptime and lower costs, JDLink telematics also enables **John Deere Connected Support™**. John Deere's centralized Machine Health Monitoring Center analyzes data from thousands of connected machines, identifies trends, and develops recommended actions, called Expert Alerts, to help prevent downtime. Dealers use Expert Alerts to proactively address conditions that may otherwise likely lead to downtime. Your dealer can also monitor machine health and leverage remote diagnostics and programming capability to further diagnose problems and even update machine software without a time-consuming trip to the jobsite.







# 410E-II SPECIFICATIONS

<b>Engine</b>		<b>410E-II</b>	
Manufacturer and Model	John Deere PowerTech™ 6135		
Non-Roak Emission Standards	EPA Final Tier 4/EU Stage IV		
Configuration	Inline 6 with variable-geometry turbocharger (VGT) and exhaust gas recirculation (EGR)		
Valves per Cylinder	4		
Displacement	13.5 L (823.8 cu. in.)		
Net Peak Power (ISO 9249)	329 kW (441 hp) at 1,700 rpm		
Net Peak Torque (ISO 9249)	2414 Nm (1,780 lb.-ft.) at 1,200 rpm		
Aspiration	Twin turbocharged and charge-air cooled		
Fuel System	Mechanically actuated electronic unit injection, with 10- and 4-micron filtration and water separator		
Cold-Start Aid	Optional ether start, block heater, and diesel-fired coolant heater		
<b>Cooling</b>			
Engine Cooling	Coolant mixture air cooled with two single pass radiators and has a remote pressurized coolant tank; separate charge-air cooler used for air system		
<b>Powertrain</b>			
<b>Transmission</b>	8-speed forward, 4-speed reverse, countershaft/planetary type with integral retarder and torque-proportioning differential		
Manufacturer and Model	ZF ErgoPower™ L II 8EP420		
Retarder	Integral, gear dependent, hydrodynamic, oil-to-air cooled, variable, fully automatic		
Differential	Torque-proportioning, planetary-type, Inter-Axle Differential Lock (IDL) with PowerShift™ lockup clutch		
Output Torque Split	32% front / 68% rear		
Shift Controls	Fully automatic, electronically modulated PowerShift, load-speed adaptive with gear-skip and gear-hunting protection		
Operator Interface	Push-button F-N-R, selectable speed- and gear-range limits, selectable retarder aggressiveness, downhill-descent control, and gear-hold		
Speeds	<i>Forward</i>	<i>Reverse</i>	
Gear 1	6 km/h (4 mph)	6 km/h (4 mph)	
Gear 2	8 km/h (5 mph)	8 km/h (5 mph)	
Gear 3	11 km/h (7 mph)	11 km/h (7 mph)	
Gear 4	16 km/h (10 mph)	16 km/h (10 mph)	
Gear 5	23 km/h (14 mph)	—	
Gear 6	32 km/h (20 mph)	—	
Gear 7	45 km/h (28 mph)	—	
Gear 8	55 km/h (34 mph)	—	
<b>Axles</b>			
Differential	Helical transfer gears, spiral bevel, hydraulically actuated PowerShift Cross-Axle Differential Lock (CDL)		
Final Drive	Extreme-duty outboard-mounted planetary; cooled and filtered oil		
<b>Brake System</b>			
Service	Dual-circuit, hydraulically actuated, wet multi-disc, force cooled, inboard mounted		
Parking	Spring-applied hydraulically released, driveline-mounted, dry-disc with self-adjusting wear pad		
Auxiliary	Fully automatic; transmission mounted, gear dependent; hydrodynamic retarder with selectable levels		
<b>Hydraulics</b>			
Type	Closed-center, variable-displacement, load-sensing system		
Main Pump	Variable-displacement, axial piston		
Secondary Steering Pump	Ground-driven gear pump with hydraulic unloader valve		
Dump Cylinders	Dual-acting, single-stage with heat-treated, chrome-plated, and polished cylinder rods; hardened steel replaceable bushings and pivot pins		
<b>Cycle Time</b>			
Power Down	7 sec.		
Raise Time	12 sec.		

While general information, pictures, and descriptions are provided, some illustrations and text may include product options and accessories NOT AVAILABLE in all regions, and in some countries products and accessories may require modifications or additions to ensure compliance with the local regulations of those countries.



# 410E-II SPECIFICATIONS



<b>Electrical</b>	<b>410E-II</b>
Voltage	24 volt
Number of Batteries	2 x 12 volt
Battery Capacity	1,400-CCA batteries
Alternator Rating	28 volt / 145 amp
<b>Steering System</b>	
Type	2 hydrostatically actuated, double-acting hydraulic cylinders; ground-driven secondary steering pump
Angle	45 deg. side to side
Lock-to-Lock Turns	4.0
<b>Suspension</b>	
Front	Semi-independent leading A-frame geometry with transverse link for lateral restraint and self-leveling oil-filled struts with integrated nitrogen-charged accumulators
Rear	Load-equalizing, pivoting walking beams with laminated suspension blocks, tri-link geometry, and transverse links for lateral restraint
<b>Body</b>	
Type	High-strength steel dump body
<b>Capacity</b>	
Struck	17.1 m <sup>3</sup> (22.3 cu. yd.)
Heaped at 2:1 ISO 6483 Ratio	22.9 m <sup>3</sup> (30.0 cu. yd.)
With Optional Tailgate	24.2 m <sup>3</sup> (31.7 cu. yd.)
Maximum Dump Angle	70 deg.
Heater	Body ducted to accept optional exhaust heating
<b>Tires/Wheels</b>	
Type and Size	29.5R25 radial earthmovers standard / 875/65R29 optional
<b>Serviceability</b>	
<b>Ground-Level Service</b>	
Fluids and Filters	Ground-level checks of engine, transmission, and hydraulic oil levels; ground-level fuel and diesel exhaust fluid (DEF) refill; ground-level replacement of engine, transmission, axles, and fuel filters
Coolers	Swing-out coolers for easy cleaning standard; reversing fans optional
Fluid Sampling	Fluid-sampling ports standard; quick-service ports optional
<b>Refill Capacities</b>	
Fuel Tank	609 L (161.0 gal.)
Diesel Exhaust Fluid (DEF) Tank	48 L (13.0 gal.)
Engine Oil With Filter	43 L (11.4 gal.)
Engine Coolant	90 L (23.8 gal.)
Transmission Fluid	60 L (15.9 gal.)
Hydraulic Reservoir	176 L (46.5 gal.)
Axle Fluid With Filter	
Front	62 L (16.4 gal.)
Mid	62 L (16.4 gal.)
Rear	68 L (18.0 gal.)



## 410E-II (CONTINUED)

Operating Weights		410E-II	
With Standard Equipment		<i>Empty</i>	<i>Loaded</i>
Front	17 082 kg (37,659 lb.)		22 863 kg (50,404 lb.)
Middle	7159 kg (15,783 lb.)		22 902 kg (50,489 lb.)
Rear	7159 kg (15,783 lb.)		22 902 kg (50,489 lb.)
Total	31 400 kg (69,225 lb.)		68 666 kg (151,382 lb.)
Rated Payload	37 266 kg (82,157 lb.)		
Optional Components			
Dump-Body Liner, Steel	1388 kg (3,060 lb.)		
Tailgate	943 kg (2,079 lb.)		
875/65R29 Tires	1286 kg (2,835 lb.)		
Operating Dimensions			
Turning Circle Radius			
Inside	4.63 m (15 ft. 2 in.)		
Outside	8.90 m (29 ft. 2 in.)		
Machine Dimensions			
A	Width With Mirrors in Operating Position	3.84 m (12 ft. 7 in.)	
B	Length	10.64 m (34 ft. 11 in.)	
C	Height	3.86 m (12 ft. 8 in.)	
	Tires	29.5R25	875/65R29
D	Tread Width	2.66 m (8 ft. 9 in.)	2.70 m (8 ft. 10 in.)
E	Width Over Tires	3.41 m (11 ft. 2 in.)	3.58 m (11 ft. 9 in.)
F	Width Over Fenders	3.44 m (11 ft. 3 in.)	3.65 m (12 ft. 0 in.)
G	Ground Clearance	0.54 m (21 in.)	
H	Dump Body Height, Dump Position	7.09 m (23 ft. 3 in.)	
I	Dump Body Side Rail Height	3.15 m (10 ft. 4 in.)	
J	Dump Body Dump Lip Height, Transport Position	3.71 m (12 ft. 2 in.)	
K	Dump Body Ground Clearance, Dump Position	1.11 m (3 ft. 8 in.)	
L	Dump Body Length	5.81 m (19 ft. 1 in.)	
M	Rear Axle Centerline to Rear of Dump Body	1.21 m (4 ft. 0 in.)	
N	Mid Axle to Rear Axle Centerline	1.96 m (6 ft. 5 in.)	
O	Front Axle to Mid Axle Centerline	4.63 m (15 ft. 2 in.)	
P	Front Axle Centerline to Front of Machine	2.84 m (9 ft. 4 in.)	
Q	Approach Angle	26 deg.	
R	Maximum Dump Angle	70 deg.	
Shipping Dimensions			
	Overall Height (suspension lowered 75 mm [3 in.])	3.78 m (12 ft. 5 in.)	
	Overall Width		
	Dump Body	3.46 m (11 ft. 4 in.)	
	Tailgate Installed	3.59 m (11 ft. 9 in.)	

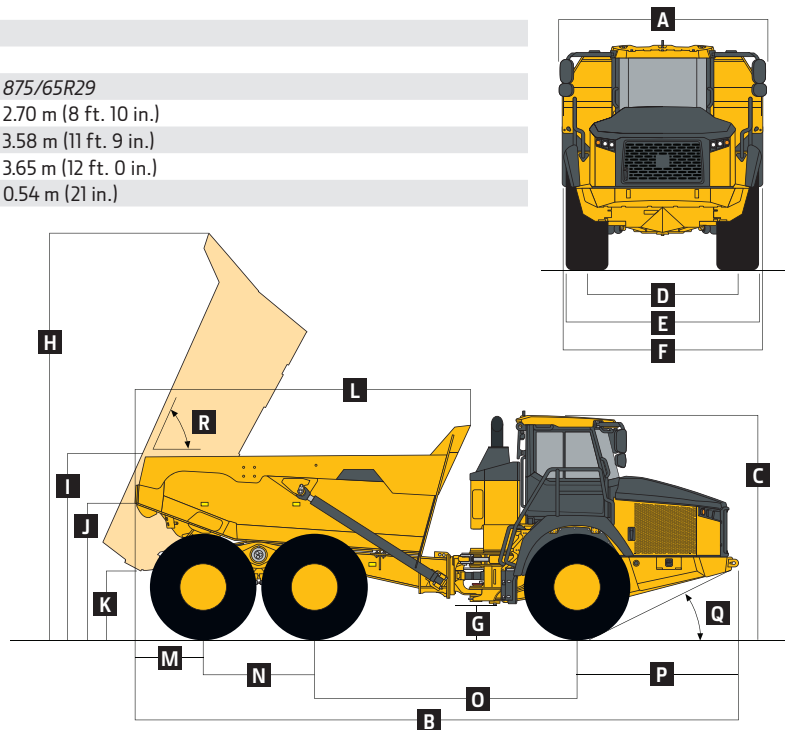

While general information, pictures, and descriptions are provided, some illustrations and text may include product options and accessories NOT AVAILABLE in all regions, and in some countries products and accessories may require modifications or additions to ensure compliance with the local regulations of those countries.



# 460E-II SPECIFICATIONS



<b>Engine</b>		<b>460E-II</b>	
Manufacturer and Model	John Deere PowerTech™ 6135		
Non-Road Emission Standards	EPA Final Tier 4/EU Stage IV		
Configuration	Inline 6 with variable-geometry turbocharger (VGT) and exhaust gas recirculation (EGR)		
Valves per Cylinder	4		
Displacement	13.5 L (823.8 cu. in.)		
Net Peak Power (ISO 9249)	359 kW (481 hp) at 1,700 rpm		
Net Peak Torque (ISO 9249)	2477 Nm (1,827 lb.-ft.) at 1,200 rpm		
Aspiration	Twin turbocharged and charge-air cooled		
Fuel System	Mechanically actuated electronic unit injection, with 10- and 4-micron filtration and water separator		
Cold-Start Aid	Optional ether start, block heater, and diesel-fired coolant heater		
<b>Cooling</b>			
Engine Cooling	Coolant mixture air cooled with two single pass radiators and has a remote pressurized coolant tank; separate charge-air cooler used for air system		
<b>Powertrain</b>			
<b>Transmission</b>	8-speed forward, 4-speed reverse, countershaft/planetary type with integral retarder and torque-proportioning differential		
Manufacturer and Model	ZF ErgoPower™ L II 8EP470		
Retarder	Integral, gear dependent, hydrodynamic, oil-to-air cooled, variable, fully automatic		
Differential	Torque-proportioning, planetary-type, Inter-Axle Differential Lock (IDL) with PowerShift™ lockup clutch		
Output Torque Split	32% front / 68% rear		
Shift Controls	Fully automatic, electronically modulated PowerShift, load-speed adaptive with gear-skip and gear-hunting protection		
Operator Interface	Push-button F-N-R, selectable speed- and gear-range limits, selectable retarder aggressiveness, downhill-descent control, and gear-hold		
Speeds	<i>Forward</i>	<i>Reverse</i>	
Gear 1	6 km/h (4 mph)	6 km/h (4 mph)	
Gear 2	8 km/h (5 mph)	8 km/h (5 mph)	
Gear 3	11 km/h (7 mph)	11 km/h (7 mph)	
Gear 4	16 km/h (10 mph)	16 km/h (10 mph)	
Gear 5	23 km/h (14 mph)	—	
Gear 6	32 km/h (20 mph)	—	
Gear 7	45 km/h (28 mph)	—	
Gear 8	55 km/h (34 mph)	—	
<b>Axles</b>			
Differential	Helical transfer gears, spiral bevel, hydraulically actuated PowerShift Cross-Axle Differential Lock (CDL)		
Final Drive	Extreme-duty outboard-mounted planetary; cooled and filtered oil		
<b>Brake System</b>			
Service	Dual-circuit, hydraulically actuated, wet multi-disc, force cooled, inboard mounted		
Parking	Spring-applied hydraulically released, driveline-mounted, dry-disc with self-adjusting wear pad		
Auxiliary	Fully automatic; transmission mounted, gear dependent; hydrodynamic retarder with selectable levels		
<b>Hydraulics</b>			
Type	Closed-center, variable-displacement, load-sensing system		
Main Pump	Variable-displacement, axial piston		
Secondary Steering Pump	Ground-driven gear pump with hydraulic unloader valve		
Dump Cylinders	Dual-acting, single-stage with heat-treated, chrome-plated, and polished cylinder rods; hardened steel replaceable bushings and pivot pins		
<b>Cycle Time</b>			
Power Down	7 sec.		
Raise Time	12 sec.		

While general information, pictures, and descriptions are provided, some illustrations and text may include product options and accessories NOT AVAILABLE in all regions, and in some countries products and accessories may require modifications or additions to ensure compliance with the local regulations of those countries.



## 460E-II (CONTINUED)

<b>Electrical</b>	<b>460E-II</b>
Voltage	24 volt
Number of Batteries	2 x 12 volt
Battery Capacity	1,400-CCA batteries
Alternator Rating	28 volt / 145 amp
<b>Steering System</b>	
Type	2 hydrostatically actuated, double-acting hydraulic cylinders; ground-driven secondary steering pump
Angle	45 deg. side to side
Lock-to-Lock Turns	4.0
<b>Suspension</b>	
Front	Semi-independent leading A-frame geometry with transverse link for lateral restraint and self-leveling oil-filled struts with integrated nitrogen-charged accumulators
Rear	Load-equalizing, pivoting walking beams with laminated suspension blocks, tri-link geometry, and transverse links for lateral restraint
<b>Body</b>	
Type	High-strength steel dump body
<b>Capacity</b>	
Struck	19.5 m <sup>3</sup> (25.5 cu. yd.)
Heaped at 2:1 ISO 6483 Ratio	25.2 m <sup>3</sup> (32.9 cu. yd.)
With Optional Tailgate	27.0 m <sup>3</sup> (35.4 cu. yd.)
Maximum Dump Angle	70 deg.
Heater	Body ducted to accept optional exhaust heating
<b>Tires/Wheels</b>	
Type and Size	29.5R25 radial earthmovers standard / 875/65R29 optional
<b>Serviceability</b>	
<b>Ground-Level Service</b>	
Fluids and Filters	Ground-level checks of engine, transmission, and hydraulic oil levels; ground-level fuel and diesel exhaust fluid (DEF) refill; ground-level replacement of engine, transmission, axles, and fuel filters
Coolers	Swing-out coolers for easy cleaning standard; reversing fans optional
Fluid Sampling	Fluid-sampling ports standard; quick-service ports optional
<b>Refill Capacities</b>	
Fuel Tank	609 L (161.0 gal.)
Diesel Exhaust Fluid (DEF) Tank	48 L (13.0 gal.)
Engine Oil With Filter	43 L (11.4 gal.)
Engine Coolant	90 L (23.8 gal.)
Transmission Fluid	60 L (15.9 gal.)
Hydraulic Reservoir	176 L (46.5 gal.)
Axle Fluid With Filter	
Front	62 L (16.4 gal.)
Mid	62 L (16.4 gal.)
Rear	68 L (18.0 gal.)

While general information, pictures, and descriptions are provided, some illustrations and text may include product options and accessories NOT AVAILABLE in all regions, and in some countries products and accessories may require modifications or additions to ensure compliance with the local regulations of those countries.



## 460E-II (CONTINUED)

Operating Weights		460E-II	
With Standard Equipment	<i>Empty</i>		<i>Loaded</i>
Front	17 090 kg (37,677 lb.)		23 880 kg (52,646 lb.)
Middle	7305 kg (16,105 lb.)		24 820 kg (54,719 lb.)
Rear	7305 kg (16,105 lb.)		24 820 kg (54,719 lb.)
Total	31 700 kg (69,886 lb.)		73 520 kg (162,084 lb.)
Rated Payload	41 820 kg (92,197 lb.)		
<b>Optional Components</b>			
Dump-Body Liner, Steel	1389 kg (3,062 lb.)		
Tailgate	986 kg (2,174 lb.)		
875/65R29 Tires	1286 kg (2,835 lb.)		
<b>Operating Dimensions</b>			
Turning Circle Radius			
Inside	4.63 m (15 ft. 2 in.)		
Outside	8.90 m (29 ft. 2 in.)		
<b>Machine Dimensions</b>			
A Width With Mirrors in Operating Position	3.84 m (12 ft. 7 in.)		
B Length	10.64 m (34 ft. 11 in.)		
C Height	3.89 m (12 ft. 9 in.)		
Tires	29.5R25	875/65R29	
D Tread Width	2.66 m (8 ft. 9 in.)	2.70 m (8 ft. 10 in.)	
E Width Over Tires	3.41 m (11 ft. 2 in.)	3.58 m (11 ft. 9 in.)	
F Width Over Fenders	3.44 m (11 ft. 3 in.)	3.65 m (12 ft. 0 in.)	
G Ground Clearance	0.54 m (21 in.)	0.54 m (21 in.)	
H Dump Body Height, Dump Position	7.18 m (23 ft. 7 in.)		
I Dump Body Side Rail Height	3.34 m (10 ft. 11 in.)		
J Dump Body Dump Lip Height, Transport Position	3.89 m (12 ft. 9 in.)		
K Dump Body Ground Clearance, Dump Position	1.12 m (3 ft. 8 in.)		
L Dump Body Length	5.86 m (19 ft. 3 in.)		
M Rear Axle Centerline to Rear of Dump Body	1.21 m (4 ft. 0 in.)		
N Mid Axle to Rear Axle Centerline	1.96 m (6 ft. 5 in.)		
O Front Axle to Mid Axle Centerline	4.63 m (15 ft. 2 in.)		
P Front Axle Centerline to Front of Machine	2.84 m (9 ft. 4 in.)		
Q Approach Angle	26 deg.		
R Maximum Dump Angle	70 deg.		
<b>Shipping Dimensions</b>			
Overall Height (suspension lowered)	3.81 m (12 ft. 6 in.)		
75 mm (3 in.)			
Overall Width			
Dump Body	3.46 m (11 ft. 4 in.)		
Tailgate Installed	3.53 m (11 ft. 7 in.)		

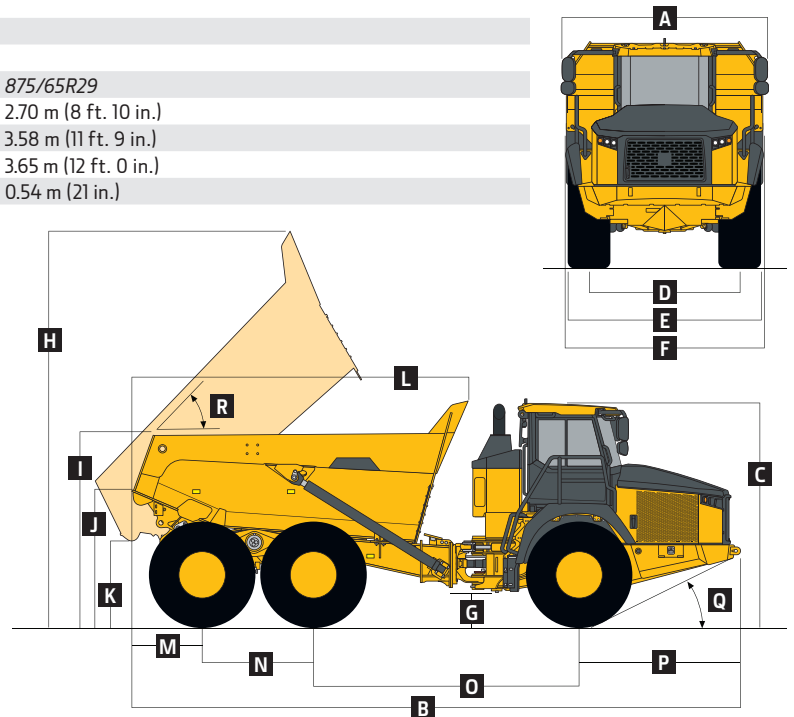

While general information, pictures, and descriptions are provided, some illustrations and text may include product options and accessories NOT AVAILABLE in all regions, and in some countries products and accessories may require modifications or additions to ensure compliance with the local regulations of those countries.



# Additional equipment

Key: ● Standard ▲ Optional or special

See your John Deere dealer for further information.

410E	460E	Engine
●	●	Meets EPA Final Tier 4/EU Stage IV emissions
●	●	John Deere PowerTech™ 6135 – 13.5L (824 cu. in.) inline 6
●	●	Wet-sleeve cylinder liners
●	●	Variable-geometry turbocharger (VGT)
●	●	External cooled exhaust gas recirculation (EGR)
●	●	Dual-element air cleaner
●	●	Precleaner
●	●	Fuel filters with water separator and automatic electronic priming
●	●	Ground-level fueling and diesel exhaust fluid (DEF) fill
●	●	In-line DEF filter
▲	▲	Fast-fill fuel system
●	●	Serpentine drive belt with automatic tensioner
▲	▲	Ether start aid (recommended below –1 deg. C [30 deg. F])
▲	▲	Block heater (recommended below –18 deg. C [0 deg. F])
▲	▲	Diesel-fired coolant heater (DFCH) (required below –25 deg. C [–13 deg. F])
●	●	Programmable auto-shutdown
●	●	Automatic turbo cool-down/shutdown timer
●	●	Flat-black exhaust stack
▲	▲	Chrome exhaust stack
▲	▲	Severe-duty fuel filter
▲	▲	Severe-duty fuel filter with heater
●	●	Electronic control with automatic engine protection
<b>Cooling</b>		
●	●	Dual hydraulically driven, side-mounted fans
●	●	Side-mounted radiators (2), charge-air cooler, front and mid-axle coolers, transmission cooler, hydraulic cooler, air-conditioner condenser, and fuel cooler
●	●	Integral engine oil cooler
●	●	Remote pressurized coolant reservoir
●	●	John Deere Cool-Gard™ II long-life engine coolant
●	●	Engine cooling rated –37 deg. C (–34 deg. F)
▲	▲	Automatic reversing cooling fans
<b>Powertrain</b>		
●	●	Transmission diagnostic ports
●	●	Transmission oil-temperature self-protection
●	●	Remote-mounted spin-on transmission oil filters
●	●	Remote-mounted replaceable-element axle-oil filters
●	●	Axle-oil temperature and lube-pressure sensing
●	●	Automatic engaging retarder with selectable aggressiveness

410E	460E	Powertrain (continued)
●	●	Normal, Traction, and Eco selectable drive modes
●	●	Automatic differential locks with manual override
<b>Electrical System</b>		
●	●	24-volt system voltage
●	●	145-amp alternator
●	●	Solid-state electrical distribution system
●	●	Battery disconnect
●	●	Batteries, 2 x 1,400 CCA
●	●	LED rear turn signals/brake lights
●	●	Lights, halogen drive, stair egress, and service lights
▲	▲	Premium 11-light LED package (6 forward, 2 rear cab, 2 rear-facing rear frame, and 1 stair egress)
●	●	Electric horn
●	●	Reverse alarm
▲	▲	Yellow beacon/strobe light
▲	▲	Green seat-belt indicator beacon
▲	▲	24-volt to 12-volt 15- or 25-amp converter
<b>Hydraulic System</b>		
●	●	Closed-center, load-sensing system
●	●	Axial-piston, variable-displacement main pump
●	●	Single-stage, dual-acting, dump-body tip cylinders
●	●	Electrohydraulic dump-body control
<b>Steering System</b>		
●	●	Ground-driven secondary steering pump
<b>Operator Station</b>		
●	●	ROPS/FOPS certification
●	●	Keyless start with multiple security codes
●	●	Tilt operator station for service access
●	●	Programmable dump-body control settings
●	●	Air conditioner
●	●	Heater
▲	▲	Automatic temperature control (ATC) system
●	●	AM/FM/ Weather-Band (WB) radio
▲	▲	Premium radio with AM/FM/WB/USB/Bluetooth® streaming and hands free
●	●	Rear window guard
●	●	Wiper/washer with intermittent control
▲	▲	Rear wiper
●	●	Tilt and telescoping steering wheel
●	●	Cloth seat with fore/aft isolation and heavy-duty suspension
▲	▲	Premium leather/cloth, heated/ventilated seat with fore/aft isolation and heavy-duty suspension
●	●	Orange 76-mm (3 in.) retractable operator seat belt
●	●	Foldaway trainer seat with retractable seat belt

410E	460E	Operator Station (continued)
▲	▲	Orange retractable 4-point harness
●	●	12-volt power outlets (2)
●	●	Cup holder
●	●	Rearview camera with designated display
▲	▲	Electric adjustable and heated mirrors
●	●	Deluxe 178-mm (7 in.) color LCD monitor: Speedometer / Fuel gauge / Transmission oil temperature gauge / Engine coolant temperature gauge / Gear indicator / Tachometer / Battery voltage / Hour meter / Odometer / Fuel consumption / Trip counter / Trip timer / Trip distance / Metric/Imperial units / Service codes/diagnostics / LED indicator lights and audible alarm / Programmable dump body rollover protection / Onboard weighing display / Multi-language capability / Tire-pressure-monitoring system warning
●	●	Backlit sealed-switch module functions: Keyless start/stop / F-N-R / Hazard light button / Park brake / Descent control / Gear-lock button / Gear up/down button / Inter-axle diff lock / Retarder adjustment / Automatic dump-body control settings / Drive modes / Retarder control
●	●	Dump-body lever control
<b>Dump Body</b>		
●	●	Bin-lock pin
▲	▲	Dump-body liner (steel)
▲	▲	Tailgate
▲	▲	Dump-body heater
▲	▲	Less dump body and cylinders
<b>Other</b>		
●	●	29.5R25 radial earthmovers
▲	▲	875/65R29 radial earthmovers
▲	▲	Fluid quick-service bank
●	●	Point-of-use grease
▲	▲	Banked manual grease
▲	▲	Auto-lube system with ground-level refill
●	●	Articulation lock
●	●	Fluid-sampling ports
●	●	Engine-compartment light with timer
▲	▲	Onboard weighing system with external load lights
●	●	Tire-pressure-monitoring system with temperature compensation
●	●	Fire extinguisher
▲	▲	Wheel chocks
●	●	JDLink™ wireless communication system with 5-year subscription (available in specific countries; see your dealer for details)
▲	▲	JDLink dual-mode cellular/satellite wireless communication system with 3-year subscription (available in specific countries; see your dealer for details)

While general information, pictures, and descriptions are provided, some illustrations and text may include product options and accessories NOT AVAILABLE in all regions, and in some countries products and accessories may require modifications or additions to ensure compliance with the local regulations of those countries.

Net engine power is with standard equipment including air cleaner, exhaust system, alternator, and cooling fan at test conditions specified per ISO 9249. Specifications and design subject to change without notice. Wherever applicable, specifications are in accordance with ISO standards. Except where otherwise noted, these specifications are based on units with standard equipment, ROPS cabs, 29.5R25 radial earthmover tires, full fuel tanks, and 79-kg (175 lb.) operators. Capacity and loaded weights are based on 1640-kg/m<sup>3</sup> (2,759 lb./cu. yd.) material.

